



THE BEAST HEAVY DUTY FLAP VALVE PUMP

The only AODD Flap Valve Pump designed to reliably handle packable dust, small solids, slurries, and large solids



**WARREN
RUPP, INC.**

THE BEAST HEAVY DUTY FLAP VALVE PUMP – FEATURES & BENEFITS

Multiple Material Options – Aluminum, Cast Iron, Stainless Steel, and Polypropylene

Thick, Robust Wetted Chambers for enhanced abrasion resistance

Top Suction / Bottom Discharge for easy passage of settling solids

All Bolted Construction for long term, leak free performance

ESADS+ Air Distribution System for enhanced reliability and speedy serviceability

Best-In-Class Efficiency – lowest air consumption in its class

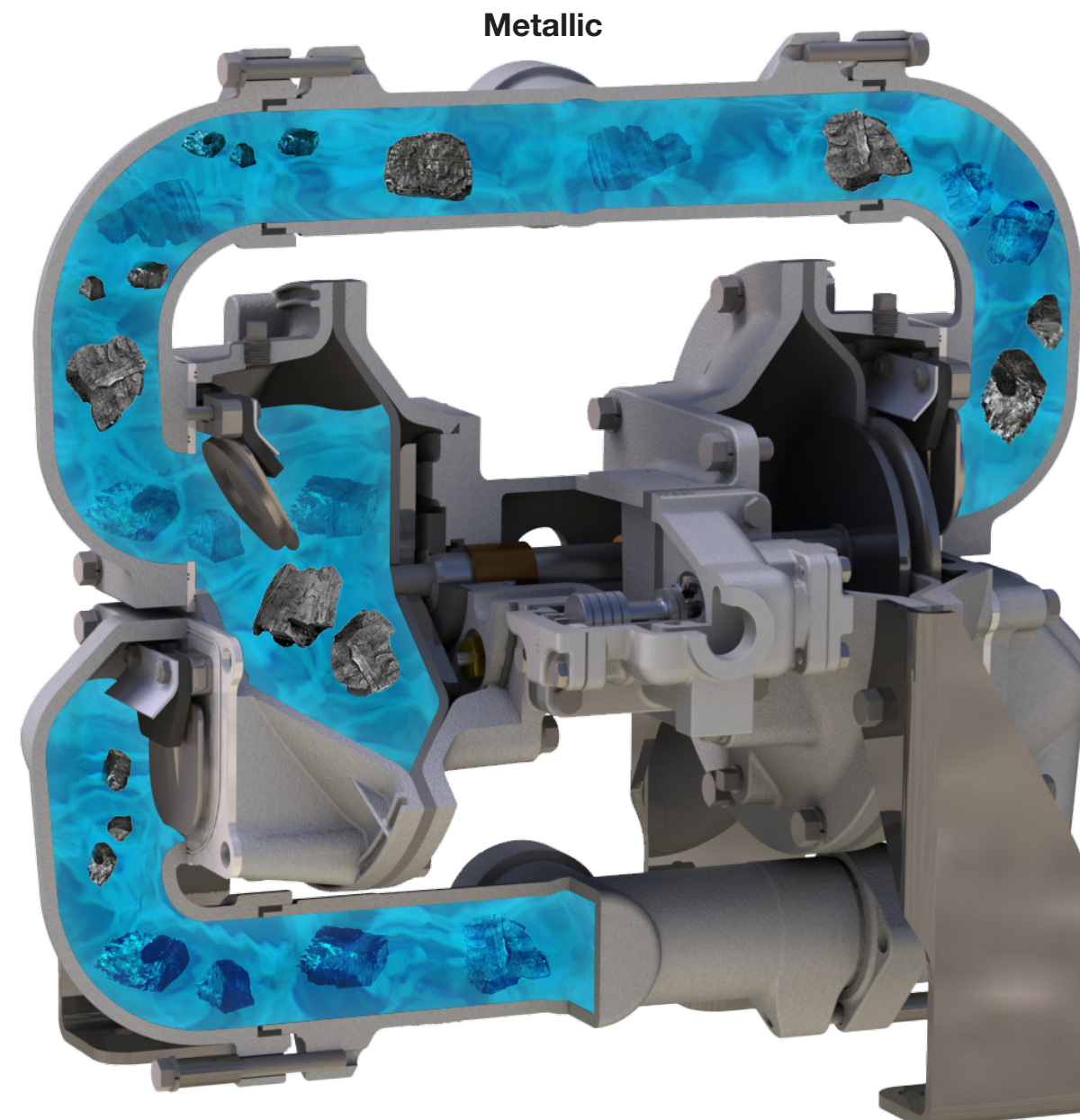
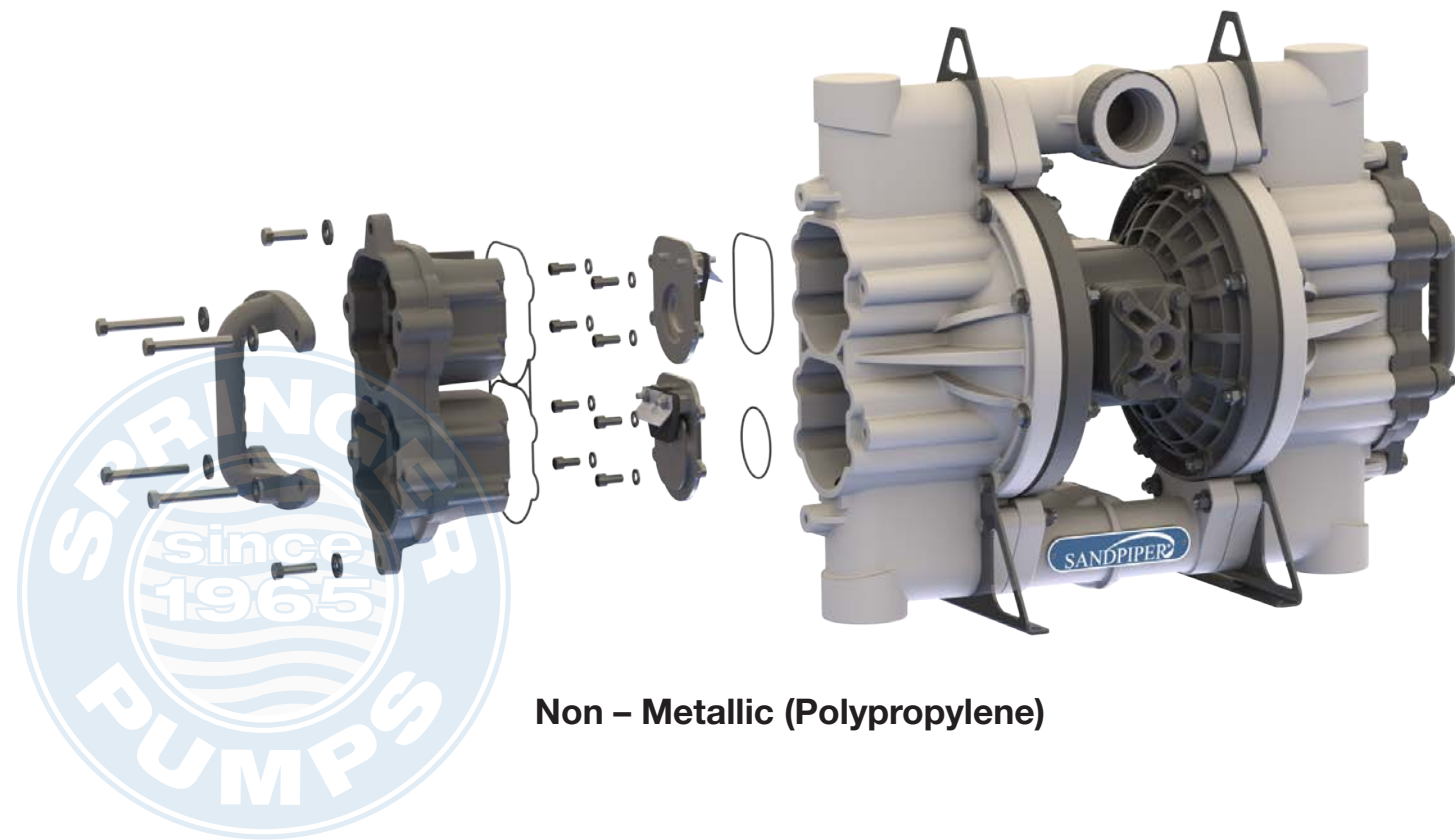

Additional Features Non-Metallic

Only 58 lbs (27 KG) for easy mobility and worker safety

Clean-Out Caps for fast, simple maintenance or inspection without pump disassembly

Ergonomic Handles that can be positioned either horizontally or vertically

Fluid Connection Options – either FNPT or ANSI/DIN flange

PATENT PENDING FLAP – FEATURES & BENEFITS

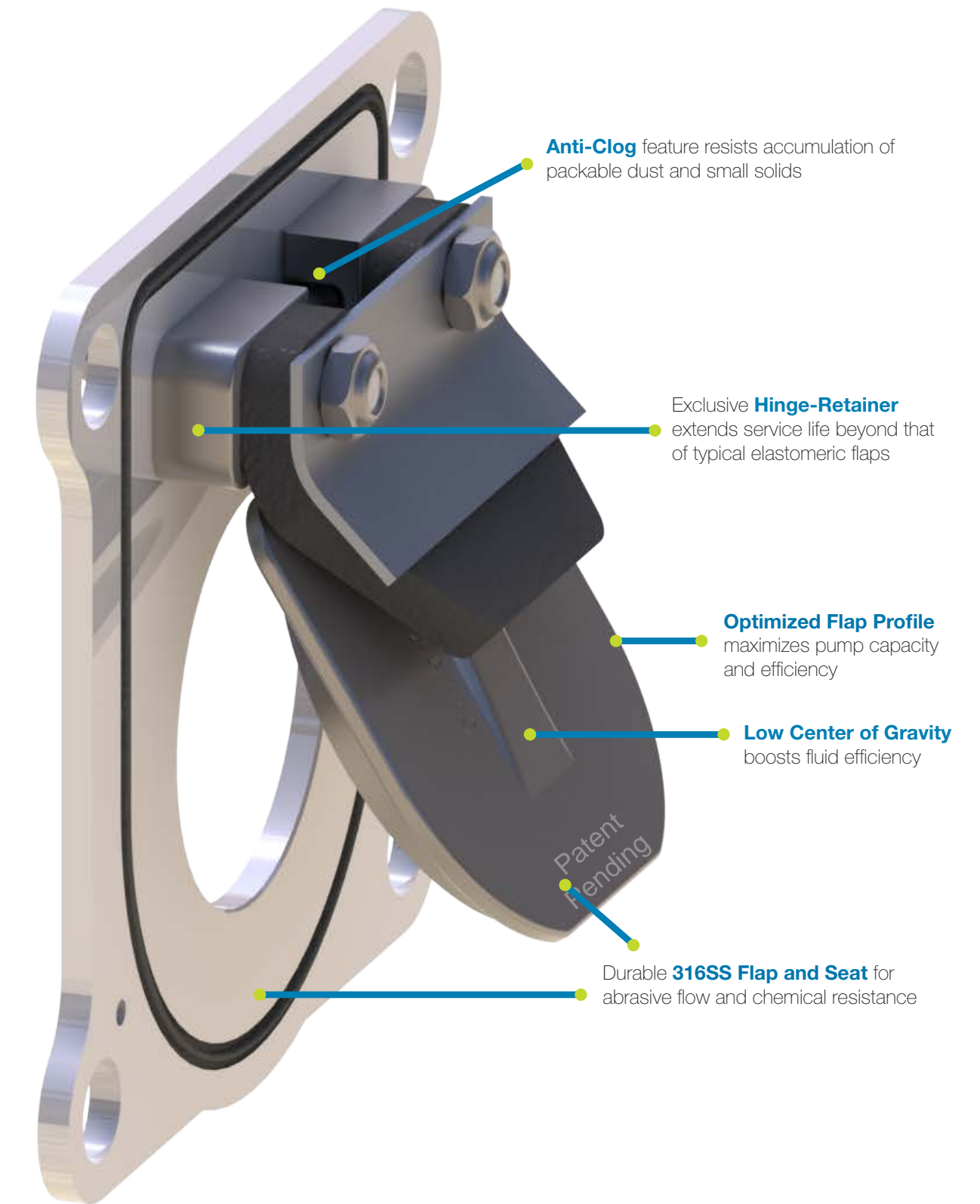

SPECIFICATIONS NON-METALLIC

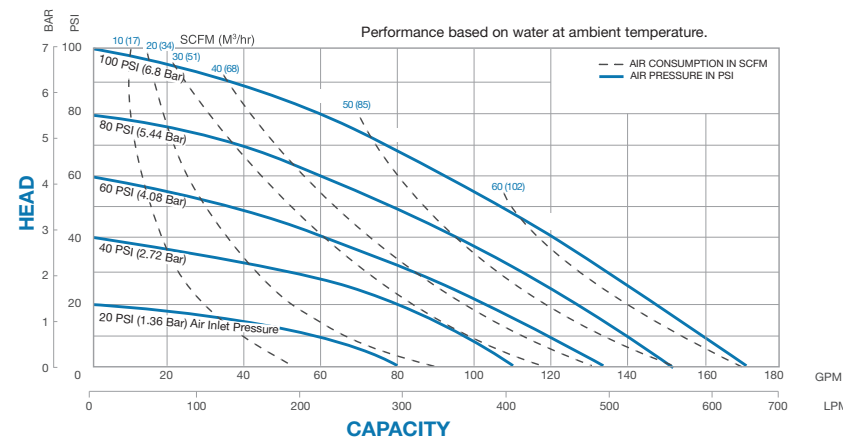

FLOW RATE
Adjustable to 0-170 gpm (0-644 lpm)

PORT SIZE
Inlet and Outlet 2" NPT or BSPT

MAXIMUM OPERATING PRESSURE
100 psi (7 bar)

DISPLACEMENT/STROKE
.50 Gallon / 1.9 liter

MAX. PARTICLE SIZE
Diameter 1.8" (45mm)

SHIPPING WEIGHT
Pump: 58 lbs. (27kg)
Shipping: 70 lbs. (31.7kg)

COMMON BEAST APPLICATIONS



Mine Dewatering

- Coal slurry transfer
- Mine face dewatering
- Roadway and drift water evacuation

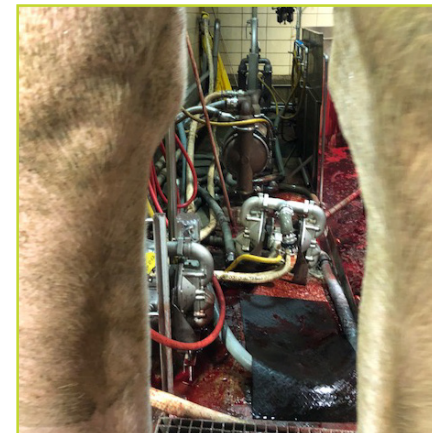

Meat & Poultry Processing

- Animal blood transfer
- Eviscerated animal parts transfer
- Wastewater sludge



Chemical Sumps

- Debris (leaves & needles, dirt, trash, ear plugs, etc....)
- Stray chemicals
- Variable fluid depths

SPECIFICATIONS METALLIC

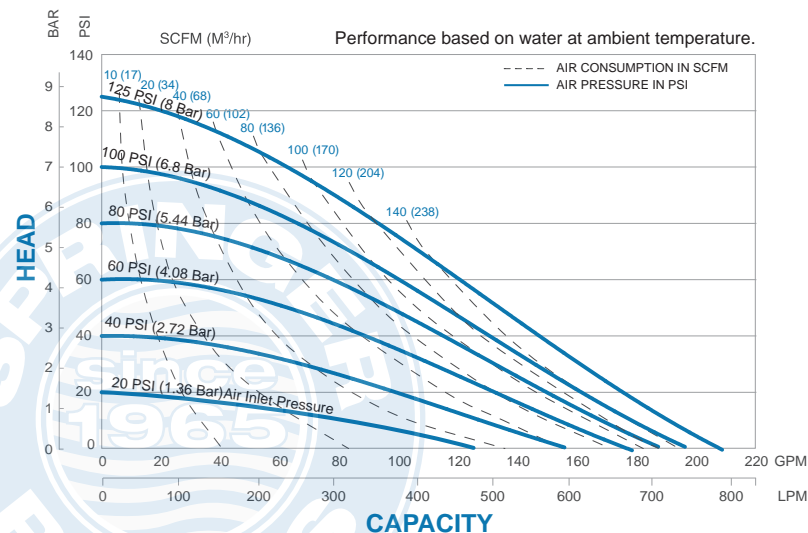

FLOW RATE
Adjustable to 0-208 gpm (0-787 lpm)

PORT SIZE
Inlet and Outlet 2" NPT or BSPT

MAXIMUM OPERATING PRESSURE
125 psi (8.6 bar)

DISPLACEMENT/STROKE
.50 Gallon / 1.9 liter

MAX. PARTICLE SIZE
Diameter 1.8" (45mm)

SHIPPING WEIGHT
Aluminum 88 lbs. (39.9kg)
Cast Iron 130 lbs. (59kg)
Stainless Steel 140 lbs. (63.5kg)

SANDPIPER®

Warren Rupp, Inc.
A Unit of IDEX Corporation
800 North Main Street
Mansfield, OH 44902 USA



Scan to learn more

Phone: 419.524.8388
Fax: 419.522.7867
SANDPIPERPUMP.COM



Visit www.sandpiperpump.com and click on "Find a distributor" to contact your local distributor to place your order

©Copyright 2022 Warren Rupp, Inc. All Rights Reserved.

SP_BEASTBrochure-rev0322