

SERVICE & OPERATING MANUAL

Original Instructions

1: PUMP SPECS

2: INSTAL & OP

3: EXP VIEW

4: AIR END

5: WET END

6: OPTIONAL

7: WARRANTY

Certified Quality



Member of
Hydraulic
INSTITUTE

EAC

Model S10

Non-Metallic Design Level 2

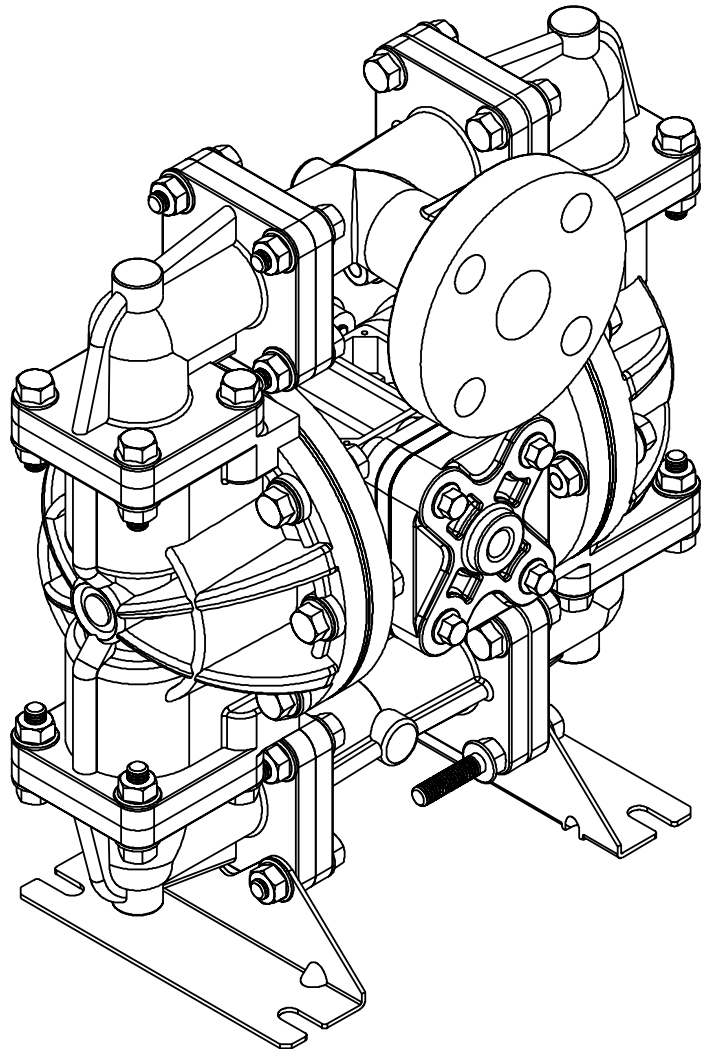

Warren Rupp, Inc.
A Unit of IDEX Corporation
800 N. Main St.,
Mansfield, Ohio 44902 USA
Telephone 419.524.8388
Fax 419.522.7867
SANDPIPERPUMP.COM

IDEX

© Copyright 2016 Warren Rupp, Inc.
All rights reserved

SANDPIPER®
A WARREN RUPP, INC. BRAND

SANDPIPERPUMP.COM

Tel: 866-777-6060
Fax: 866-777-6383

Springer Pumps, LLC

Website: www.springerpumps.com
Int'l: +001 267 404 2910

Safety Information

IMPORTANT



Read the safety warnings and instructions in this manual before pump installation and start-up. Failure to comply with the recommendations stated in this manual could damage the pump and void factory warranty.



When the pump is used for materials that tend to settle out or solidify, the pump should be flushed after each use to prevent damage. In freezing temperatures the pump should be completely drained between uses.

CAUTION



Before pump operation, inspect all fasteners for loosening caused by gasket creep. Retighten loose fasteners to prevent leakage. Follow recommended torques stated in this manual.



Nonmetallic pumps and plastic components are not UV stabilized. Ultraviolet radiation can damage these parts and negatively affect material properties. Do not expose to UV light for extended periods of time.



WARNING
Pump not designed, tested or certified to be powered by compressed natural gas. Powering the pump with natural gas will void the warranty.

WARNING



When used for toxic or aggressive fluids, the pump should always be flushed clean prior to disassembly.



Before maintenance or repair, shut off the compressed air line, bleed the pressure, and disconnect the air line from the pump. Be certain that approved eye protection and protective clothing are worn at all times. Failure to follow these recommendations may result in serious injury or death.



Airborne particles and loud noise hazards. Wear eye and ear protection.



In the event of diaphragm rupture, pumped material may enter the air end of the pump, and be discharged into the atmosphere. If pumping a product that is hazardous or toxic, the air exhaust must be piped to an appropriate area for safe containment.



Take action to prevent static sparking. Fire or explosion can result, especially when handling flammable liquids. The pump, piping, valves, containers and other miscellaneous equipment must be properly grounded.



This pump is pressurized internally with air pressure during operation. Make certain that all fasteners are in good condition and are reinstalled properly during reassembly.



Use safe practices when lifting

Grounding ATEX Pumps



ATEX compliant pumps are suitable for use in explosive atmospheres when the equipment is properly grounded in accordance with local electrical codes. Pumps equipped with electrically conductive diaphragms are suitable for the transfer of conductive or non-conductive fluids of any explosion group. When operating pumps equipped with non-conductive diaphragms that exceed the maximum permissible projected area, as defined in EN 13463-1: 2009 section 6.7.5 table 9, the following protection methods must be applied:

- Equipment is always used to transfer electrically conductive fluids or
- Explosive environment is prevented from entering the internal portions of the pump, i.e. dry running

For further guidance on ATEX applications, please consult the factory.

Table of Contents

SECTION 1: PUMP SPECIFICATIONS.....1

- Nomenclature
- Performance
- Materials
- Dimensional Drawings

SECTION 2: INSTALLATION & OPERATION.....4

- Principle of Pump Operation
- Typical Installation Guide
- Troubleshooting

SECTION 3: EXPLODED VIEW7

- Composite Drawings
- Parts List
- Materials Code

SECTION 4: AIR END.....10

- Air Distribution Valve Assembly
- Air Valve with Stroke Indicator Option
- Pilot Valve
- Intermediate Assembly

SECTION 5: WET END14

- Diaphragm Drawing
- Diaphragm Servicing

SECTION 6: OPTIONAL CONFIGURATIONS....16

- Solenoid Shifted Air Valve
- Dual Port

SECTION 7: WARRANTY & CERTIFICATES18

- Warranty
- CE Declaration of Conformity - Machinery
- ATEX Declaration of Conformity

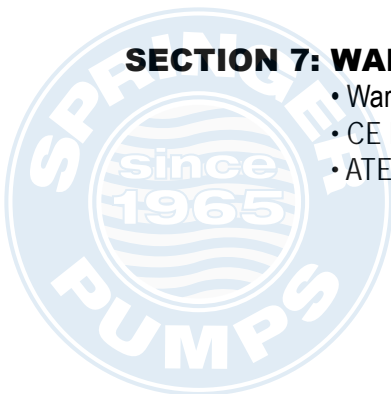

Explanation of Pump Nomenclature

1: PUMP SPECS

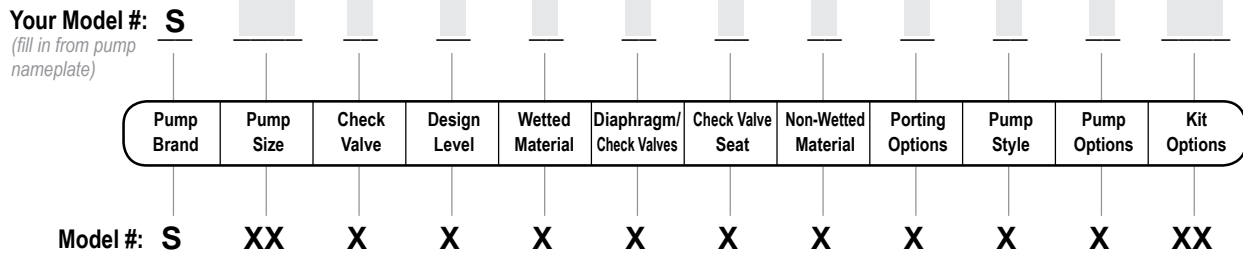

Pump Brand
S SANDPIPER®

Pump Size
10 1"

Check Valve Type
B Ball

Design Level
1 Design Level 1

Wetted Material
K PVDF
N Nylon
P Polypropylene

Diaphragm/Check Valve Materials
1 Santoprene/Santoprene
2 Virgin PTFE-Santoprene Backup/
Virgin PTFE
7 Santoprene/Nitrile
8 Virgin PTFE-Santoprene Backup/
FKM
Z One-Piece Bonded/PTFE

Check Valve Seat
K PVDF
N Nylon
P Polypropylene

Non-Wetted Material Options
P Polypropylene
I Polypropylene with PTFE Hardware

Porting Options
A ANSI Flange

Pump Style
S Standard

Pump Options
0 None
1 Sound Dampening Muffler
2 Mesh Muffler
6 Metal Muffler

Kit Options
00. None
P0. 10-30VDC Pulse Output Kit
P1. Intrinsically-Safe 5-30VDC, 110/120VAC,
220/240VAC
Pulse Output Kit

P2. 110/120 or 220/240VAC Pulse
Output Kit
E0. Solenoid Kit w/24VDC Coil
E1. Solenoid Kit 24VDC Explosion-Proof
Coil
E2. Solenoid Kit w/24VAC/12VDC Coil
E3. Solenoid Kit w/12VDC Explosion-
Proof Coil
E4. Solenoid Kit w/110VAC Coil
E5. Solenoid Kit w/110VAC 60 Hz
Explosion-Proof Coil
E6. Solenoid Kit w/220VAC Coil
E7. Solenoid Kit w/220VAC 60 Hz
Explosion-Proof Coil
E8. Solenoid Kit w/110VAC 50 Hz
Explosion-Proof Coil
E9. Solenoid Kit w/230VAC 50 Hz
Explosion-Proof Coil
SP Stroke Indicator Pins

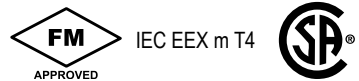

Note: Pump models equipped with these explosion-proof solenoid kit options E1, E3, E5, E7, E8 or E9, are certified and approved by the above agencies. They are NOT ATEX compliant.

Your Serial #: (fill in from pump nameplate) _____

Special Conditions For Safe Use: Conductive polypropylene, conductive acetal, or conductive PVDF pumps are not to be installed in applications where the pumps may be subjected to oil, greases and hydraulic liquids

ATEX Detail

(1) II 1G c T5
II 1D c T100°C
IM1 c
IM2 c
Models equipped with Wetted Options S or H,
Non-Wetted Option C, Pump Options 6 or 7, and Kit
Option 0.

(2) II 2G Ex ia c IIC T5
II 2D Ex c ia 20 IP67
T100°C

Note: Pumps ordered with the options listed in (1) to the left are ATEX compliant when ordered with kit option P1.

II 2G c T5
II 2D c T100°C
Models equipped with Wetted Options A,S or H,
Non-Wetted Options A or Y, Pump Options 6 or 7,
and Kit Option 0.

(3) II 2G EEx m c II T5
II 2D c IP65 T100°C

Note: Pumps ordered with the options listed in (1) to the left are ATEX compliant when ordered with kit option A1, A2, A3, or A4. Compressed Air Temperature Range: Maximum Ambient Temperature to plus 50°C.

(4) IEC EEX m T4

Note: Pump models equipped with these explosion-proof solenoid kit options E1, E3, E5, E7, E8 or E9, are certified and approved by the above agencies. They are NOT ATEX compliant.

Performance

S10 NON-METALLIC

SUCTION/DISCHARGE PORT SIZE

- 1" ANSI Flange

CAPACITY

- 0 to 23 gallons per minute
(0 to 87 liters per minute)

AIR DISTRIBUTION VALVE

- No-lube, no-stall design

SOLIDS-HANDLING

- Up to .15 in. (4mm)

HEADS UP TO

- 100 psi or 231 ft. of water
(7 bar or 70 meters)

DISPLACEMENT/STROKE

- .026 Gallon / .098 liter

MAXIMUM OPERATING PRESSURE

- 100 psi (6.8 bar)

SHIPPING WEIGHT

- 19 lbs. (9 kg)
- 23 lbs. (10 kg)
- 20 lbs. (9 kg)

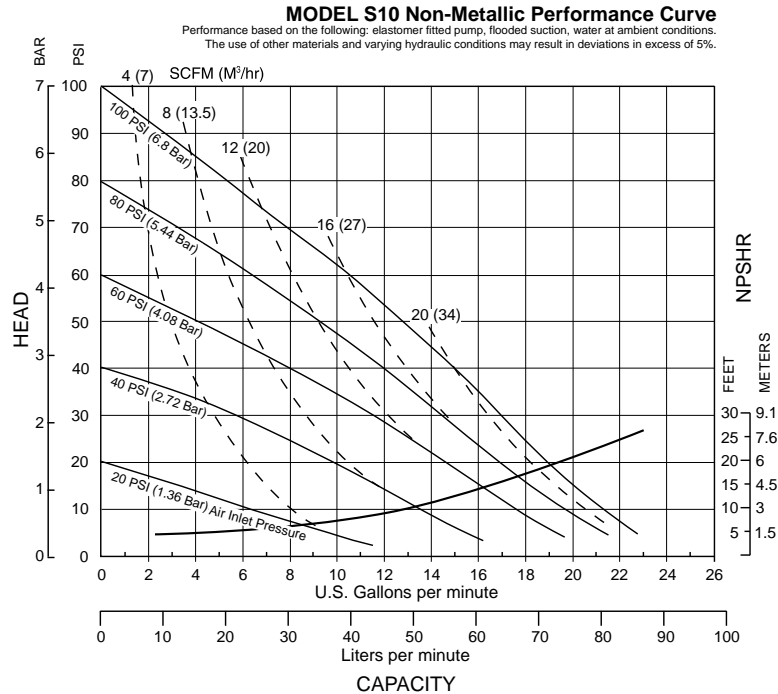

1: PUMP SPECS

Materials

Material Profile:	Operating Temperatures:	
	Max.	Min.
CAUTION! Operating temperature limitations are as follows:		
Conductive Acetal: Tough, impact resistant, ductile. Good abrasion resistance and low friction surface. Generally inert, with good chemical resistance except for strong acids and oxidizing agents.	190°F 88°C	-20°F -29°C
EPDM: Shows very good water and chemical resistance. Has poor resistance to oils and solvents, but is fair in ketones and alcohols.	280°F 138°C	-40°F -40°C
FKM: (Fluorocarbon) Shows good resistance to a wide range of oils and solvents; especially all aliphatic, aromatic and halogenated hydrocarbons, acids, animal and vegetable oils. Hot water or hot aqueous solutions (over 70°F) will attack FKM.	350°F 177°C	-40°F -40°C
Hytrel®: Good on acids, bases, amines and glycols at room temperatures only.	220°F 104°C	-20°F -29°C
Neoprene: All purpose. Resistance to vegetable oils. Generally not affected by moderate chemicals, fats, greases and many oils and solvents. Generally attacked by strong oxidizing acids, ketones, esters and nitro hydrocarbons and chlorinated aromatic hydrocarbons.	200°F 93°C	-10°F -23°C
Nitrile: General purpose, oil-resistant. Shows good solvent, oil, water and hydraulic fluid resistance. Should not be used with highly polar solvents like acetone and MEK, ozone, chlorinated hydrocarbons and nitro hydrocarbons.	190°F 88°C	-10°F -23°C
Nylon: 6/6 High strength and toughness over a wide temperature range. Moderate to good resistance to fuels, oils and chemicals.	180°F 82°C	32°F 0°C

Polypropylene: A thermoplastic polymer. Moderate tensile and flex strength. Resists strong acids and alkali. Attacked by chlorine, fuming nitric acid and other strong oxidizing agents.	180°F 82°C	32°F 0°C
PVDF: (Polyvinylidene Fluoride) A durable fluoroplastic with excellent chemical resistance. Excellent for UV applications. High tensile strength and impact resistance.	250°F 121°C	0°F -18°C
Santoprene®: Injection molded thermoplastic elastomer with no fabric layer. Long mechanical flex life. Excellent abrasion resistance.	275°F 135°C	-40°F -40°C
UHMW PE: A thermoplastic that is highly resistant to a broad range of chemicals. Exhibits outstanding abrasion and impact resistance, along with environmental stress-cracking resistance.	180°F 82°C	-35°F -37°C
Urethane: Shows good resistance to abrasives. Has poor resistance to most solvents and oils.	150°F 66°C	32°F 0°C
Virgin PTFE: (PFA/TFE) Chemically inert, virtually impervious. Very few chemicals are known to chemically react with PTFE; molten alkali metals, turbulent liquid or gaseous fluorine and a few fluoro-chemicals such as chlorine trifluoride or oxygen difluoride which readily liberate free fluorine at elevated temperatures.	220°F 104°C	-35°F -37°C
<i>Maximum and Minimum Temperatures are the limits for which these materials can be operated. Temperatures coupled with pressure affect the longevity of diaphragm pump components. Maximum life should not be expected at the extreme limits of the temperature ranges.</i>		
Metals:		
Alloy C: Equal to ASTM494 CW-12M-1 specification for nickel and nickel alloy.		
Stainless Steel: Equal to or exceeding ASTM specification A743 CF-8M for corrosion resistant iron chromium, iron chromium nickel and nickel based alloy castings for general applications. Commonly referred to as 316 Stainless Steel in the pump industry.		

Ambient temperature range -20 C to +40 C
 Process temperature range -20 C to +80 C for models rated as category 1 equipment
 -20 C to +100 C for model rated as category 2 equipment

For specific applications, always consult the Chemical Resistance Chart.

In addition, the ambient temperature range and the process temperature range do not exceed the operating temperature range of the applied non-metallic parts as listed in the manuals of the pumps.



SANDPIPERPUMP.COM

Model S10 Non-Metallic • 2

Tel: 866-777-6060
 Fax: 866-777-6383

Springer Pumps, LLC

Website: www.springerpumps.com
 Int'l: +001 267 404 2910

s10nmdl1smsm-rev1117

S10 Non-Metallic

Dimensions in inches (metric dimensions in brackets). Dimensional Tolerance .125" (3mm).

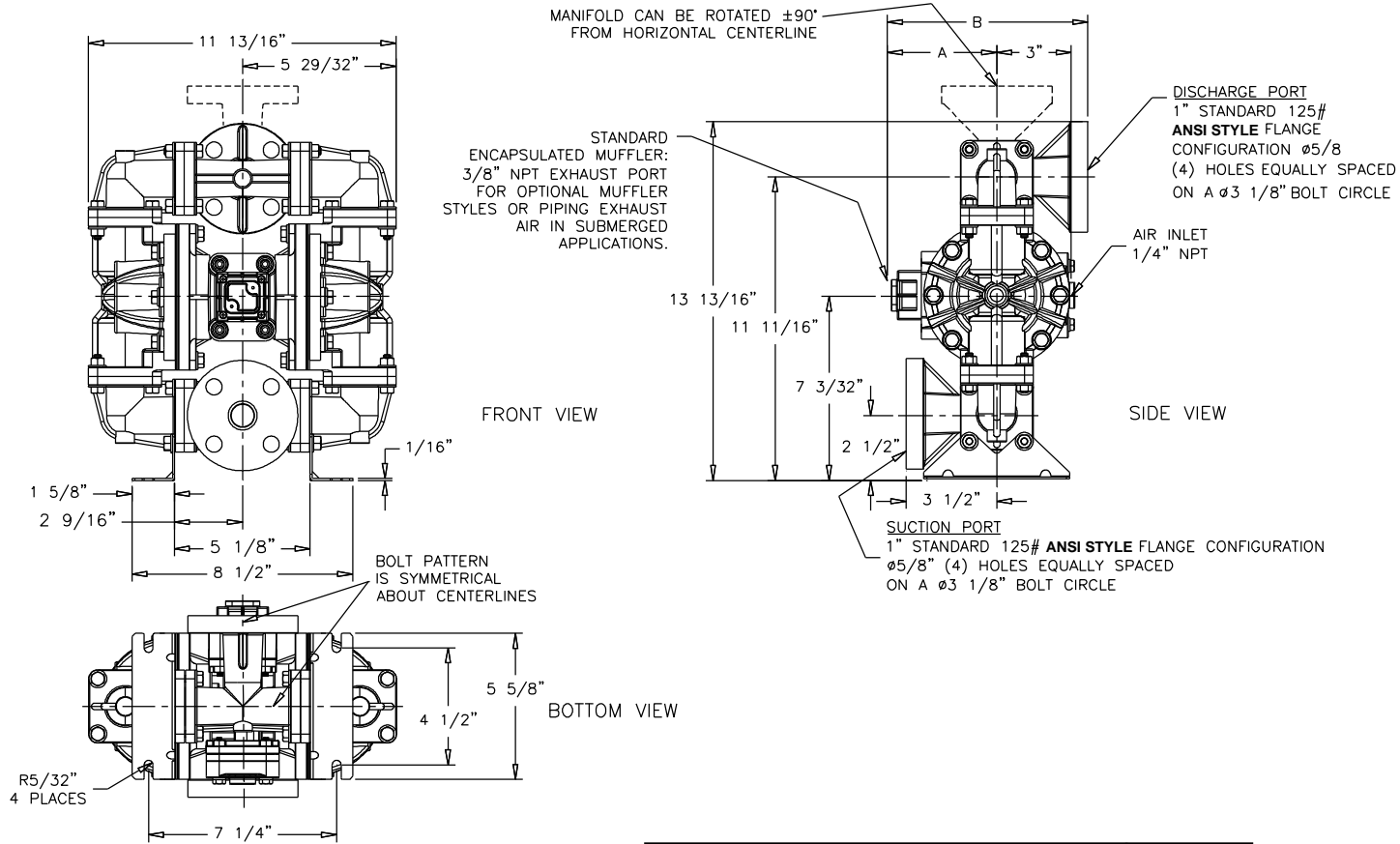

Dimension	A	B
Standard Pump	4 1/16"	7 9/16"
Pulse Output Kit	4 1/16"	9 5/16"
Mesh Muffler	5 3/4"	9 1/4"



S10 Non-Metallic

Dimensions in inches (metric dimensions in brackets). Dimensional Tolerance .125" (3mm).

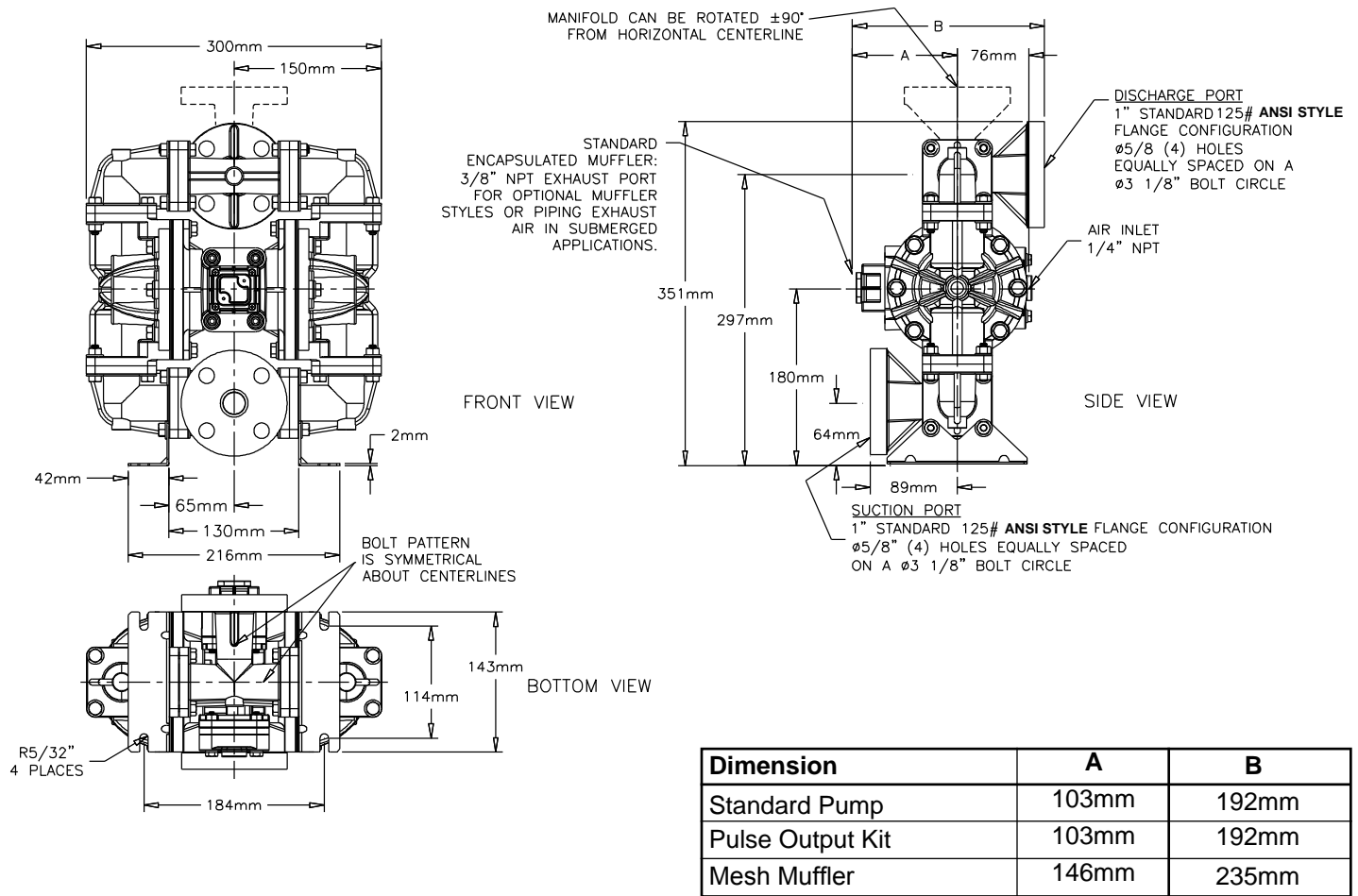

Principle of Pump Operation

2: INSTAL & OP

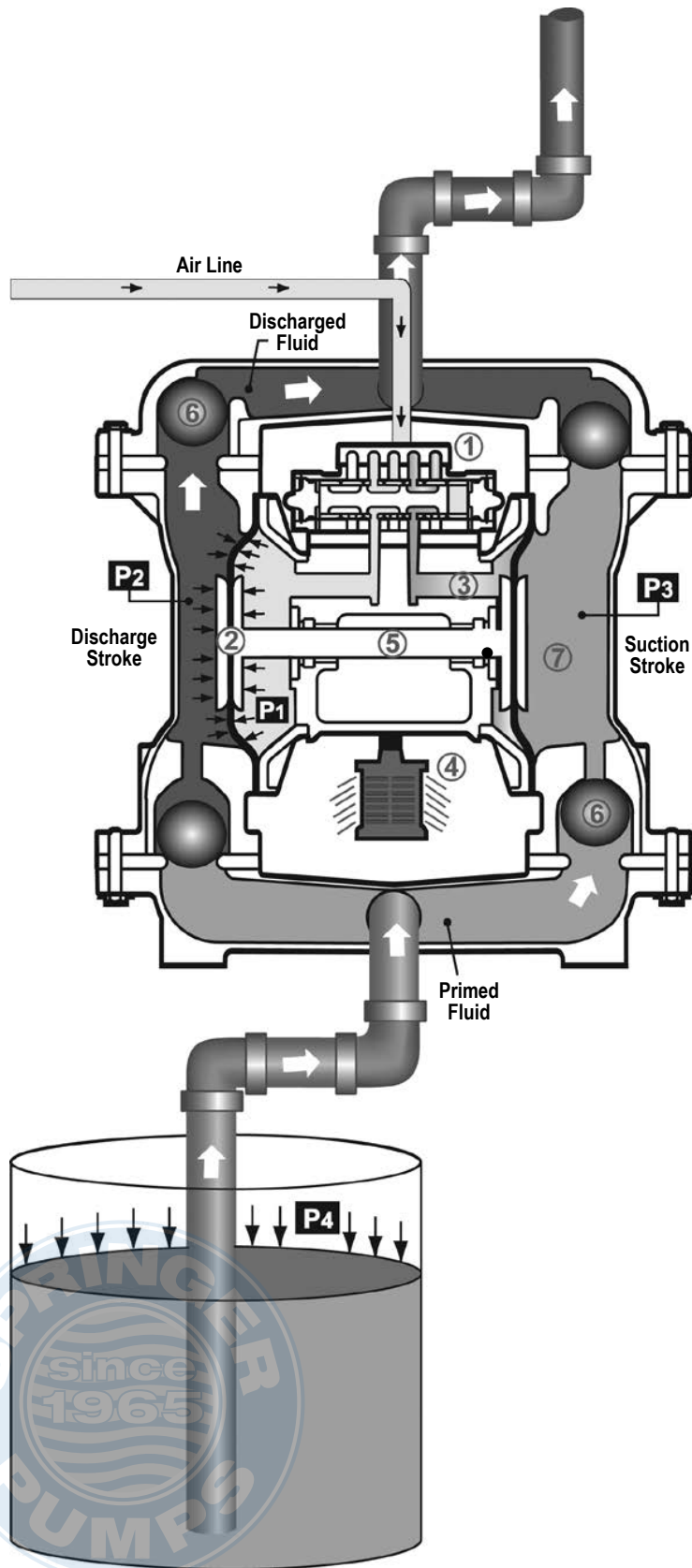

Air-Operated Double Diaphragm (AODD) pumps are powered by compressed air or nitrogen.

The main directional (air) control valve ① distributes compressed air to an air chamber, exerting uniform pressure over the inner surface of the diaphragm ②. At the same time, the exhausting air ③ from behind the opposite diaphragm is directed through the air valve assembly(s) to an exhaust port ④.

As inner chamber pressure (P1) exceeds liquid chamber pressure (P2), the rod ⑤ connected diaphragms shift together creating discharge on one side and suction on the opposite side. The discharged and primed liquid's directions are controlled by the check valves (ball or flap) ⑥ orientation.

The pump primes as a result of the suction stroke. The suction stroke lowers the chamber pressure (P3) increasing the chamber volume. This results in a pressure differential necessary for atmospheric pressure (P4) to push the fluid through the suction piping and across the suction side check valve and into the outer fluid chamber ⑦.

Suction (side) stroking also initiates the reciprocating (shifting, stroking or cycling) action of the pump. The suction diaphragm's movement is mechanically pulled through its stroke. The diaphragm's inner plate makes contact with an actuator plunger aligned to shift the pilot signaling valve. Once actuated, the pilot valve sends a pressure signal to the opposite end of the main directional air valve, redirecting the compressed air to the opposite inner chamber.

SUBMERGED ILLUSTRATION

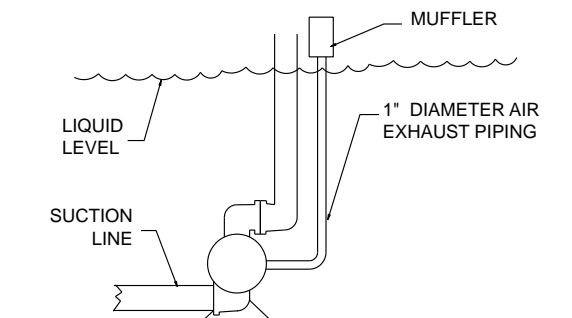

Pump can be submerged if the pump materials of construction are compatible with the liquid being pumped. The air exhaust must be piped above the liquid level. When the pumped product source is at a higher level than the pump (flooded suction condition), pipe the exhaust higher than the product source to prevent siphoning spills.

Recommended Installation Guide

Available Accessories:

1. Surge Suppressor
2. Filter/Regulator
3. Air Dryer

Note: Surge Suppressor and Piping must be supported after the flexible connection.

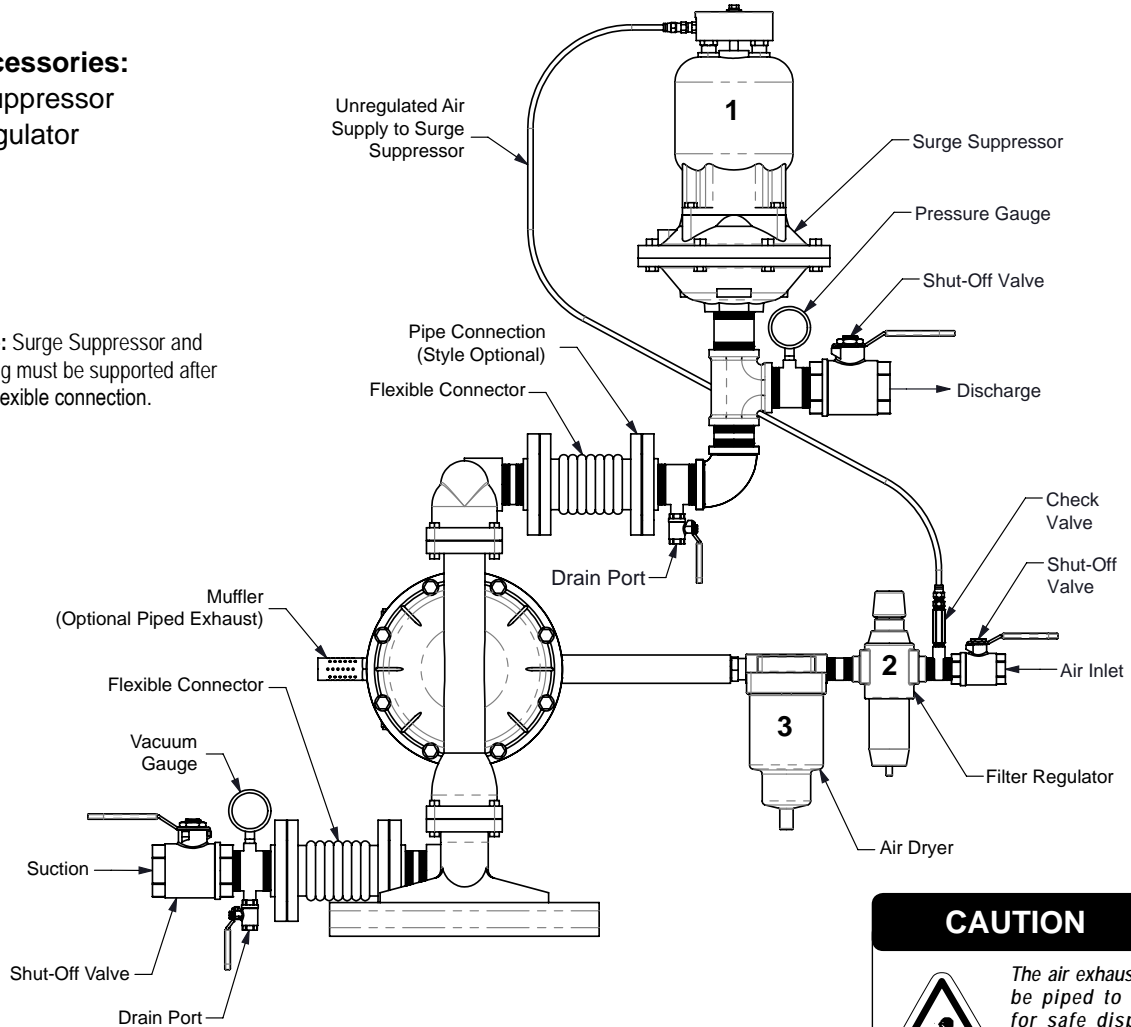

CAUTION

The air exhaust should be piped to an area for safe disposition of the product being pumped, in the event of a diaphragm failure.

Installation And Start-Up

Locate the pump as close to the product being pumped as possible. Keep the suction line length and number of fittings to a minimum. Do not reduce the suction line diameter.

Air Supply

Connect the pump air inlet to an air supply with sufficient capacity and pressure to achieve desired performance. A pressure regulating valve should be installed to insure air supply pressure does not exceed recommended limits.

Air Valve Lubrication

The air distribution system is designed to operate WITHOUT lubrication. This is the standard mode of operation. If lubrication is desired, install an air line lubricator set to deliver one drop of SAE 10 non-detergent oil for every 20 SCFM (9.4 liters/sec.) of air the pump consumes. Consult the Performance Curve to determine air consumption.

Air Line Moisture

Water in the compressed air supply may cause icing or freezing of the exhaust air, causing the pump to cycle erratically or stop operating. Water in the air supply can be reduced by using a point-of-use air dryer.

Air Inlet And Priming

To start the pump, slightly open the air shut-off valve. After the pump primes, the air valve can be opened to increase air flow as desired. If opening the valve increases cycling rate, but does not increase the rate of flow, cavitation has occurred. The valve should be closed slightly to obtain the most efficient air flow to pump flow ratio.

Troubleshooting Guide

2: INSTAL & OP

Symptom:	Potential Cause(s):	Recommendation(s):
Pump Cycles Once	Deadhead (system pressure meets or exceeds air supply pressure).	Increase the inlet air pressure to the pump. Pump is designed for 1:1 pressure ratio at zero flow. (Does not apply to high pressure 2:1 units).
	Air valve or intermediate gaskets installed incorrectly.	Install gaskets with holes properly aligned.
	Bent or missing actuator plunger.	Remove pilot valve and inspect actuator plungers.
Pump Will Not Operate / Cycle	Pump is over lubricated.	Set lubricator on lowest possible setting or remove. Units are designed for lube free operation.
	Lack of air (line size, PSI, CFM).	Check the air line size and length, compressor capacity (HP vs. CFM required).
	Check air distribution system.	Disassemble and inspect main air distribution valve, pilot valve and pilot valve actuators.
	Discharge line is blocked or clogged manifolds.	Check for inadvertently closed discharge line valves. Clean discharge manifolds/piping.
	Deadhead (system pressure meets or exceeds air supply pressure).	Increase the inlet air pressure to the pump. Pump is designed for 1:1 pressure ratio at zero flow. (Does not apply to high pressure 2:1 units).
	Blocked air exhaust muffler.	Remove muffler screen, clean or de-ice, and re-install.
	Pumped fluid in air exhaust muffler.	Disassemble pump chambers. Inspect for diaphragm rupture or loose diaphragm plate assembly.
Pump Cycles and Will Not Prime or No Flow	Pump chamber is blocked.	Disassemble and inspect wetted chambers. Remove or flush any obstructions.
	Cavitation on suction side.	Check suction condition (move pump closer to product).
	Check valve obstructed. Valve ball(s) not seating properly or sticking.	Disassemble the wet end of the pump and manually dislodge obstruction in the check valve pocket. Clean out around valve ball cage and valve seat area. Replace valve ball or valve seat if damaged. Use heavier valve ball material.
	Valve ball(s) missing (pushed into chamber or manifold).	Worn valve ball or valve seat. Worn fingers in valve ball cage (replace part). Check Chemical Resistance Guide for compatibility.
	Valve ball(s)/seat(s) damaged or attacked by product.	Check Chemical Resistance Guide for compatibility.
	Check valve and/or seat is worn or needs adjusting.	Inspect check valves and seats for wear and proper setting. Replace if necessary.
	Suction line is blocked.	Remove or flush obstruction. Check and clear all suction screens or strainers.
	Excessive suction lift.	For lifts exceeding 20' of liquid, filling the chambers with liquid will prime the pump in most cases.
	Suction side air leakage or air in product.	Visually inspect all suction-side gaskets and pipe connections.
	Pumped fluid in air exhaust muffler.	Disassemble pump chambers. Inspect for diaphragm rupture or loose diaphragm plate assembly.
Pump Cycles Running Sluggish/Stalling, Flow Unsatisfactory	Over lubrication.	Set lubricator on lowest possible setting or remove. Units are designed for lube free operation.
	Icing.	Remove muffler screen, de-ice, and re-install. Install a point of use air drier.
	Clogged manifolds.	Clean manifolds to allow proper air flow
	Deadhead (system pressure meets or exceeds air supply pressure).	Increase the inlet air pressure to the pump. Pump is designed for 1:1 pressure ratio at zero flow. (Does not apply to high pressure 2:1 units).
	Cavitation on suction side.	Check suction (move pump closer to product).
	Lack of air (line size, PSI, CFM).	Check the air line size, length, compressor capacity.
	Excessive suction lift.	For lifts exceeding 20' of liquid, filling the chambers with liquid will prime the pump in most cases.
	Air supply pressure or volume exceeds system hd.	Decrease inlet air (press. and vol.) to the pump. Pump is cavitating the fluid by fast cycling.
	Undersized suction line.	Meet or exceed pump connections.
	Restrictive or undersized air line.	Install a larger air line and connection.
	Suction side air leakage or air in product.	Visually inspect all suction-side gaskets and pipe connections.
	Suction line is blocked.	Remove or flush obstruction. Check and clear all suction screens or strainers.
	Pumped fluid in air exhaust muffler.	Disassemble pump chambers. Inspect for diaphragm rupture or loose diaphragm plate assembly.
	Check valve obstructed.	Disassemble the wet end of the pump and manually dislodge obstruction in the check valve pocket.
Product Leaking Through Exhaust	Check valve and/or seat is worn or needs adjusting.	Inspect check valves and seats for wear and proper setting. Replace if necessary.
	Entrained air or vapor lock in chamber(s).	Purge chambers through tapped chamber vent plugs. Purging the chambers of air can be dangerous.
Premature Diaphragm Failure	Diaphragm failure, or diaphragm plates loose.	Replace diaphragms, check for damage and ensure diaphragm plates are tight.
	Diaphragm stretched around center hole or bolt holes.	Check for excessive inlet pressure or air pressure. Consult Chemical Resistance Chart for compatibility with products, cleaners, temperature limitations and lubrication.
Unbalanced Cycling	Cavitation.	Enlarge pipe diameter on suction side of pump.
	Excessive flooded suction pressure.	Move pump closer to product. Raise pump/place pump on top of tank to reduce inlet pressure. Install Back pressure device (Tech bulletin 41r). Add accumulation tank or pulsation dampener.
	Misapplication (chemical/physical incompatibility).	Consult Chemical Resistance Chart for compatibility with products, cleaners, temperature limitations and lubrication.
Unbalanced Cycling	Incorrect diaphragm plates or plates on backwards, installed incorrectly or worn.	Check Operating Manual to check for correct part and installation. Ensure outer plates have not been worn to a sharp edge.
	Excessive suction lift.	For lifts exceeding 20' of liquid, filling the chambers with liquid will prime the pump in most cases.
	Undersized suction line.	Meet or exceed pump connections.
	Pumped fluid in air exhaust muffler.	Disassemble pump chambers. Inspect for diaphragm rupture or loose diaphragm plate assembly.
	Suction side air leakage or air in product.	Visually inspect all suction-side gaskets and pipe connections.
	Check valve obstructed.	Disassemble the wet end of the pump and manually dislodge obstruction in the check valve pocket.
	Check valve and/or seat is worn or needs adjusting.	Inspect check valves and seats for wear and proper setting. Replace if necessary.
Entrained air or vapor lock in chamber(s).	Purge chambers through tapped chamber vent plugs.	

For additional troubleshooting tips contact After Sales Support at service.warrenrupp@idexcorp.com or 419-524-8388

Composite Repair Parts Drawing

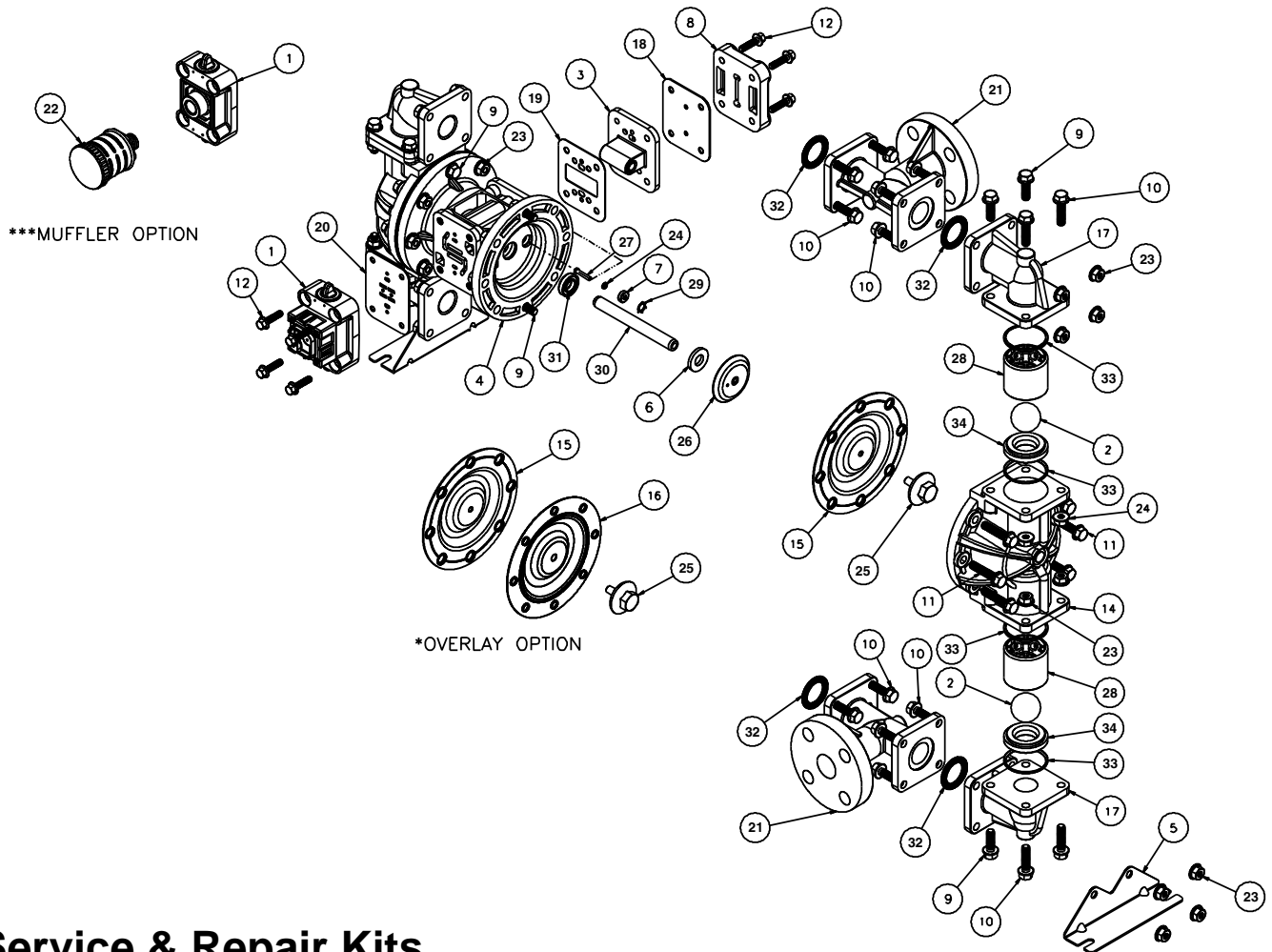

3: EXP VIEW

Service & Repair Kits

- 476-219-000 AIR END KIT**
Seals, O-rings, Gaskets, Bumpers, Retaining Rings, Air Valve Assembly and Pilot Valve Assembly.
- 476-220-000 AIR END KIT** for pumps equipped with Stroke Indicator (same components as above, except Valve Assembly with pins replaces Standard Air Valve).
- 476-166-354 WETTED END KIT**
Santoprene Diaphragms, Santoprene Check Balls and TFE Seals.
- 476-166-650 WETTED END KIT**
One-Piece Bond Diaphragm, PTFE Check Balls and PTFE Seals.
- 476-166-654 WETTED END KIT**
Santoprene Diaphragms, TFE Overlay Diaphragm, TFE Check Balls and TFE Seals.

****Note: Pumps equipped with these components are not ATEX compliant.**



SANDPIPER®
A WARREN RUPP, INC. BRAND

SANDPIPERPUMP.COM

s10nmdl1smsm-rev1117

Model S10 Non-Metallic • 8

Tel: 866-777-6060
Fax: 866-777-6383

Springer Pumps, LLC

Website: www.springerpumps.com
Int'l: +001 267 404 2910

Composite Repair Parts List

ITEM	PART NUMBER	DESCRIPTION	QTY
1	031-166-000	Air Valve Assembly (Integral Muffler)	1
	031-166-002	Air Valve Assembly (with PTFE Coated Hardware)	1
	031-167-000	Air Valve Assembly (with stroke Indicator Pins)	1
	031-167-002	Air Valve Assembly (with Stroke Indicator Pins and PTFE Coated Hardware)	1
	031-168-000	Air Valve Assembly (Optional Mufflers)	1
	031-168-000	Air Valve Assembly (Stroke Indicator & Optional Mufflers)	1
	031-176-000	Air Valve (High Temperature)	1
	031-177-000	Air Valve (High Temperature With Mufflers)	1
2	050-028-354	Ball, Check Valve	4
	050-028-600	Ball, Check Valve	4
3	095-091-000	Pilot Valve Assembly	1
	095-091-558	Pilot Valve Assembly (Conductive Acetal)	1
4	114-023-551	Bracket, Intermediate	1
5	115-142-115	Bracket, Mounting	2
6	132-034-360	Bumper, Diaphragm	2
7	135-036-506	Bushing, Plunger	2
8	165-110-551	Cap, Air Inlet	1
9	171-062-115	Capscrew, Flanged 5/16-18 x 1.00	8
	171-062-308	Capscrew, Flanged 5/16-18 x 1.00	8
	171-075-115	Capscrew, Flanged 5/16-18x 1.00	4
10	171-063-115	Capscrew, Flanged 5/16-18 x 1.25	24
	171-063-308	Capscrew, Flanged 5/16-18 x 1.25	24
11	171-064-115	Capscrew, Flanged 5/16-18 x 1.50	12
	171-064-308	Capscrew, Flanged 5/16-18 x 1.50	12
12	171-066-115	Capscrew, Flanged 1/4-20 x 1.25	8
	171-066-308	Capscrew, Flanged 1/4-20 x 1.25	8
14	196-162-520	Chamber, Outer	2
	196-162-542	Chamber, Outer	2
	196-162-552	Chamber, Outer	2
15	286-095-354	Diaphragm	2
	286-116-000	Diaphragm, One-Piece Bonded	2
16	286-096-600	Diaphragm, Overlay	2
17	312-107-520	Elbow	4
	312-107-542	Elbow	4
	312-107-552	Elbow	4
18	360-100-360	Gasket, Air Inlet	1
	360-100-379	Gasket, Air Inlet (Solenoid Option Only)	1
19	360-101-379	Gasket, Pilot Valve	1
20	360-102-360	Gasket, Air Valve	1
21	518-140-520	Manifold (ANSI)	2
	518-140-542	Manifold (ANSI)	2
	518-140-552	Manifold (ANSI)	2
22	530-023-600	Muffler	1
	530-024-000	Muffler	1
23	544-005-115	Nut, Flanged 5/16-18	36
	544-005-308	Nut, Flanged 5/16-18	36
24	560-001-360	O-ring	2
25	612-091-520	Plate, Outer Diaphragm	2
	612-091-542	Plate, Outer Diaphragm	2
	612-091-552	Plate, Outer Diaphragm	2
26	612-177-330	Plate, Inner Diaphragm	2
	612-221-330	Plate, Inner Diaphragm (use with One-Piece Bonded Diaphragm only)	2
27	620-019-115	Plunger, Actuator	2
28	670-050-520	Retainer, Ball	4
	670-050-542	Retainer, Ball	4
	670-050-552	Retainer, Ball	4
29	675-042-115	Ring, Retaining	2
30	685-056-120	Rod, Diaphragm	1
31	720-012-375	Seal, Diaphragm Rod	2
32	720-046-600	Seal, Manifold	4
33	720-051-600	Seal, Check Valve Retainer	8
34	722-081-520	Seat, Check Valve	4
	722-081-542	Seat, Check Valve	4
	722-081-552	Seat, Check Valve	4

NOT SHOWN:

535-069-000 Nameplate

3: EXP VIEW

MATERIAL CODES - THE LAST 3 DIGITS OF PART NUMBER

000	Assembly, sub-assembly; and some purchased items	364	E.P.D.M. Rubber Color coded: BLUE	PTFE Overlay, Balls, and Seals
010	Cast Iron	365	Neoprene Rubber Color coded: GREEN	668 PTFE, FDA Santoprene®/PTFE Delrin and Hytrel are registered tradenames of E.I. DuPont.
015	Ductile Iron	366	Food Grade Nitrile	Nylatron is a registered tradename of Polymer Corp.
020	Ferritic Malleable Iron	368	Food Grade EPDM	Gylon is a registered tradename of Garlock, Inc.
080	Carbon Steel, AISI B-1112	371	Philthane (Tuftane)	Santoprene is a registered tradename of Exxon Mobil Corp.
110	Alloy Type 316 Stainless Steel	374	Carboxylated Nitrile	Rulon II is a registered tradename of Dixon Industries Corp.
111	Alloy Type 316 Stainless Steel (Electro Polished)	375	Fluorinated Nitrile	Ryton is a registered tradename of Phillips Chemical Co.
112	Alloy C	378	High Density Polypropylene	Valox is a registered tradename of General Electric Co.
113	Alloy Type 316 Stainless Steel (Hand Polished)	379	Conductive Nitrile	
114	303 Stainless Steel	408	Cork and Neoprene	
115	302/304 Stainless Steel	425	Compressed Fibre	
117	440-C Stainless Steel (Martensitic)	426	Blue Gard	
120	416 Stainless Steel (Wrought Martensitic)	440	Vegetable Fibre	
148	Hardcoat Anodized Aluminum	500	Delrin® 500	
150	6061-T6 Aluminum	502	Conductive Acetal, ESD-800	
152	2024-T4 Aluminum (2023-T351)	503	Conductive Acetal, Glass-Filled	
155	356-T6 Aluminum	506	Delrin® 150	
156	356-T6 Aluminum	520	Injection Molded PVDF Natural color	
157	Die Cast Aluminum Alloy #380	540	Nylon	
158	Aluminum Alloy SR-319	542	Nylon	
162	Brass, Yellow, Screw Machine Stock	544	Nylon Injection Molded	
165	Cast Bronze, 85-5-5-5	550	Polyethylene	
166	Bronze, SAE 660	551	Glass Filled Polypropylene	
170	Bronze, Bearing Type, Oil Impregnated	552	Unfilled Polypropylene	
180	Copper Alloy	555	Polyvinyl Chloride	
305	Carbon Steel, Black Epoxy Coated	556	Black Vinyl	
306	Carbon Steel, Black PTFE Coated	557	Unfilled Conductive Polypropylene	
307	Aluminum, Black Epoxy Coated	558	Conductive HDPE	
308	Stainless Steel, Black PTFE Coated	559	Glass-Filled Conductive Polypropylene	
309	Aluminum, Black PTFE Coated	570	Rulon II®	
313	Aluminum, White Epoxy Coated	580	Ryton®	
330	Zinc Plated Steel	600	PTFE (virgin material) Tetrafluorocarbon (TFE)	
332	Aluminum, Electroless Nickel Plated	603	Blue Gylon®	
333	Carbon Steel, Electroless Nickel Plated	604	PTFE	
335	Galvanized Steel	606	PTFE	
337	Silver Plated Steel	607	Envelon	
351	Food Grade Santoprene®	608	Conductive PTFE	
353	Geolast; Color: Black	610	PTFE Encapsulated Silicon	
354	Injection Molded #203-40 Santoprene® Duro 40D +/-5; Color: RED	611	PTFE Encapsulated FKM	
356	Hytrel®	632	Neoprene/Hytrel®	
357	Injection Molded Polyurethane	633	FKM/PTFE	
358	Urethane Rubber (Some Applications) (Compression Mold)	634	EPDM/PTFE	
359	Urethane Rubber	635	Neoprene/PTFE	
360	Nitrile Rubber Color coded: RED	637	PTFE, FKM/PTFE	
363	FKM (Fluorocarbon) Color coded: YELLOW	638	PTFE, Hytrel®/PTFE	
		639	Nitrile/TFE	
		643	Santoprene®/EPDM	
		644	Santoprene®/PTFE	
		656	Santoprene® Diaphragm and Check Balls/EPDM Seats	
		661	EPDM/Santoprene®	
		666	FDA Nitrile Diaphragm,	

RECYCLING

Many components of SANDPIPER® AODD pumps are made of recyclable materials. We encourage pump users to recycle worn out parts and pumps whenever possible, after any hazardous pumped fluids are thoroughly flushed.

Air Distribution Valve Assembly

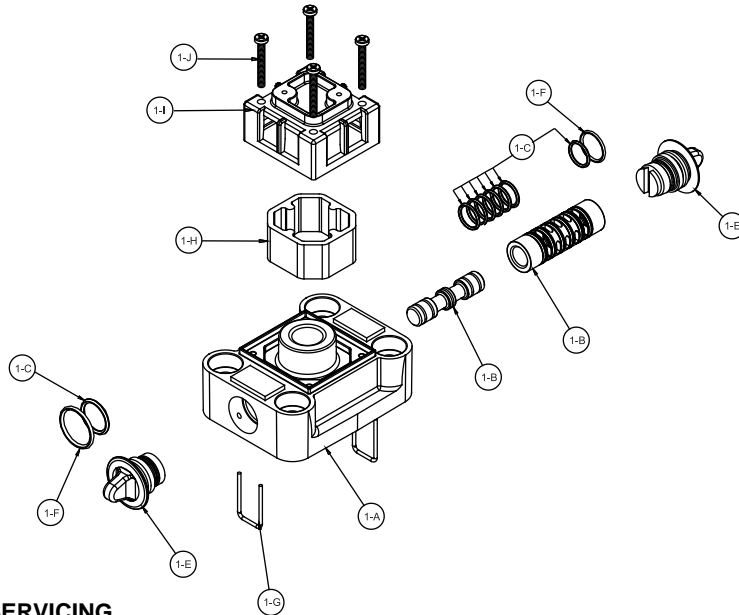

AIR DISTRIBUTION VALVE SERVICING

To service the air valve first shut off the compressed air, bleed pressure from the pump, and disconnect the air supply line from the pump.

STEP #1: See COMPOSITE REPAIR PARTS DRAWING.

Using a 3/8" wrench or socket, remove the four hex flanged capscrews (item 12). Remove the air valve assembly from the pump.

STEP #2: Disassembly of the air valve.

To access the internal air valve components first remove the two end cap retainers (item 1-G) by inserting a small flat screwdriver into the two slotted grooves on the valve body and gently lifting the retainers out.

Next remove the two end caps (item 1-E) by grasping the pull tab with finger and thumb or pliers and tugging. Inspect the two o-rings (items 1-C and 1-F) on each end cap for wear or cuts. Replace the o-rings if necessary.

Remove the spool (part of item 1-B) from the sleeve. Be careful not to scratch or damage the outer diameter of the spool. Wipe spool with a soft clean cloth and inspect for scratches or abrasive wear.

Inspect the inner diameter of the sleeve (part of item 1-B) for dirt, scratches, or other contaminants. Remove the sleeve if needed and replace with a new sleeve and spool set (item 1-B). **Note:** The sleeve and spool set is match-ground to a specified clearance. Sleeves and spools cannot be interchanged.

STEP #3: Reassembly of the air distribution valve.

Install one end cap with o-rings (items 1-E, 1-C, and 1-F) into one end of the air valve body (item 1-A). Insert one end cap retainer (item 1-G) into the two smaller holes, align with groove in the end cap, and push until the closed end of the retainer is below the flat surface of the valve body.

Remove the new sleeve and spool set (item 1-B) from the plastic bag. Carefully remove the spool from the sleeve. Install the six o-rings (item 1-C) into the six grooves on the sleeve. Apply a light coating of grease to the o-rings before installing the sleeve into the valve body. Align the slots in the sleeve with the slots in the valve body. Insert the spool into the sleeve. Be careful not to scratch or damage the spool during installation. Push the spool in until the pin touches the end cap on the opposite end. Install the remaining end cap with o-rings and retaining ring.

Fasten the air valve assembly (item 1) and gasket (item 23) to the pump, using the four hex flanged capscrews (item 12). Connect the compressed air line to the pump. The pump is now ready for operation.

MAIN AIR VALVE ASSEMBLY PARTS LIST

Item	Part Number	Description	Qty
1	031-166-000	Air Valve Assembly	1
1-A	095-106-551	Body, Air Valve	1
1-B	031-132-000	Sleeve and Spool Set	1
1-C	560-101-360	O-Ring	8
1-E	165-122-551	End Cap	2
1-F	560-026-360	O-Ring	2
1-G	675-062-115	End Cap Retainer	2
1-H	530-031-550	Muffer	1
1-I	165-109-551	Muffer Cap	1
1-J	710-011-115	Self-Tapping Screw	4

For Pumps with Virgin PTFE coated hardware:

1	031-166-002	Air Valve Assembly	1
1-G	675-062-308	End Cap Retainer	2
1-J	710-011-308	Self Tapping Screw	4

(Includes all other items used on 031-166-000 above)

For Pumps with alternate Mesh or Sound Dampening Muffers or Piped Exhaust:

1	031-168-000	Air Valve Assembly	1
---	-------------	--------------------	---

(Includes all items used on 031-166-000 above minus 1-H, 1-I and 1-J)

IMPORTANT



Read these instructions completely, before installation and start-up. It is the responsibility of the purchaser to retain this manual for reference. Failure to comply with the recommendations stated in this manual will damage the pump, and void factory warranty.

Air Distribution Valve Assembly

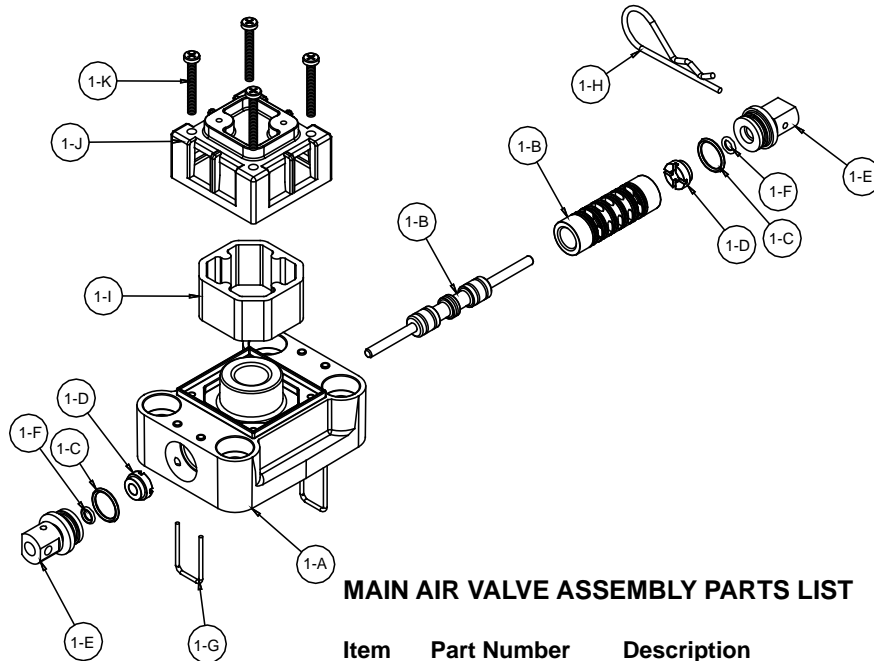

MAIN AIR VALVE ASSEMBLY PARTS LIST

AIR DISTRIBUTION VALVE WITH STROKE INDICATOR OPTION SERVICING

To service the air valve first shut off the compressed air, bleed pressure from the pump, and disconnect the air supply line from the pump.

STEP #1: See COMPOSITE REPAIR PARTS DRAWING.

Using a 3/8" wrench or socket, remove the four hex flanged capscrews (item 12). Remove the air valve assembly from the pump.

STEP #2: Disassembly of the air valve.

To access the internal air valve components first remove the two end cap retainers (item 1-G) by inserting a small flat screwdriver into the two slotted grooves on the valve body and gently lifting the retainers out.

Next remove the two end caps (item 1-E) by grasping the pull tab with finger and thumb or pliers and tugging. Inspect the two o-rings (items 1-C and 1-F) on each end cap for wear or cuts. Replace the o-rings if necessary.

Remove the spool (part of item 1-B) from the sleeve. Be careful not to scratch or damage the outer diameter of the spool. Wipe spool with a soft clean cloth and inspect for scratches or abrasive wear.

Inspect the inner diameter of the sleeve (part of item 1-B) for dirt, scratches, or other contaminants. Remove the sleeve if needed and replace with a new sleeve and spool set (item 1-B). **Note:** The sleeve and spool set is match-ground to a specified clearance. Sleeves and spools cannot be interchanged.

STEP #3: Reassembly of the air distribution valve.

Install one end cap with o-rings (items 1-E, 1-C, and 1-F) into one end of the air valve body (item 1-A). Insert one end cap retainer (item 1-G) into the two smaller holes, align with groove in the end cap, and push until the closed end of the retainer is below the flat surface of the valve body.

Remove the new sleeve and spool set (item 1-B) from the plastic bag. Carefully remove the spool from the sleeve. Install the six o-rings (item 1-C) into the six grooves on the sleeve. Apply a light coating of grease to the o-rings before installing the sleeve into the valve body. Align the slots in the sleeve with the slots in the valve body. Insert the spool into the sleeve. Be careful not to scratch or damage the spool during installation. Push the spool in until the pin touches the end cap on the opposite end. Install the remaining end cap with o-rings and retaining ring.

Fasten the air valve assembly (item 1) and gasket (item 23) to the pump, using the four hex flanged capscrews (item 12).

Connect the compressed airline to the pump. The pump is now ready for operation.

IMPORTANT: Remove the safety clip. The pump will not function properly until it is removed. The pump is now ready for operation.

Item	Part Number	Description	Qty
1	031-167-000	Air Valve Assembly	1
1-A	095-106-559	Body, Air Valve	1
1-B	031-134-000	Sleeve and Spool Set	1
1-C	560-101-360	O-Ring	8
1-D	132.030.552	Bumper	2
1-E	165-123-147	End Cap	2
1-F	560-029-360	O-Ring	2
1-G	675-062-115	End Cap Retainer	2
1-H	210-008-330	Safety Clip	1
1-I	530-031-550	Muffler	1
1-J	165-109-559	Muffler Cap	1
1-K	710-011-115	Self-Tapping Screw	4

For Pumps with Virgin PTFE coated hardware:

1	031-167-002	Air Valve Assembly	1
1-G	675-062-308	End Cap Retainer	2
1-J	710-011-308	Self Tapping Screw	4

(Includes all other items used on 031-166-000 above)

For Pumps with alternate Mesh or Sound Dampening Mufflers or Piped Exhaust:

1	031-169-000	Air Valve Assembly	1
---	-------------	--------------------	---

(Includes all items used on 031-167-000 above minus 1-H, 1-I and 1-J)

IMPORTANT



Read these instructions completely, before installation and start-up. It is the responsibility of the purchaser to retain this manual for reference. Failure to comply with the recommendations stated in this manual will damage the pump, and void factory warranty.

Pilot Valve Assembly

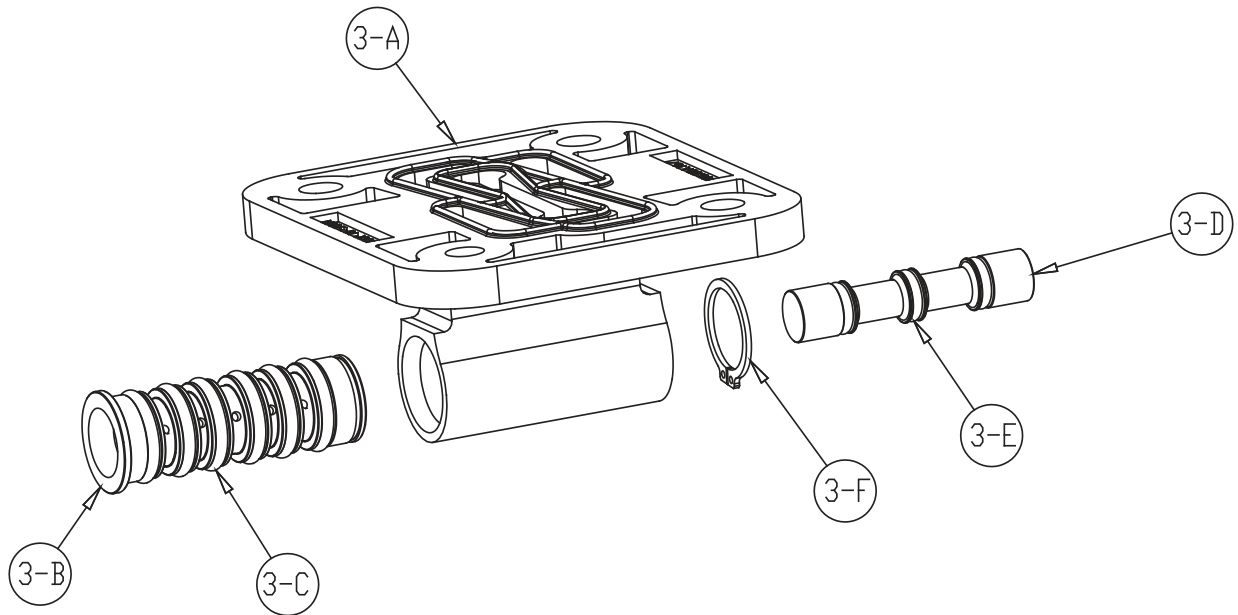

PILOT VALVE ASSEMBLY PARTS LIST

ITEM	PART NUMBER	DESCRIPTION	QTY
3	095-091-000	Pilot Valve Assembly	1
3-A	095-087-551	Valve Body	1
3-B	755-051-000	Sleeve (With O-rings)	1
3-C	560-033-379	O-ring (Sleeve)	6
3-D	775-055-000	Spool (With O-rings)	1
3-E	560-023-379	O-ring (Spool)	3
3-F	675-037-080	Retaining Ring	1

4: AIR END

PILOT VALVE SERVICING

To service the pilot valve first shut off the compressed air supply, bleed the pressure from the pump, and disconnect the air supply line from the pump.

STEP #1: See pump assembly drawing.

Using a 7/16" wrench or socket, remove the four capscrews (item 12). Remove the air inlet cap (item 8) and air inlet gasket (item 18). The pilot valve assembly (item 3) can now be removed for inspection and service.

STEP #2: Disassembly of the pilot valve.

Remove the pilot valve spool (item 3-D). Wipe clean and inspect spool and o-rings for dirt, cuts or wear. Replace the o-rings and spool if necessary.

Remove the retaining ring (item 3-F) from the end of the sleeve (item 3-b) and remove the sleeve from the valve body (item 3-A). Wipe clean and inspect sleeve and o-rings for dirt, cuts or wear. Replace the o-rings and sleeve if necessary.

STEP #3: Re-assembly of the pilot valve.

Generously lubricate outside diameter of the sleeve and o-rings. Then carefully insert sleeve into valve body. Take CAUTION when inserting sleeve, not to shear any o-rings. Install retaining ring to sleeve. Generously lubricate outside diameter of spool and o-rings. Then carefully insert spool into sleeve. Take CAUTION when inserting spool, not to shear any o-rings. Use BP-LS-EP-2 multipurpose grease, or equivalent.

STEP #4: Re-install the pilot valve assembly into the intermediate.

Be careful to align the ends of the pilot valve stem between the plunger pins when inserting the pilot valve into the cavity of the intermediate.

Re-install the gasket, air inlet cap and capscrews. Connect the air supply to the pump. The pump is now ready for operation.

Intermediate Assembly

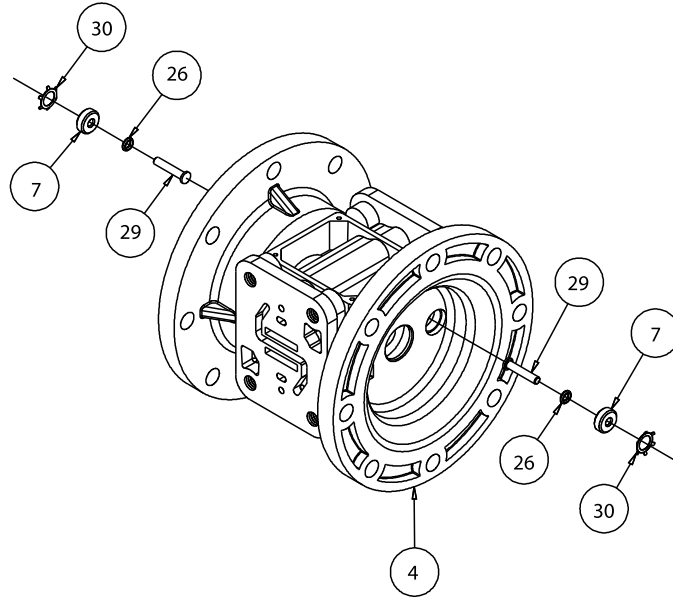

ACTUATOR PLUNGER SERVICING

To service the actuator plunger first shut off the compressed air supply, bleed the pressure from the pump, and disconnect the air supply line from the pump.

Step #1: See PUMP ASSEMBLY DRAWING.

Using a 3/8" wrench or socket, remove the four capscrews (items 12). Remove the air inlet cap (item 8) and air inlet gasket (item 20). The pilot valve assembly (item 3) can now be removed.

Step #2: Servicing the actuator plungers. See PUMP ASSEMBLY DRAWING.

The actuator plungers (items 28) can be reached through the stem cavity of the pilot valve in the intermediate bracket (item 4). To service bushings, o-rings and retaining rings, see Intermediate Drawing.

Remove the plungers (items 28) from the bushings (item 7) in each end of the intermediate cavity. Inspect for wear or damage. Replace plunger as needed. Apply a light coating of grease to each o-ring and re-install the plungers in to the bushings. Push the plungers in as far as they will go.

Step #3: Re-install the pilot valve assembly into the intermediate assembly.

Be careful to align the ends of the stem between the plungers when inserting the stem of the pilot valve into the cavity of the intermediate. Re-install the gasket (item 20), air inlet cap (item 8) and capscrews (items 12).

Connect the air supply to the pump. The pump is now ready for operation.

PLUNGER BUSHING, O-RING, AND RETAINING RING SERVICING

To service the plunger bushing components first remove the two retaining rings (items 30) using a small flat screwdriver. **Note:** It is recommended that new retaining rings be installed.

Next remove the two plunger bushings (items 7). Inspect the bushings for wear or scratches. Replace the bushings as necessary.

Inspect the two o-rings (25) for cuts and/or wear.

INTERMEDIATE ASSEMBLY REPAIR PARTS LIST

Item	Part Number	Description	Qty
4	114-023-551	Bracket, Intermediate	1
7	135-036-506	Bushing, Plunger	2
25	560-001-360	O-Ring	2
28	620-019-115	Plunger, Actuator	2
30	675-042-115	Ring, Retaining*	2

***NOTE:** It is recommended that when plunger components are serviced, new retaining rings be installed.

4: AIR END

⚠ IMPORTANT



When the pumped product source is at a higher level than the pump (flooded suction condition), pipe the exhaust higher than the product source to prevent siphoning spills. In the event of a diaphragm failure a complete rebuild of the center section is recommended.

Modular Check Valve Drawing

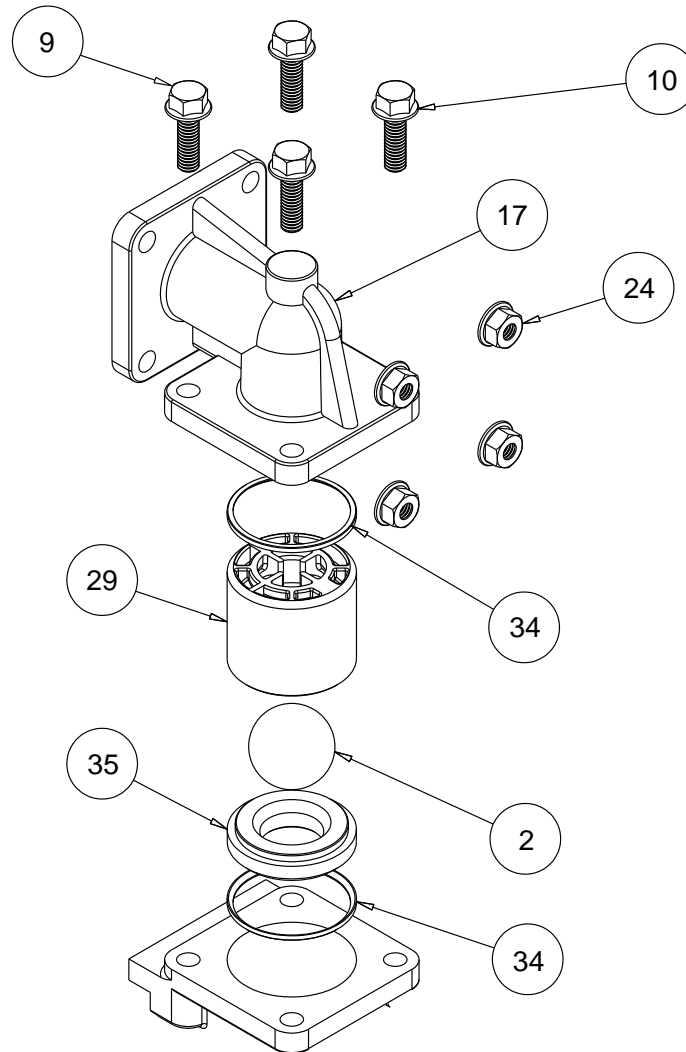

4: AIR END

MODULAR CHECK BALL VALVE SERVICING

Before servicing the check valves, first shut off the suction line and then the discharge line to the pump. Next, shut off the compressed air supply, bleed air pressure from the pump, and disconnect the air supply line from the pump. Drain any remaining fluid from the pump. The pump can now be removed for service.

To access the modular check valve, remove the elbows (items 17 from pump composite repair parts drawing). Use a 1/2" wrench or socket to remove the fasteners. Once the elbows are removed, the modular check valves can be seen in the cavities of the outer chamber (items 14).

Next remove the check valve seal (item 34). Inspect the seal for cuts or pinched areas. Replace seal as needed.

Disassemble the component parts of each modular check valve. Inspect the check valve retainer (item 29) for cuts, abrasive wear, or embedded materials.

Replace as needed.

Inspect the check balls (items 2) for wear, abrasion, or cuts on the spherical surface. The check valve seats (items 35) should be inspected for cuts, abrasive wear, or embedded material on the surfaces of both the external and internal chambers. The spherical surface of the check balls must seat flush to the surface of the inner chamfer on the check valve seats for the pump to operate to peak efficiency. Replace any worn or damaged parts as necessary.

Remove the check valve seal (item 34). Inspect the seal for cuts or pinched areas. Replace seal as needed.

RE-ASSEMBLE THE MODULAR CHECK VALVES.

Place a check valve seal (item 34) into the cavity of the outer chamber (item 14). Make sure the chamfer side of the seal faces out. Insert the modular check valve into the outer chamber with the retainer facing up. Install a check valve seal (item 34). Make sure the chamfer side of the seals face the chamfer on the check valve seat or retainer.

The pump can now be reassembled, reconnected and returned to operation.

Diaphragm Service Drawing

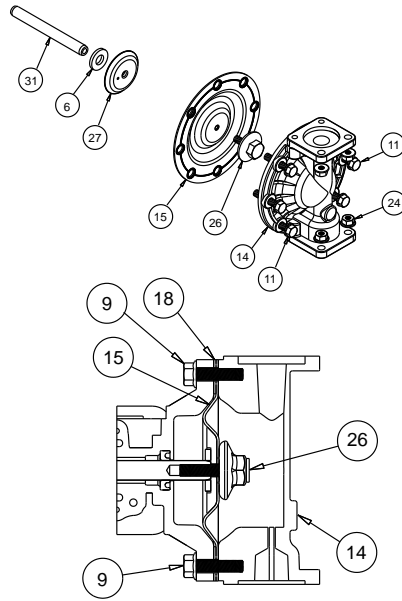

Diaphragm Orientation
Install diaphragm and spacer as shown above.

Diaphragm Service Drawing, With Overlay

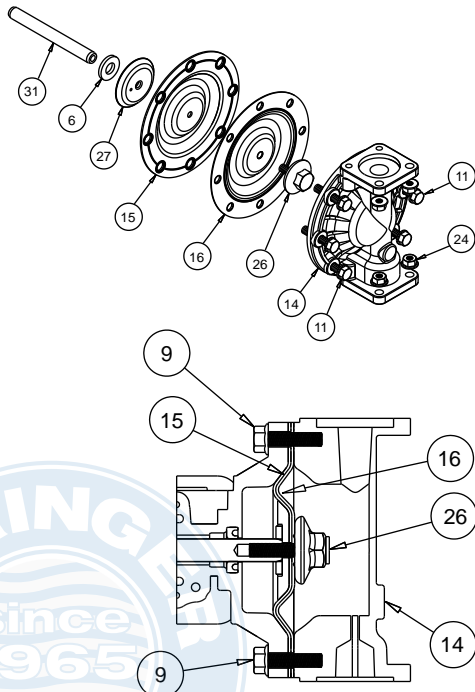

Diaphragm Orientation
Install diaphragm and overlay as shown above.

Diaphragm Service Drawing with One-Piece Bonded

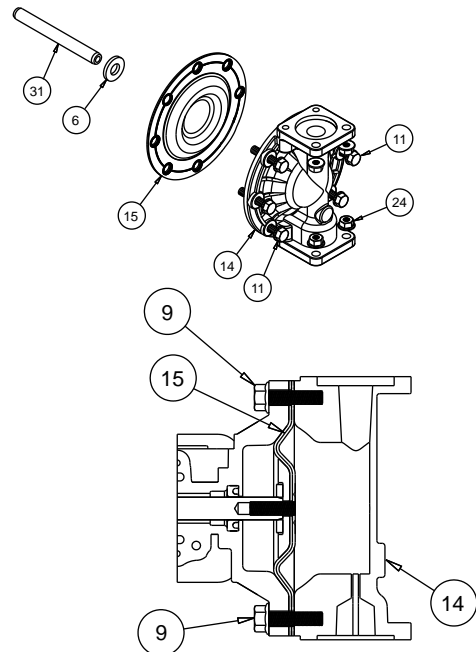

Diaphragm Orientation
Install diaphragm (286.116.000 only) as shown above.

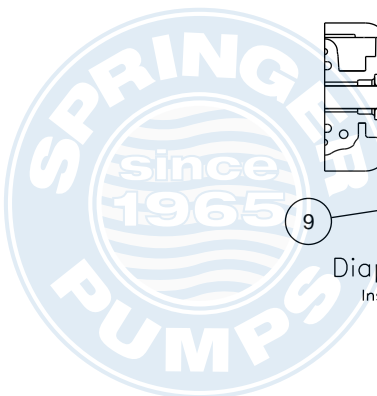

Diaphragm Servicing

DIAPHRAGM SERVICING

To service the diaphragms first shut off the suction, then shut off the discharge lines to the pump. Shut off the compressed air supply, bleed the pressure from the pump, and disconnect the air supply line from the pump. Drain any remaining liquid from the pump.

Step #1: See the pump composite repair parts drawing, and the diaphragm servicing illustration.

Using a 1/2" wrench or socket, remove the 16 capscrews (items 9 & 10), and nuts that fasten the elbows (items 17) to the outer chambers (items 14). Remove the elbows with the manifolds and spacers attached.

Step #2: Removing the outer chambers.

Using a 1/2" wrench or socket, remove the 16 capscrews (items 9 & 11), and nuts that fasten the outer chambers, diaphragms, and intermediate bracket (items 4) together.

Step #3: Removing the diaphragm assemblies.

Use a 3/4" (19mm) wrench or six pointed socket to remove the diaphragm assemblies (outer plate, diaphragm, and inner plate) from the diaphragm rod (item 31) by turning counterclockwise.

Insert a 6-32 set screw into the smaller tapped hole in the inner diaphragm plate (item 27). Insert the protruding stud and the 6-32 fastener loosely into a vise. Use a 3/4" wrench or socket to remove the outer diaphragm plate (item 26) by turning counterclockwise. Inspect the diaphragm (item 15) for cuts, punctures, abrasive wear or chemical attack. Replace the diaphragms if necessary.

Step #4: Installing the diaphragms.

Push the threaded stud of the outer diaphragm plate through the center hole of the diaphragm. Thread the inner plate clockwise onto the stud. Use a torque wrench to tighten the diaphragm assembly together to 90 in Lbs. (10.17 Newton meters) 120 in lbs.

Santoprene (13.56 Newton meters). Allow a minimum of 15 minutes to elapse after torquing, then re-torque the assembly to compensate for stress relaxation in the clamped assembly.

Step #5: Installing the diaphragm assemblies to the pump.

Make sure the bumper (item 6) is installed over the diaphragm rod.

Thread the stud of the one diaphragm assembly clockwise into the tapped hole at the end of the diaphragm rod (item 31) until the inner diaphragm plate is flush to the end of the rod. Insert rod into pump.

Align the bolt holes in the diaphragm with the bolt pattern in the inner chamber (item 4). Make sure the molded directional arrows on the diaphragm point vertically.

Fasten the outer chamber (item 14) to the pump, using the capscrews (items 9 & 11), hex nuts and flat washers.

On the opposite side of the pump, pull the diaphragm rod out as far as possible. Make sure the bumper (item 6) is installed over the diaphragm rod.

Thread the stud of the remaining diaphragm assembly clockwise into the tapped hole at the end of the diaphragm rod (item 31) as far as possible and still allow for alignment of the bolt holes in the diaphragm with the bolt pattern in the inner chamber. The molded directional arrows on the diaphragm must point vertically.

Fasten the remaining outer chamber (item 14) to the pump, using the capscrews (items 9 & 11) and nuts.

Step #6: Re-install the elbow/spacer/manifold assemblies to the pump, using the capscrews (items 9 & 10) and nuts.

The pump is now ready to be re-installed, connected and returned to operation.

OVERLAY DIAPHRAGM SERVICING

The PTFE overlay diaphragm (item 16) is designed to fit snugly over the exterior of the standard TPE diaphragm

(item 15).

The molded directional arrows on the overlay diaphragm must point vertically.

Follow the same procedures described for the standard diaphragm for removal and installation.

ONE PIECE DIAPHRAGM SERVICING (Bonded PTFE with integral plate)

The One Piece diaphragm has a threaded stud installed in the integral plate at the factory. The inner diaphragm plate has a through hole instead of a threaded hole.

Place the inner plate over the diaphragm stud and thread the first diaphragm / inner plate onto the diaphragm rod only until the inner plate contacts the rod. Do not tighten.

A small amount of grease may be applied between the inner plate and the diaphragm to facilitate assembly.

Insert the diaphragm / rod assembly into the pump and install the outer chamber. Turn the pump over and thread the second diaphragm / inner plate onto the diaphragm rod. Turn the diaphragm until the inner plate contacts the rod and hand tighten the assembly. Continue tightening until the bolt holes align with the inner chamber holes. **DO NOT LEAVE THE ASSEMBLY LOOSE.**

⚠ IMPORTANT

 *Read these instructions completely, before installation and start-up. It is the responsibility of the purchaser to retain this manual for reference. Failure to comply with the recommendations stated in this manual will damage the pump, and void factory warranty.*

Solenoid Shifted Air Valve

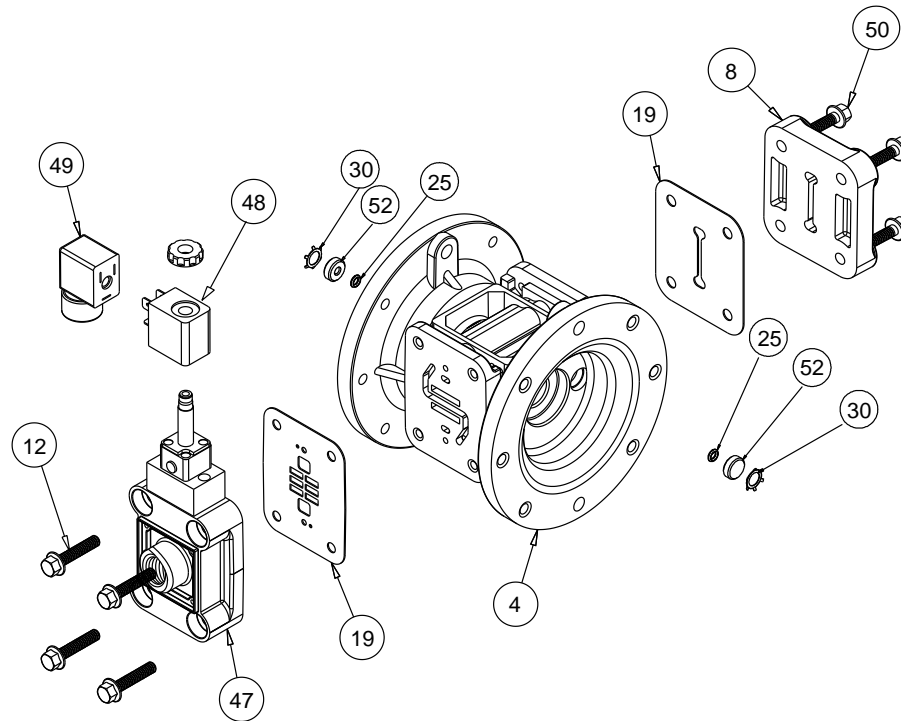

SOLENOID SHIFTED AIR DISTRIBUTION VALVE OPTION

Warren Rupp's solenoid shifted, air distribution valve option utilizes electrical signals to precisely control your MARATHON's speed. The solenoid coil is connected to a customer - supplied control. Compressed air provides the pumping power, while electrical signals control pump speed (pumping rate).

OPERATION

The Solenoid Shifted MARATHON has a solenoid operated, air distribution valve in place of the standard MARATHON's pilot operated, air distribution valve. Where a pilot valve is normally utilized to cycle the pump's air distribution valve, an electric solenoid is utilized. As the solenoid is powered, one of the pump's air chambers is pressurized while the other chamber is exhausted. When electric power is turned off, the solenoid shifts and the pressurized chamber is exhausted while the other chamber is pressurized. By alternately applying and removing power to the solenoid, the pump cycles much like a standard MARATHON pump, with one exception. This option provides a way to precisely control and monitor pump speed.

BEFORE INSTALLATION

Before wiring the solenoid, make certain it is compatible with your system voltage.

Solenoid Shifted Air Valve Parts List

Item	Part Number	Description	Qty
4	114-023-551	Bracket, Intermediate	1
47	893-099-000	Solenoid Valve, NEMA4	1
48	219-001-000	Solenoid Coil, 24VDC	1
	219-004-000	Solenoid Coil, 24VAC/12VDC	1
	219-002-000	Solenoid Coil, 120VAC	1
	219-003-000	Solenoid Coil, 240VAC	1
49	241-001-000	Connector, Conduit	1
50	171-065-115	Cap screw, Flanged 1/4-20 x 1.004	1
52	618-050-150	Plug (Replaces item 7)	2

For Explosion Proof Solenoid Coils:

48	219-009-001	Solenoid Coil, 120VAC 60Hz	1
	219-009-002	Solenoid Coil, 240VAC 60Hz	1
	219-009-003	Solenoid Coil, 12VDC	1
	219-009-004	Solenoid Coil, 24VDC	1
	219-009-005	Solenoid Coil, 110VAC 50Hz	1
	219-009-006	Solenoid Coil, 230VAC 50Hz	1

6: OPTIONAL

Optional Muffler Configurations



OPTION 0

530-031-550 Integral Muffler uses (1) Cap and (4) 706-027-115 Machine Screw to hold it in place.

OPTION 1

530-024-000 Sound Dampening Muffler screws directly into the Air Valve body. This muffler is equipped with a porous plastic element.

OPTION 2

530-023-000 Mesh Muffler screws directly into the Air Valve Body. This muffler is equipped with a metal element.



OPTION 6

530-035-000 Metal Muffler screws directly into the Air Body.

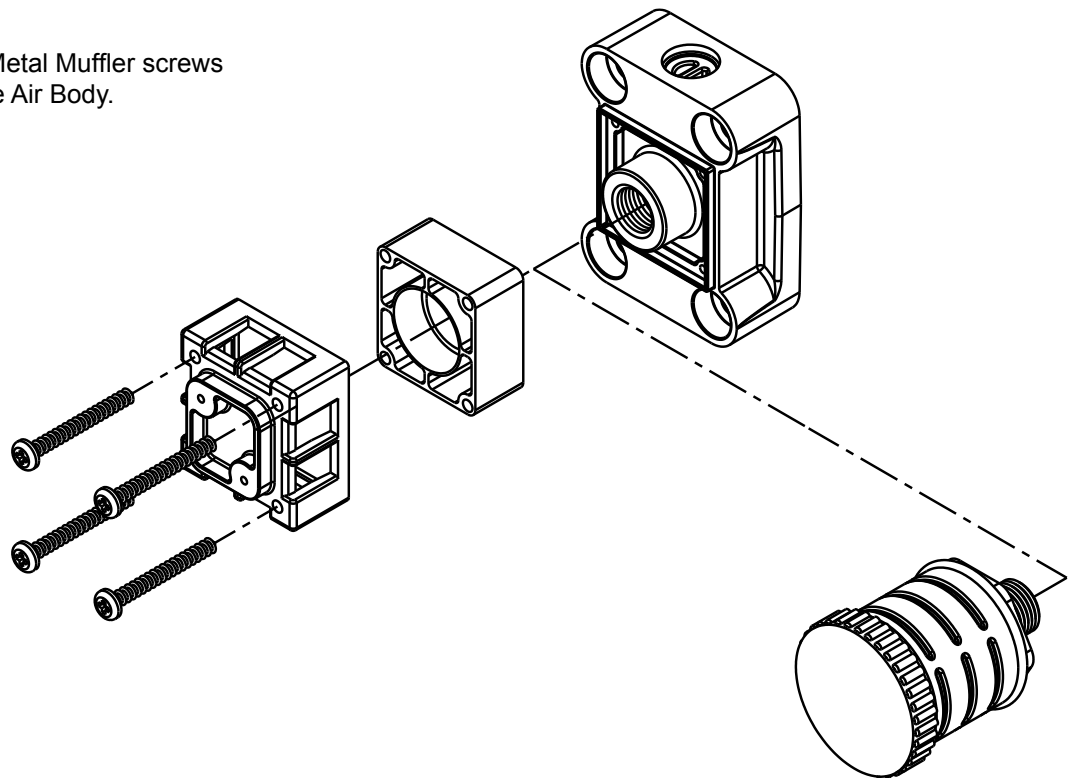

6: OPTIONAL

Option 6

Option 1 and 2

Pulse Output Kit

PULSE OUTPUT KIT OPTION

This pump can be fitted with a Pulse Output Kit. This converts the mechanical strokes of the pump to an electrical signal which interfaces with the Stroke Counter/ Batch Controller or user control devices such as a PLC.

See the individual kits listed on the Pump Repair Parts List for further information..

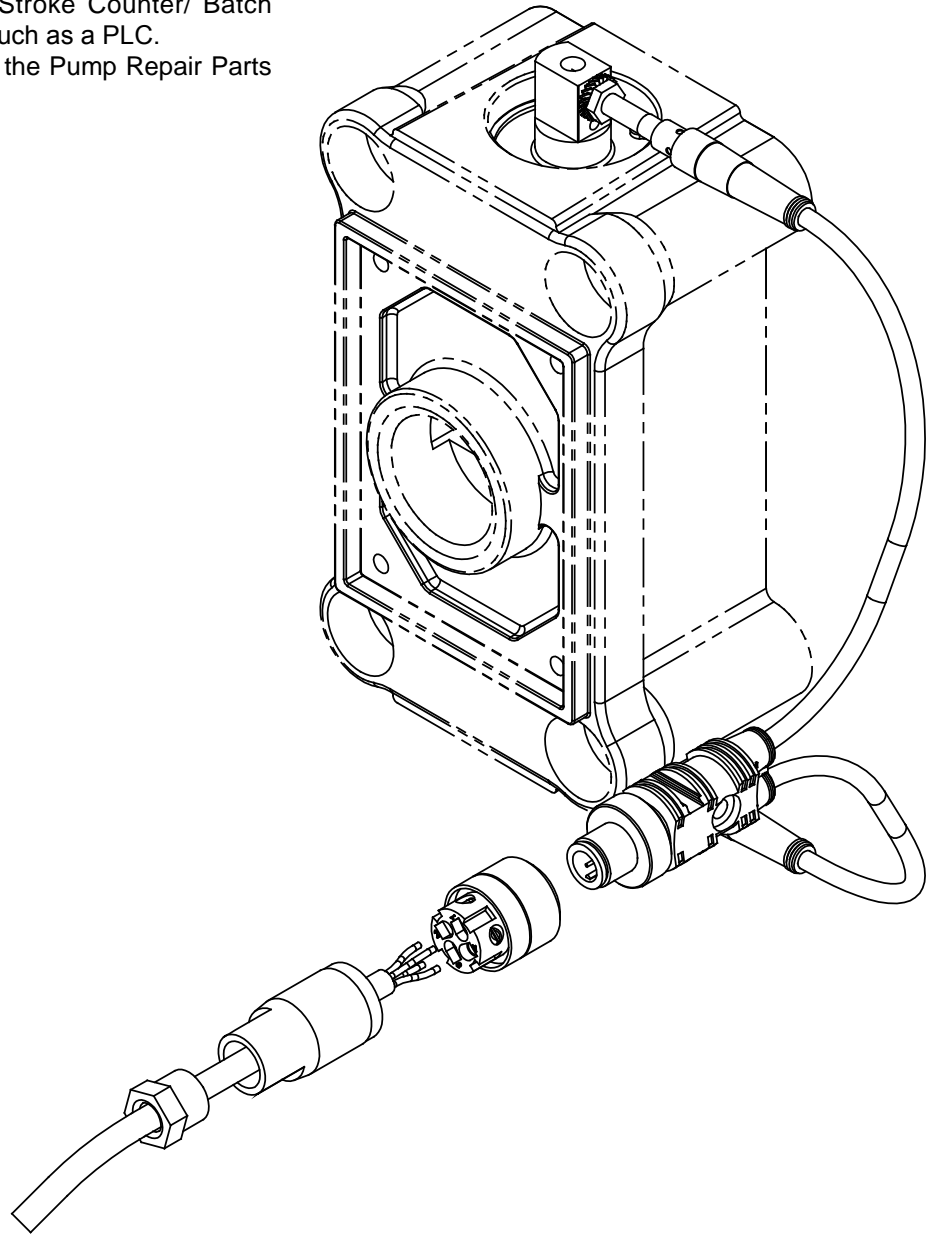

5 - YEAR Limited Product Warranty

Warren Rupp, Inc. ("Warren Rupp") warrants to the original end-use purchaser that no product sold by Warren Rupp that bears a Warren Rupp brand shall fail under normal use and service due to a defect in material or workmanship within five years from the date of shipment from Warren Rupp's factory. Warren Rupp brands include Warren Rupp®, SANDPIPER®, SANDPIPER Signature Series™, MARATHON®, Porta-Pump®, SludgeMaster™ and Tranquilizer®.

The use of non-OEM replacement parts will void (or negate) agency certifications, including CE, ATEX, CSA, 3A and EC1935 compliance (Food Contact Materials). Warren Rupp, Inc. cannot ensure nor warrant non-OEM parts to meet the stringent requirements of the certifying agencies.

**WARREN
RUPP, INC.**

Declaration of Conformity

**Manufacturer: Warren Rupp, Inc., 800 N. Main Street
Mansfield, Ohio, 44902 USA**

Certifies that Air-Operated Double Diaphragm Pump Series: HDB, HDF, M Non-Metallic, S Non-Metallic, M Metallic, S Metallic, T Series, G Series, U Series, EH and SH High Pressure, RS Series, W Series, SMA and SPA Submersibles, and Tranquilizer® Surge Suppressors comply with the European Community Directive 2006/42/EC on Machinery, according to Annex VIII. This product has used Harmonized Standard EN809:1998+A1:2009, Pumps and Pump Units for Liquids - Common Safety Requirements, to verify conformance.

Signature of authorized person

October 20, 2005

Date of issue

Director of Engineering

Title

February 27, 2017

Date of revision

Authorised Representative:
IDEX Pump Technologies
R79 Shannon Industrial Estate
Shannon, Co. Clare, Ireland

Attn: Barry McMahon

Revision Level: F

CE



7. WARRANTY

WARREN RUPP, INC.

EC / EU Declaration of Conformity

The objective of the declaration described is in conformity with the relevant Union harmonisation legislation: Directive 94/9/EC (until April 19, 2016) and Directive 2014/34/EU (from April 20, 2016).

Manufacturer:

Warren Rupp, Inc.
A Unit of IDEX Corporation
800 North Main Street
P.O. Box 1568
Mansfield, OH 44902 USA

Applicable Standard:

EN13463-1: 2001
EN13463-5: 2003
EN60079-25: 2004

Harmonised Standard:

EN13463-1: 2009
EN13463-5: 2011
EN60079-25:2010

The harmonised standards have been compared to the applicable standards used for certification purposes and no changes in the state of the art technical knowledge apply to the listed equipment.

AODD Pumps and Surge Suppressors

Technical File No.: 203104000-1410/MER

AODD (Air-Operated Double Diaphragm) Pumps

EC Type Examination Certificate No. Pumps: KEMA 09ATEX0071 X

DEKRA Certification B.V. (0344)

Meander 1051
6825 MJ Arnhem
The Netherlands

Hazardous Locations Applied:

I M1 c	II 1 G c T5
II 2 G Ex ia c IIC T5	II 1 D c T100°C
II 2 D Ex c iaD 20 IP67 T100°C	II 2 G c T5
II 2 G Eex m c IIT5	II 2 D c T100°C
II 2 D c IP65 T100°C	II 2 G c IIB T5

SANDPIPER®

A WARREN RUPP, INC. BRAND

Tranquilizer®

DATE/APPROVAL/TITLE:

18 March 2016

David Roseberry
David Roseberry, Director of Engineering