

# SERVICE & OPERATING MANUAL

## Original Instructions

Certified Quality



SAI GLOBAL

ISO 9001 Certified  
ISO 14001 Certified

Member of  
*Hydraulic*

EAC

Warren Rupp, Inc.  
A Unit of IDEX Corporation  
800 N. Main St.,  
Mansfield, Ohio 44902 USA  
Telephone (419) 524.8388  
Fax (419) 522.7867  
SANDPIPERPUMP.COM

**IDEX**

©2017 Warren Rupp, Inc.

# GH2M

## Gas Duty - High Pressure Design Level 1

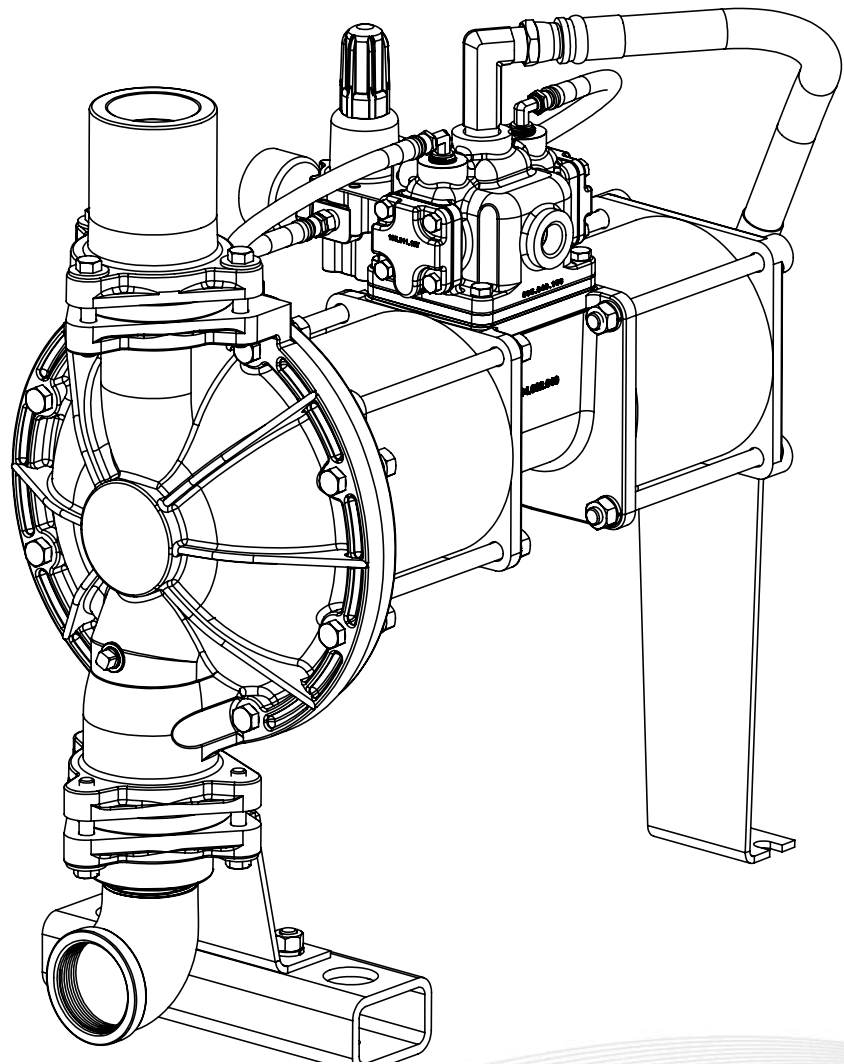

1: PUMP SPECS

2: INSTAL & OP

3: EXP VIEW

4: AIR END

5: WET END

6: OPTIONAL

7: WARRANTY

**SANDPIPER®**  
A WARREN RUPP, INC. BRAND

SANDPIPERPUMP.COM

# Safety Information

## IMPORTANT



Read the safety warnings and instructions in this manual before pump installation and start-up. Failure to comply with the recommendations stated in this manual could damage the pump and void factory warranty.



When the pump is used for materials that tend to settle out or solidify, the pump should be flushed after each use to prevent damage. In freezing temperatures the pump should be completely drained between uses.

## CAUTION



Before pump operation, inspect all fasteners for loosening caused by gasket creep. Retighten loose fasteners to prevent leakage. Follow recommended torques stated in this manual.



Nonmetallic pumps and plastic components are not UV stabilized. Ultraviolet radiation can damage these parts and negatively affect material properties. Do not expose to UV light for extended periods of time.



**WARNING**  
The use of non-OEM replacement parts will void (or negate) agency certifications, including CE, ATEX, CSA, 3A and EC1935 compliance (Food Contact Materials). Warren Rupp, Inc. cannot ensure nor warrant non-OEM parts to meet the stringent requirements of the certifying agencies.

## RECYCLING

Many components of SANDPIPER® AODD pumps are made of recyclable materials. We encourage pump users to recycle worn out parts and pumps whenever possible, after any hazardous pumped fluids are thoroughly flushed.

## WARNING



When used for toxic or aggressive fluids, the pump should always be flushed clean prior to disassembly.



Before maintenance or repair, shut off the compressed air line, bleed the pressure, and disconnect the air line from the pump. Be certain that approved eye protection and protective clothing are worn at all times. Failure to follow these recommendations may result in serious injury or death.



Airborne particles and loud noise hazards. Wear eye and ear protection.



In the event of diaphragm rupture, pumped material may enter the air end of the pump, and be discharged into the atmosphere. If pumping a product that is hazardous or toxic, the air exhaust must be piped to an appropriate area for safe containment.



Take action to prevent static sparking. Fire or explosion can result, especially when handling flammable liquids. The pump, piping, valves, containers and other miscellaneous equipment must be properly grounded.



This pump is pressurized internally with air pressure during operation. Make certain that all fasteners are in good condition and are reinstalled properly during reassembly.



Use safe practices when lifting

## Grounding ATEX Pumps

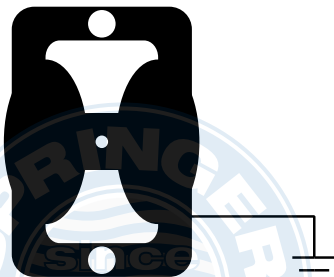

ATEX compliant pumps are suitable for use in explosive atmospheres when the equipment is properly grounded in accordance with local electrical codes. Pumps equipped with electrically conductive diaphragms are suitable for the transfer of conductive or non-conductive fluids of any explosion group. When operating pumps equipped with non-conductive diaphragms that exceed the maximum permissible projected area, as defined in EN 13463-1: 2009 section 6.7.5 table 9, the following protection methods must be applied:

- Equipment is always used to transfer electrically conductive fluids or
- Explosive environment is prevented from entering the internal portions of the pump, i.e. dry running

For further guidance on ATEX applications, please consult the factory.

# Table of Contents

## **SECTION 1: PUMP SPECIFICATIONS.....1**

- Explanation of Nomenclature
- Performance
- Materials
- Dimensional Drawings

## **SECTION 2: INSTALLATION & OPERATION.....5**

- Principle of Pump Operation
- Recommended Installation Guide
- Troubleshooting Guide

## **SECTION 3: EXPLODED VIEW .....8**

- Composite Repair Parts Drawing
- Composite Repair Parts List
- Down Ported Option Drawing
- Material Codes

## **SECTION 4: AIR END.....12**

- Air Distribution Valve Assembly
- Pilot Valve Assembly

## **SECTION 5: WET END .....14**

- Diaphragm Servicing

## **SECTION 7: WARRANTY & CERTIFICATES ....15**

- Warranty
- CE Declaration of Conformity - Machinery
- ATEX Declaration of Conformity



# Explanation of Pump Nomenclature

1: PUMP SPECS

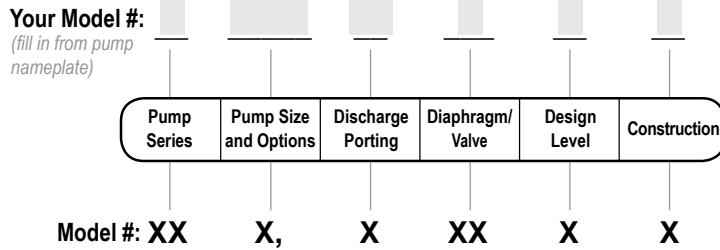

**Pump Series**

GH Gas Duty - High Pressure

**Pump Size & Options**

2 2"

**Discharge Porting Position**

T Top

**Diaphragm Check Valve Materials**

B Nitrile

C FKM with PTFE

GB Nitrile Backup with PTFE Overlay and PTFE Check Balls

GN Neoprene Backup with PTFE Overlay and PTFE Check Balls

V FKM (Stainless Wetted Only)

**Design Level**

1

**Construction**

I Cast Iron Wetted

S Stainless

Your Serial #: *(fill in from pump nameplate)* \_\_\_\_\_

## ATEX Detail

|   | ATEX Detail                  | Construction | Options |
|---|------------------------------|--------------|---------|
|  | II 2G c T5<br>II 2D c T100°C | I,S          | N/A     |



# Performance

## GH2 HIGH PRESSURE

### SUCTION/DISCHARGE PORT SIZE

- GH2: 2" NPT

### CAPACITY

- 0 to 74 gallons per minute (0 to 280 liters per minute)

### AIR DISTRIBUTION VALVE

- No-lube, no-stall design

### SOLIDS-HANDLING

- Up to .25" in. (6.5 mm)

### HEADS UP TO

- 250 psi or 577 ft. of water (17 bar or 176 meters of water)

### MAXIMUM OPERATING PRESSURE

- 125 psi (8.6 bar)

### DISPLACEMENT/STROKE

- .36 Gallon / 1.3 liter

### SHIPPING WEIGHT

- Cast Iron 172lbs. (78kg)
- Stainless Steel 176 lbs. (80kg)

### Model GH2 Performance Curve

Performance based on the following: elastomer fitted pump, flooded suction, water at ambient conditions. The use of other materials and varying hydraulic conditions may result in deviations in excess of 5%.

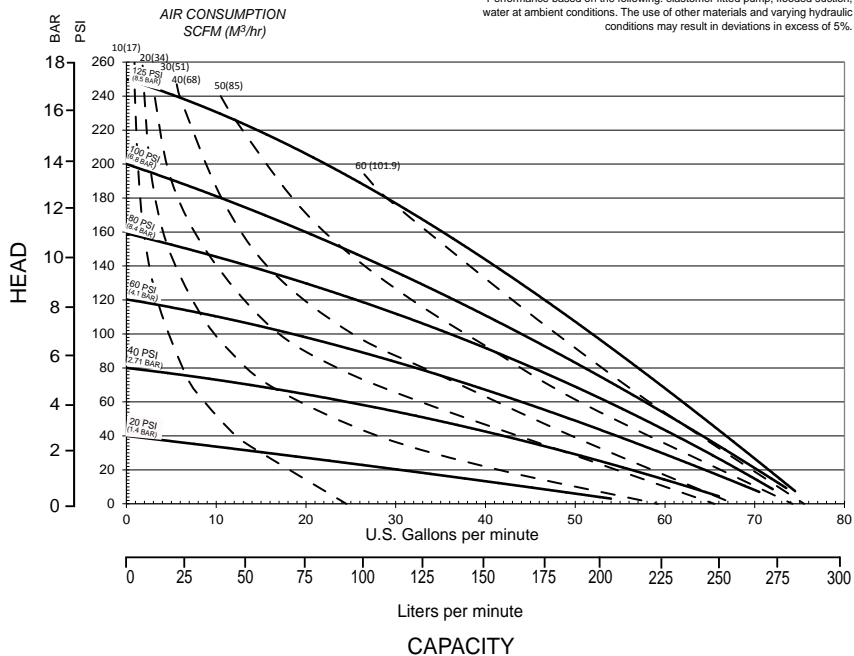

## Materials

| Material Profile:   | Operating Temperatures: |                |
|---|-------------------------|----------------|
|   | Max.                    | Min.           |
| <b>CAUTION!</b> Operating temperature limitations are as follows:   |                         |                |
| <b>Conductive Acetal:</b> Tough, impact resistant, ductile. Good abrasion resistance and low friction surface. Generally inert, with good chemical resistance except for strong acids and oxidizing agents.   | 190°F<br>88°C           | -20°F<br>-29°C |
| <b>EPDM:</b> Shows very good water and chemical resistance. Has poor resistance to oils and solvents, but is fair in ketones and alcohols.  | 280°F<br>138°C          | -40°F<br>-40°C |
| <b>FKM:</b> (Fluorocarbon) Shows good resistance to a wide range of oils and solvents; especially all aliphatic, aromatic and halogenated hydrocarbons, acids, animal and vegetable oils. Hot water or hot aqueous solutions (over 70°F(21°C)) will attack FKM.                 | 350°F<br>177°C          | -40°F<br>-40°C |
| <b>Hytrel®:</b> Good on acids, bases, amines and glycols at room temperatures only.   | 220°F<br>104°C          | -20°F<br>-29°C |
| <b>Neoprene:</b> All purpose. Resistance to vegetable oils. Generally not affected by moderate chemicals, fats, greases and many oils and solvents. Generally attacked by strong oxidizing acids, ketones, esters and nitro hydrocarbons and chlorinated aromatic hydrocarbons. | 200°F<br>93°C           | -10°F<br>-23°C |
| <b>Nitrile:</b> General purpose, oil-resistant. Shows good solvent, oil, water and hydraulic fluid resistance. Should not be used with highly polar solvents like acetone and MEK, ozone, chlorinated hydrocarbons and nitro hydrocarbons.                                      | 190°F<br>88°C           | -10°F<br>-23°C |
| <b>Nylon:</b> 6/6 High strength and toughness over a wide temperature range. Moderate to good resistance to fuels, oils and chemicals.  | 180°F<br>82°C           | 32°F<br>0°C    |

**Ambient temperature range:** -20°C to +40°C  
**Process temperature range:** -20°C to +80°C for models rated as category 1 equipment  
 -20°C to +100°C for models rated as category 2 equipment

In addition, the ambient temperature range and the process temperature range do not exceed the operating temperature range of the applied non-metallic parts as listed in the manuals of the pumps.

|  |                |                |
|--|----------------|----------------|
| <b>Polypropylene:</b> A thermoplastic polymer. Moderate tensile and flex strength. Resists strong acids and alkali. Attacked by chlorine, fuming nitric acid and other strong oxidizing agents.  | 180°F<br>82°C  | 32°F<br>0°C    |
| <b>PVDF:</b> (Polyvinylidene Fluoride) A durable fluoroplastic with excellent chemical resistance. Excellent for UV applications. High tensile strength and impact resistance.   | 250°F<br>121°C | 0°F<br>-18°C   |
| <b>Santoprene®:</b> Injection molded thermoplastic elastomer with no fabric layer. Long mechanical flex life. Excellent abrasion resistance.   | 275°F<br>135°C | -40°F<br>-40°C |
| <b>UHMW PE:</b> A thermoplastic that is highly resistant to a broad range of chemicals. Exhibits outstanding abrasion and impact resistance, along with environmental stress-cracking resistance.  | 180°F<br>82°C  | -35°F<br>-37°C |
| <b>Urethane:</b> Shows good resistance to abrasives. Has poor resistance to most solvents and oils.  | 150°F<br>66°C  | 32°F<br>0°C    |
| <b>Virgin PTFE:</b> (PFA/TFE) Chemically inert, virtually impervious. Very few chemicals are known to chemically react with PTFE; molten alkali metals, turbulent liquid or gaseous fluorine and a few fluoro-chemicals such as chlorine trifluoride or oxygen difluoride which readily liberate free fluorine at elevated temperatures. | 220°F<br>104°C | -35°F<br>-37°C |

Maximum and Minimum Temperatures are the limits for which these materials can be operated. Temperatures coupled with pressure affect the longevity of diaphragm pump components. Maximum life should not be expected at the extreme limits of the temperature ranges.

| Metals:   |  |
|---|--|
| <b>Alloy C:</b> Equal to ASTM494 CW-12M-1 specification for nickel and nickel alloy.  |  |
| <b>Stainless Steel:</b> Equal to or exceeding ASTM specification A743 CF-8M for corrosion resistant iron chromium, iron chromium nickel and nickel based alloy castings for general applications. Commonly referred to as 316 Stainless Steel in the pump industry. |  |

For specific applications, always consult the Chemical Resistance Chart.

# Dimensional Drawings

## GH2, Cast Iron Wetted

Dimensions are ± .13" (3mm). Figures in parenthesis = millimeters

1: PUMP SPECS

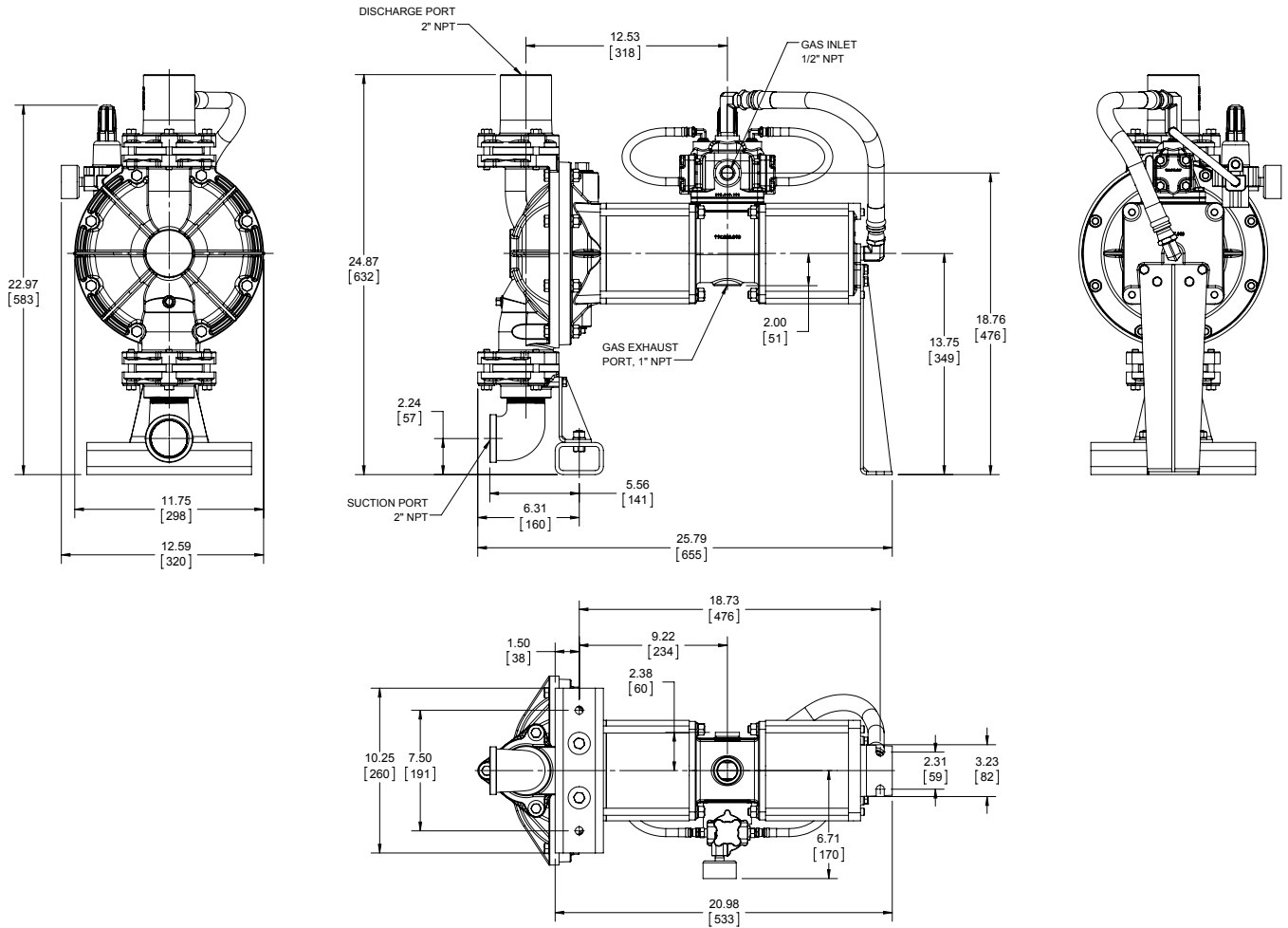

# Dimensional Drawings

## GH2, Stainless Wetted

Dimensions are ± .13" (3mm). Figures in parenthesis = millimeters

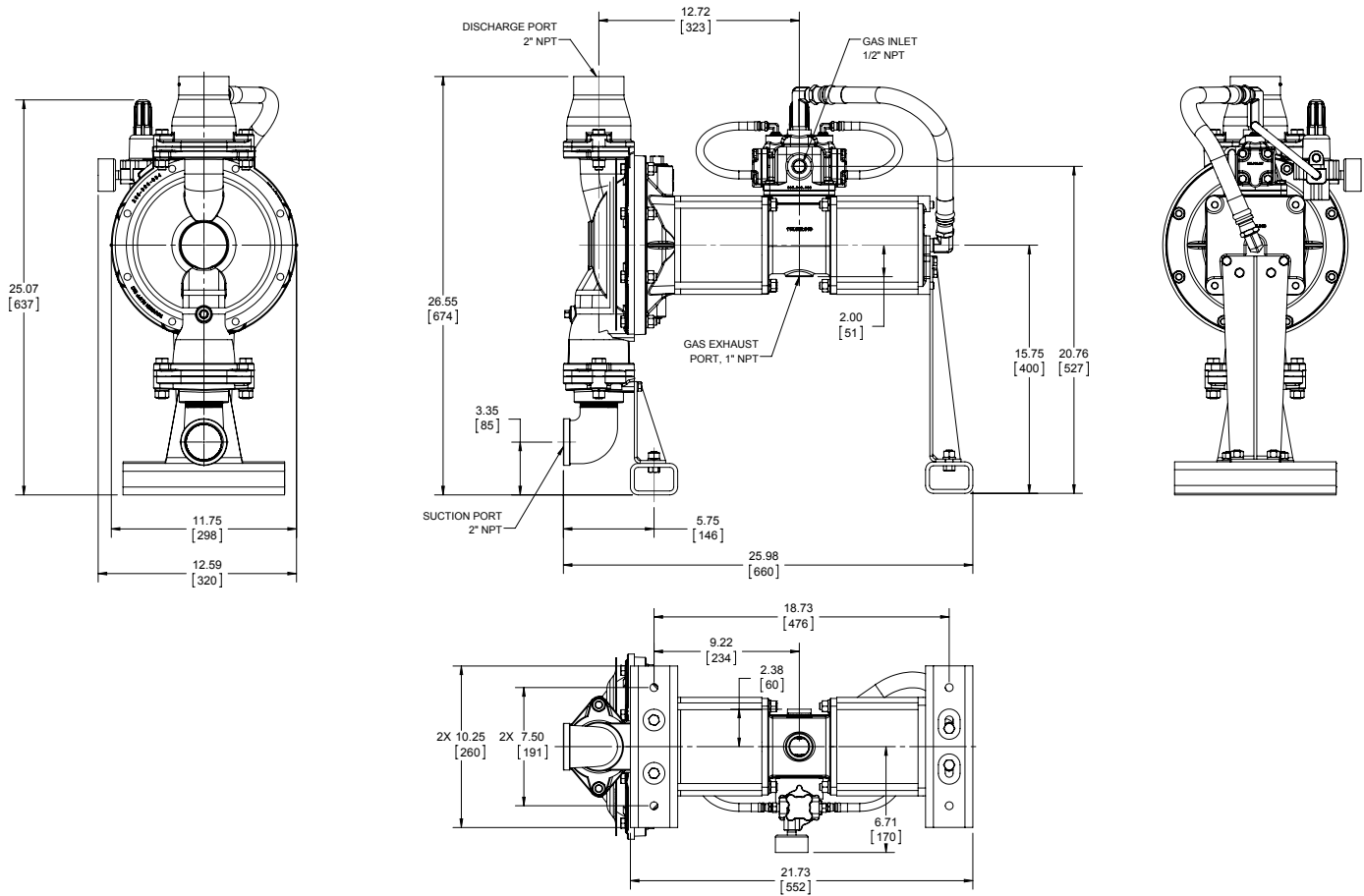

2: INSTAL & OP



# Principle of Pump Operation

## PRINCIPLE OF OPERATION

This pump is a 2:1 pressure ratio single acting pump powered by compressed gas. The 2:1 ratio is achieved by simultaneously applying gas pressure over a single end of each of two pistons connected in series by a shaft. The two pressurized ends are those most distant from the pumped fluid, with the force from the gas pressure exerted in the direction of the pumped fluid. The combined force is transferred through to the single end of the piston nearer to the pumped fluid—the single piston end having an area equal to one-half that of the two “gas” ends—and then through a fluid cell to a single pumping diaphragm.

On this single acting pump the suction stroke is independent of all discharge conditions and requires less gas pressure than the discharge stroke. The suction stroke is accomplished through a gas regulator which pressurizes the piston area in the rear cylinder adjacent to the intermediate bracket, while simultaneously exhausting the other two piston areas: one in the front cylinder, adjacent to the intermediate bracket, and the other behind the rear cylinder piston, adjacent to the cap end.

## OPERATION

The regulator is factory preset to 30 psi. After the pump is installed and in operation, the operator should raise or lower the setting until maximum performance is determined by trial and error. A setting which is too high will result in excessively rapid and noisy operation, with a loss in performance and eventually shortened pump life. The hose assemblies deliver gas to the non-wetted portions of the pump, and care should be taken that they are neither crimped nor cut.

## INSTALLATION PROCEDURES

Position the pump as close as possible to the source of the liquid to be pumped. Avoid long or undersize suction lines and use the minimum number of fittings. For permanent installation involving rigid piping, install short flexible sections of hose between the pump and piping. This reduces strains and permits easier removal of the pump for service when required.

## GAS SUPPLY

Do not connect the unit to a gas supply in excess of 125 PSI (8.61 bars). Install a shutoff valve in the gas supply line to permit removal of the unit for servicing. When connecting an gas supply of rigid piping, mount a section of flexible line to the pump to eliminate piping strain. In permanent installations, an gas-line filter is recommended.

## FREEZING OR ICING OF EXHAUST

Icing of the gas exhaust can occur under certain conditions of temperature and humidity on compressed gas power equipment. Icing is more likely to occur at high discharge pressures. Use of the Warren Rupp Air Dryer should eliminate the problem.

## MAINTENANCE AFTER USE

When the pump is used for materials that tend to settle out or transform from liquid to solid form, care must be taken after each use or during idle time to remove them and flush the pump as required to prevent damage. In freezing temperatures the pump must be completely drained when idle. This model must be tilted to allow the liquid from the chambers to run out of the discharge port.

**IMPORTANT**



Read these safety warnings and instructions in this manual completely, before installation and start-up of the pump. It is the responsibility of the purchaser to retain this manual for reference. Failure to comply with the recommendations stated in this manual will damage the pump, and void factory warranty.

**CAUTION**



Before pump operation, inspect all gasketed fasteners for looseness caused by gasket creep. Re-torque loose fasteners to prevent leakage. Follow recommended torques stated in this manual.

**WARNING**



Before maintenance or repair, shut off the compressed air line, bleed the pressure, and disconnect the air line from the pump. The discharge line may be pressurized and must be bled of its pressure.

**WARNING**



In the event of diaphragm rupture, pumped material may enter the air end of the pump, and be discharged into the atmosphere. The air exhaust must be piped to an appropriate area for safe disposition.

**WARNING**



Take action to prevent static sparking. Fire or explosion can result, especially when handling flammable liquids. The pump, piping, valves, containers or other miscellaneous equipment must be grounded.



## CHECK VALVE SERVICING

Need for inspection or service is usually indicated by poor priming, unstable cycling, reduced performance or the pump's cycling but not pumping.

## DIAPHRAGM SERVICING/FILLING DRIVER FLUID

Motive power is delivered to the single diaphragm of the pump through a fluid cell located between the diaphragm and the drive piston. During preventative maintenance servicing (where the diaphragm has not ruptured, and the fluid cell is still filled), the fluid should be drained from the chamber by removing the pipe plug, in the lower most portion of inner chamber, item 54.

To fill the fluid cell, the piston(s) must be on full discharge stroke. To do this and hold during fill procedure, remove item 46, (fitting) from the cylinder cap (item 15) and insert gas pressure. This need not be more than 10 PSI. This will move the piston(s) and hold them in the discharge position. Remove the pipe plug at the top of the fluid chamber, and fill the chamber with ethylene glycol (anti-freeze). The chamber will take 3000 ml (101.5 fluid ounces) of fluid. If the diaphragm is PTFE, use 2800 ml (95 fluid ounces). Tilt the pump to evacuate air pockets from the fluid chamber. A box wrench can be used to flex the diaphragm and purge air from the fluid chamber. Fill the chamber to the top of the fill hole, and re-insert the pipe plug, using thread compound.

If the glycol cell fluid is not compatible with the pumped product or would form a potentially dangerous mixture if the diaphragm ruptured, consult the factory before choosing an alternative fluid.

## CYLINDER PISTON SERVICING

The driver fluid must be drained (see above) to service the cylinder piston. The piston seals are different on the natural gas side versus the driver fluid side. Typically, the fluid side will require replacement before the gas side. Remove the nuts and washers that secure the gas side piston cap and inner fluid chamber to the intermediate bracket. The cylinders may now be removed. Inspect the cylinder wall carefully. Scratches can cause driver fluid to leak to the gas side of the pump, which can find its way to the exhaust muffler. Scratches on the gas cylinder will cause too much gas to leak when on pressure stroke. The locknuts holding the cylinder to the rod can now be removed. Carefully inspect the piston for scratches, burrs and wear, especially if the piston seals are worn.

The piston seals can now be inspected or replaced. **NATURAL GAS SIDE**—The gas side piston has a T-Seal. If the seal is worn showing flat areas or gouges, it will require replacement. Remove seal and back-up (spacer). Remove wear rings and carefully inspect for wear. During reassembly make sure the ends of the back up spacer and wear ring end are not across from each other. **WET SIDE**—The wet side piston has a yellow PSP seal. Inspect for flat spots and gouges. Behind the seal is an energizer ring that helps to load the seal against the cylinder wall. (The energizer ring is included with the new seal.) The wear rings are the same as on the air side. Again, make sure the ends are not across from each other.

Reassembly of both pistons is the opposite of removal. Make sure the side of the **locknut with the seal is next to the piston**. The groove in the piston or o-ring (item 35), must be toward the pump center (o-ring seals next to the rod). Apply a heavy oil to the piston seals when sliding on the cylinder. The piston/nut should be torqued at 500 in./lbs. (56.49 Newton meters). The studs that secure the cylinders to the intermediate should be torqued at 250 in./lbs. (28.24 Newton meters). **IMPORTANT NOTE:** Reassembly of the wet side piston/seal assembly differs from the gas side in that it must be carefully pressed into the cylinder. An arbor press is commonly used for this purpose.

## NATURAL GAS VALVE LUBRICATION

The SandPIPER pump's pilot valve and main gas valve assemblies are designed to operate **WITHOUT** lubrication. This is the preferred mode of operation. There may be instances of personal preference, or poor quality gas supplies when lubrication of the compressed natural gas supply is required. The pump gas system will operate with properly lubricated compressed gas supplies. Proper lubrication of the compressed gas supply would entail the use of a natural gas line lubricator set to deliver one drop of 10 wt., non-detergent oil for every 20 SCFM of gas the pump consumed at its point of operation. Consult the pump's published



**WARNING**  
Do not smoke near the pump or use the pump near an open flame. Fire or explosion could result.



**WARNING**  
This pump must not be used for fluid transfer into aircraft.



**WARNING**  
This pump is pressurized internally with natural gas pressure during operation. Always make certain that all bolting is in good condition and that all of the correct bolting is reinstalled during assembly.



**WARNING**  
When used for toxic or aggressive fluids, the pump should always be flushed clean prior to disassembly.



**WARNING**  
Before doing any maintenance on the pump, be certain all pressure is completely vented from the pump, suction, discharge, piping, and all other openings and connections. Be certain the natural gas supply is locked out or made non-operational, so that it cannot be started while work is being done on the pump. Be certain that approved eye protection and protective clothing are worn all times in the vicinity of the pump. Failure to follow these recommendations may result in serious injury or death.



**WARNING**  
Airborne particles and loud noise hazards. Wear ear and eye protection.

Pump complies with EN809 Pumping Directive, Directive 98/37/EC Safety of Machinery.

performance curve to determine this.

It is important to remember to inspect the sleeve and spool set routinely. It should move back and forth freely. This is most important when the gas supply is lubricated. If a lubricator is used, oil accumulation will, over time, collect any debris from the compressed gas. This can prevent the pump from operating properly. Water in the compressed gas supply can create problems such as icing or freezing of the exhaust gas causing the pump to cycle erratically, or stop operating. This can be addressed by using a point of use dryer to supplement a plant's gas drying equipment. This device will remove excess water from the compressed gas supply and alleviate the icing or freezing problem.

#### **ESGDS: Externally Serviceable Gas Distribution System**

Please refer to the exploded view drawing and parts list in the Service Manual supplied with your pump. If you need replacement or additional copies, contact your local Warren Rupp Distributor, or the Warren Rupp factory Literature Department. To receive the correct manual, you must specify the MODEL and TYPE information found on the name plate of the pump.

#### **Main Natural Gas Valve**

The main natural gas valve sleeve and spool set is located in the valve body mounted on the pump with four hex head capscrews. The valve body assembly is removed from the pump by removing these four hex head capscrews.

With the valve body assembly off the pump, access to the sleeve and spool set is made by removing four hex head capscrews (each end) on the end caps of the valve body assembly. With the end caps removed, slide the spool back and forth in the sleeve. The spool is closely sized to the sleeve and must move freely to allow for proper pump operation. An accumulation of oil, dirt or other contaminants from the pump's gas supply, or from a failed diaphragm, may prevent the spool from moving freely. This can cause the spool to stick in a position that prevents the pump from operating. If this is the case, the sleeve and spool set should be removed from the valve body for cleaning and further inspection. Remove the spool from the sleeve. Using an arbor press or bench vise (with an improvised mandrel), press the sleeve from the valve body. Take care not to damage the sleeve. At this point, inspect the o-rings on the sleeve for nicks, tears or abrasions. Damage of this sort could happen during assembly or servicing. A sheared or cut o-ring can allow the pump's compressed gas supply to leak or bypass within the valve assembly, causing the pump to leak compressed gas from the pump exhaust or not cycle properly. This is most noticeable at pump dead head or high discharge pressure conditions. Replace any of these o-rings as required or set up a routine, preventive maintenance schedule to do so on a regular basis. This practice should include cleaning the spool and sleeve components with a safety solvent or equivalent, inspecting for signs of wear or damage, and replacing worn components. To re-install the sleeve and spool set, lightly lubricate the o-rings on the sleeve with an o-ring assembly lubricant or lightweight oil (such as 10 wt. gas line lubricant). Press the set into the valve body easily, without shearing the o-rings. Re-install one end cap, gasket and bumper on the valve body. Using the arbor press or bench vise that was used in disassembly, press the sleeve back into the valve body. You may have to clean the surfaces of the valve body where the end caps mount. Material may remain from the old gasket. Old material not cleaned from this area may cause air leakage after reassembly. Take care that the bumper stays in place allowing the sleeve to press in all the way. Reinstall the spool, the opposite end cap, gasket and bumper on the valve body. After inspecting and cleaning the gasket surfaces on the valve body and intermediate, reinstall the valve body on the pump using new gaskets. Tighten the four hex head capscrews evenly and in an alternating cross pattern.

#### **PILOT VALVE ACTUATOR SERVICING**

The bushings for the pilot valve actuators are threaded into the intermediate bracket from the outside. The plunger may be removed for inspection or

replacement from the inside by removing the natural gas distribution valve body and the pilot valve body from the pump. The plungers should be visible as you look into the intermediate from the top. Depending on their position, you may find it necessary to use a fine piece of wire to pull them out.

Under rare circumstances, it may become necessary to replace the o-ring seal. The bushing can be pushed through the inner chamber by removing the outer chamber the assembly to reach the bushing.

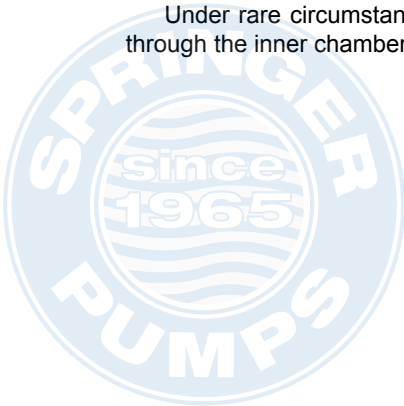

# Troubleshooting Guide

## TROUBLE SHOOTING

### 1. Pump will not cycle

- A. Check to make sure the unit has enough pressure to operate and that the gas inlet valve is open.
- B. Check the discharge line to insure that the discharge line is neither closed nor blocked.
- C. If the spool in the gas distribution valve is not shifting check the main spool. It must slide freely.
- D. Excessive gas leakage in the pump can prevent cycling. Gas leakage from the exhaust port indicates leakage in the gas distribution valve. See further service instructions.
- E. Blockage in the liquid chamber can impede movement of diaphragm.

### 2. Pump cycles but will not pump

- A. Suction side of pump pulling in gas. Check the suction line for air leaks and be sure that the end of the suction line is submerged. Check flange bolting. Check valve flanges and manifolds to chamber flange joints.
- B. Make certain the suction line or strainer is not plugged. Restriction at the suction is indicated by a high vacuum reading when a vacuum gauge is installed in the suction line.
- C. Check valves may not be seating properly. To check, remove the suction line and cover the suction port with your hand. If the unit does not pull a good suction (vacuum), the check valves should be inspected for proper seating.
- D. Static suction lift may be too high. Priming can be improved by elevating the suction and discharge lines higher than the check valves and pouring liquid into the unit through the suction inlet. When priming at high suction lifts or with long suction lines operate the pump at maximum cycle rate.

### 3. Low performance

- A. Capacity is reduced as the discharge pressure increases. Performance capability varies with available inlet supply. Check air pressure at the pump inlet when the pump is operating to make certain that adequate gas supply is maintained.
- B. Check vacuum at the pump suction. Capacity is reduced as vacuum increases. Reduced flow rate due to starved suction will be evident when cycle rate can be varied without change in capacity. This condition will be more prevalent when pumping viscous liquids. When pumping thick, heavy material the suction line must be kept as large in diameter and as short as possible, to keep suction loss minimal.
- C. Low flow rate and slow cycling rate indicate restricted flow through the discharge line. Low flow rate and fast cycling rate indicate restriction in the suction line or air leakage into suction. For more information, refer to the Warren Rupp Troubleshooting Guide.

**WARRANTY:** This unit is guaranteed for a period of five years against defective material and workmanship.



# Composite Repair Parts Drawing-Cast Iron

PTFE DIAPHRAGM ASSEMBLY

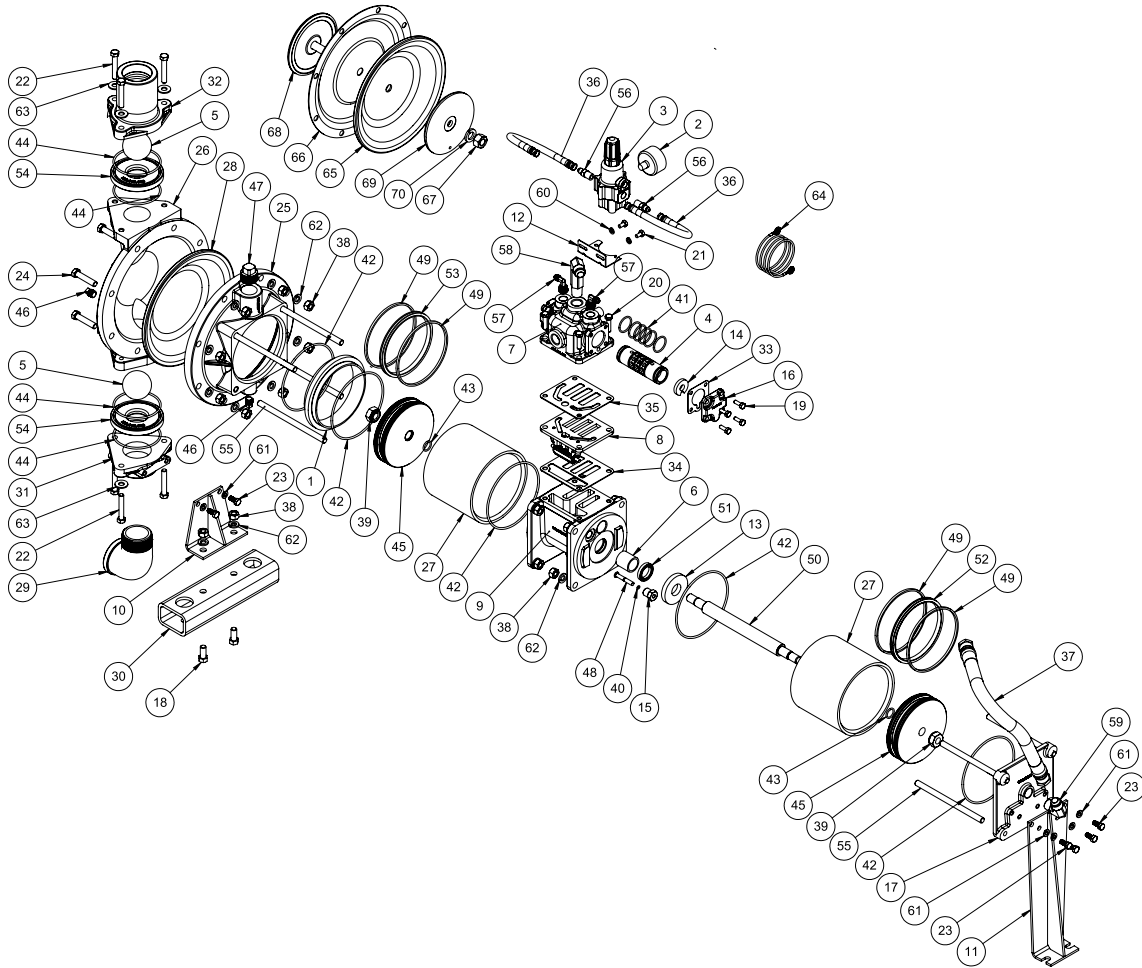

3: EXP VIEW

## Service & Repair Kits-Cast Iron Wetted

- 476.242.000 Air End Kit**  
Sleeve and Spool Set, O-rings, Bumpers, U-Cup Seals, and Gaskets, and pilot valve assembly
- 476.048.360 Wet End Kit**  
Buna diaphragm, Buna check balls, Buna o-rings and carbon steel seats
- 476.048.633 Wet End Kit**  
FKM diaphragm, FKM check balls, PTFE o-rings and carbon steel seats
- 476.048.649 Wet End Kit**  
Buna Backup Diaphragm, PTFE Overlay Diaphragm and O-Rings, Carbon Steel Seats

# Composite Repair Parts List-Cast Iron Wetted

| Item | Part Number   | Description                                | Qty. |    |             |  |    |
|------|---------------|--|------|----|-------------|--|----|
| 1    | 008.130.080   | Adapter                                    | 1    | 49 | 677.001.542 | Ring, Wear                             | 4  |
| 2    | 020.054.000   | Gauge, Pressure (Included with item #3)    | 1    | 50 | 685.043.120 | Rod, Connecting                        | 1  |
| 3    | 020.056.000   | Regulator (Includes Item #2)               | 1    | 51 | 720.004.377 | Seal, U-Cup HNBR                       | 2  |
| 4    | 031.012.000   | Sleeve and Spool Set                       | 1    | 52 | 720.022.360 | Seal, T Assembly with Backup Rings     | 1  |
| 5    | 050.005.360 W | Ball, Check - Buna (Cast Iron Wetted)      | 2    | 53 | 720.034.000 | Seal, PSP Assembly with Energizer Ring | 1  |
|      | 050.005.363 W | Ball, Check - FKM (Cast Iron Wetted)       | 2    | 54 | 722.042.080 | Seat, Check Valve (Cast Iron Wetted)   | 2  |
|      | 050.010.600   | Ball, Check - PTFE (Cast Iron Wetted)      | 2    | 55 | 807.047.080 | Stud                                   | 8  |
| 6    | 070.006.571   | Bearing, Sleeve (Included with item #9)    | 2    | 56 | 866.073.330 | Connector, Male                        | 2  |
| 7    | 095.040.156   | Body, Valve                                | 1    | 57 | 866.074.330 | Fitting, Male 90° Elbow                | 2  |
| 8    | 095.115.001   | Pilot Valve Assy                           | 1    | 58 | 866.075.330 | Fitting, Male 90° Elbow                | 1  |
| 9    | 114.027.010   | Intermediate (Includes item #6)            | 1    | 59 | 866.076.330 | Fitting, Male 90° Elbow                | 1  |
| 10   | 115.064.080   | Bracket, Mounting                          | 1    | 60 | 900.001.330 | Washer, Lock 1/4"                      | 2  |
| 11   | 115.067.080   | Bracket, Mounting                          | 1    | 61 | 900.003.330 | Washer, Lock 1/2"                      | 4  |
| 12   | 115.164.000   | Bracket, Mounting Gas Regulator            | 1    | 62 | 900.004.330 | Washer, Lock 5/16"                     | 6  |
| 13   | 132.002.360   | Bumper, Diaphragm                          | 2    | 63 | 900.006.330 | Washer, Lock 7/16" (Stainless Wetted)  | 20 |
| 14   | 132.014.358   | Bumper, Air Valve                          | 2    | 64 | 920.025.000 | Strap, Ground                          | 1  |
| 15   | 135.016.506   | Bushing, Threaded                          | 2    |    |             |  |    |
| 16   | 165.011.157   | Cap, End                                   | 2    |    |             |  |    |
| 17   | 165.047.010   | Cap, Cylinder                              | 1    |    |             |  |    |
| 18   | 170.024.330   | Capscrew, Hex-Hd 7/16-14 x 1               | 2    |    |             |  |    |
| 19   | 170.032.330   | Capscrew, Hx-Hd 1/4-20 x 3/4               | 8    |    |             |  |    |
| 20   | 170.045.330   | Capscrew, Hx-Hd 5/16-18 x 1.25             | 4    |    |             |  |    |
| 21   | 170.050.330   | Capscrew, Hx-Hd 1/4-20 x 1/2               | 2    |    |             |  |    |
| 22   | 170.052.330   | Capscrew, Hx-Hd 3/8-16 x 2.25              | 6    |    |             |  |    |
| 23   | 170.057.330   | Capscrew, Hx-Hd 5/16-18 X .75              | 6    |    |             |  |    |
| 24   | 170.060.330   | Capscrew, Hx-Hd 7/16-14 x 2.00             | 8    |    |             |  |    |
| 25   | 196.029.015   | Chamber, Inner (Includes item #46)         | 1    |    |             |  |    |
| 26   | 196.053.010   | Chamber, Outer (Includes item #46)         | 1    |    |             |  |    |
| 27   | 275.009.331   | Cylinder                                   | 2    |    |             |  |    |
| 28   | 286.036.360   | Diaphragm - Buna                           | 1    |    |             |  |    |
|      | 286.036.363   | Diaphragm - FKM                            | 1    |    |             |  |    |
| 29   | 312.046.020   | Elbow, 90° Street (Cast Iron Wetted)       | 1    |    |             |  |    |
| 30   | 326.003.080   | Foot, Mounting                             | 1    |    |             |  |    |
| 31   | 334.038.010   | Flange, Discharge (Cast Iron Wetted)       | 1    |    |             |  |    |
| 32   | 334.039.010   | Flange, Suction (Cast Iron Wetted)         | 1    |    |             |  |    |
| 33   | 360.010.360   | Gasket, End Cap                            | 2    |    |             |  |    |
| 34   | 360.041.379   | Gasket, Air Valve                          | 1    |    |             |  |    |
| 35   | 360.048.425   | Gasket, Air Valve                          | 1    |    |             |  |    |
| 36   | 426.047.000 F | Hose, Assembly                             | 2    |    |             |  |    |
| 37   | 426.048.000 F | Hose, Assembly                             | 1    |    |             |  |    |
| 38   | 545.007.330   | Nut, Hex 7/16-14 (Cast Iron Wetted)        | 18   |    |             |  |    |
| 39   | 547.009.080   | Nut, Sealing                               | 2    |    |             |  |    |
| 40   | 560.001.360   | O-ring                                     | 2    |    |             |  |    |
| 41   | 560.020.360   | O-ring                                     | 6    |    |             |  |    |
| 42   | 560.022.360   | O-ring                                     | 5    |    |             |  |    |
| 43   | 560.076.360   | O-ring                                     | 2    |    |             |  |    |
| 44   | 560.079.360   | O-ring - Buna Nitrile (Cast Iron Wetted)   | 4    |    |             |  |    |
|      | 560.079.611   | O-ring - PTFE Enc (Cast Iron Wetted)       | 4    |    |             |  |    |
| 45   | 605.012.151   | Piston                                     | 2    |    |             |  |    |
| 46   | 618.003.330   | Plug, NPT 1/4" (Included with item #25,26) | 2    |    |             |  |    |
| 47   | 618.007.330   | Plug, NPT 1"                               | 1    |    |             |  |    |
| 48   | 620.011.114   | Plunger, Actuator                          | 2    |    |             |  |    |

## PTFE Diaphragm Assembly

|    |             |  |   |
|----|-------------|--|---|
| 63 | 286.005.360 | Diaphragm, Buna                        | 1 |
| 64 | 286.020.604 | Diaphragm, Overlay                     | 1 |
| 65 | 545.008.330 | Nut, Hex 5/8-11                        | 1 |
| 66 | 612.039.010 | Plate, Outer Diaphragm (Includes stud) | 1 |
| 67 | 612.047.330 | Plate, Inner Diaphragm                 | 1 |
| 68 | 900.007.330 | Washer, Lock 5/8"                      | 1 |

3: EXP VIEW

### LEGEND:

○ = Items contained within Air End Kits

□ = Items contained within Wet End Kits

\* Air End Kit only includes sleeve and spool set, not entire air valve assembly

Note: Kits contain components specific to the material codes.

# Composite Repair Parts Drawing-Stainless

PTFE DIAPHRAGM ASSEMBLY

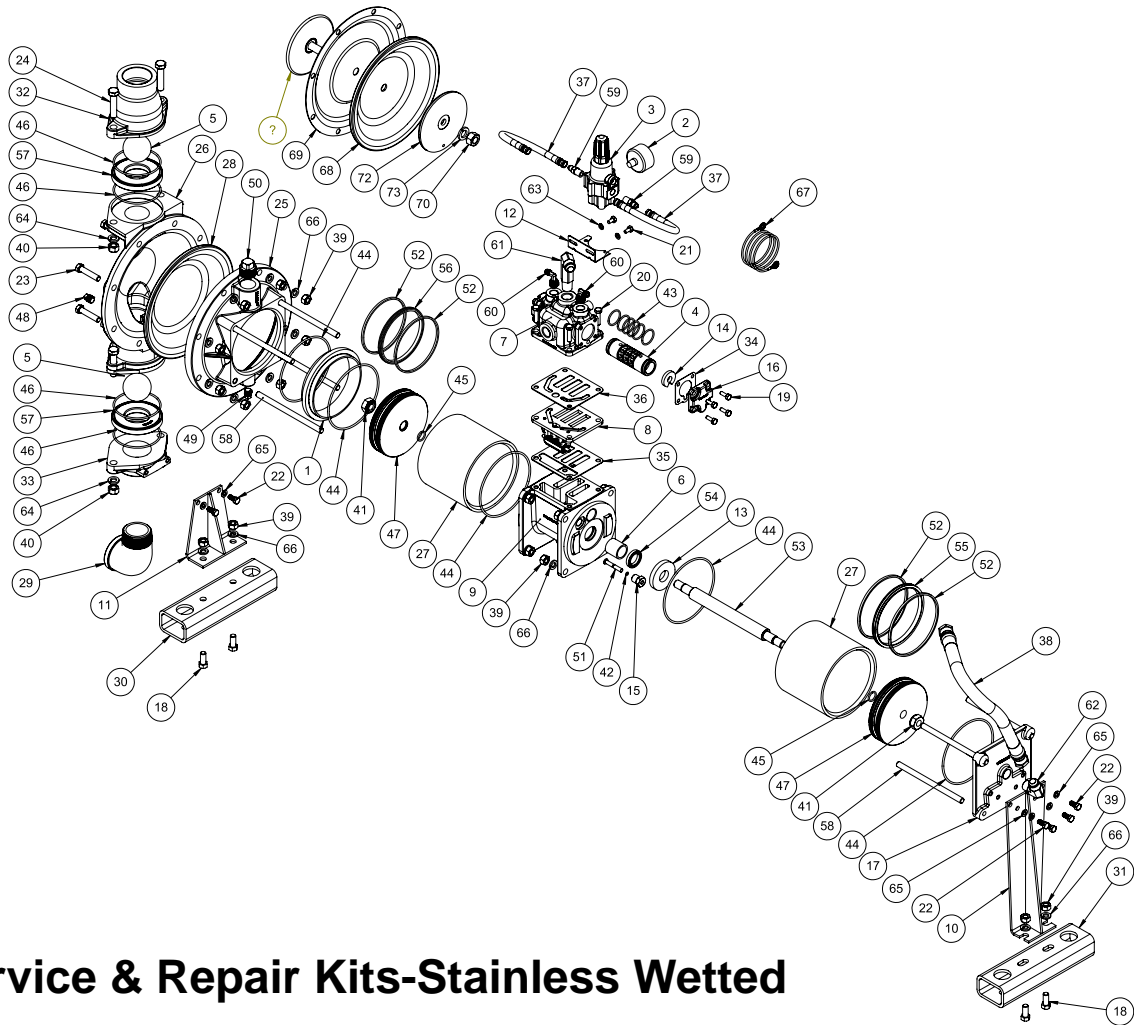

3: EXP VIEW

## Service & Repair Kits-Stainless Wetted

- 476.242.000**    **Air End Kit**  
Sleeve and Spool Set, O-rings, Bumpers, U-Cup Seals, and Gaskets, and pilot valve assembly
- 476.056.360**    **Wet End Kit**  
Buna diaphragm, Buna check balls, Buna o-rings and stainless steel seats
- 476.056.633**    **Wet End Kit**  
FKM diaphragm, FKM check balls, PTFE o-rings and carbon steel seats
- 476.056.649**    **Wet End Kit**  
Buna backup diaphragm, PTFE Overlay, PTFE check balls, PTFE seals and stainless steel seats



# Composite Repair Parts List-Stainless

| Item                    | Part Number   | Description                             | Qty. |
|-------------------------|---------------|---|------|
| 1                       | 008.013.080   | Adapter                                 | 1    |
| 2                       | 020.054.000   | Gauge, Pressure (Included with item #3) | 1    |
| 3                       | 020.056.000   | Regulator (Includes Item #2)            | 1    |
| ④                       | 031.012.000   | Sleeve and Spool Set                    | 1    |
| ⑤                       | 050.018.600   | Ball, Check - PTFE (Stainless Wetted)   | 2    |
| 6                       | 070.006.571   | Bearing, Sleeve (Included with item #9) | 2    |
| 7                       | 095.040.156   | Body, Valve                             | 1    |
| ⑧                       | 095.115.001   | Pilot Valve Assy                        | 1    |
| 9                       | 114.027.010   | Intermediate (Includes item #6)         | 1    |
| 10                      | 115.067.080   | Bracket, Mounting                       | 1    |
| 11                      | 115.172.000   | Bracket, Mounting (Stainless Wetted)    | 1    |
| 12                      | 115.164.000   | Bracket, Mounting Gas Regulator         | 1    |
| 13                      | 132.002.360   | Bumper, Diaphragm                       | 2    |
| ⑭                       | 132.014.358   | Bumper, Air Valve                       | 2    |
| ⑮                       | 135.016.506   | Bushing, Threaded                       | 2    |
| 16                      | 165.011.157   | Cap, End                                | 2    |
| 17                      | 165.047.010   | Cap, Cylinder                           | 1    |
| 18                      | 170.024.330   | Capscrew, Hx-Hd 7/16-14 x 1             | 4    |
| 19                      | 170.032.330   | Capscrew, Hx-Hd 1/4-20 x 3/4            | 8    |
| 20                      | 170.045.330   | Capscrew, Hx-Hd 5/16-18 x 1.25          | 4    |
| 21                      | 170.050.330   | Capscrew, Hx-Hd 1/4-20 x 1/2            | 2    |
| 22                      | 170.057.330   | Capscrew, Hx-Hd 5/16-18 X .75           | 6    |
| 23                      | 170.060.330   | Capscrew, Hx-Hd 7/16-14 x 2.00          | 8    |
| 24                      | 170.066.330   | Capscrew, Hx-Hd 1/2-13 x 2.25           | 4    |
| 25                      | 196.029.015   | Chamber, Inner (Includes item #49)      | 1    |
| 26                      | 196.047.010   | Chamber, Outer (Includes item #48)      | 1    |
| 27                      | 275.009.331   | Cylinder                                | 2    |
| ⑳                       | 286.036.360   | Diaphragm - Buna                        | 1    |
|                         | 286.036.363   | Diaphragm - FKM                         | 1    |
| 29                      | 312.046.110   | Elbow, 90° Street (Stainless Wetted)    | 1    |
| 30                      | 326.003.080   | Foot, Mounting                          | 1    |
| 31                      | 326.006.080   | Foot, Mounting                          | 1    |
| 32                      | 334.043.110   | Flange, Discharge (Stainless Wetted)    | 1    |
| 33                      | 334.044.110   | Flange, Suction (Stainless Wetted)      | 1    |
| ⑳                       | 360.010.360   | Gasket, End Cap                         | 2    |
| ㉑                       | 360.041.379   | Gasket, Air Valve                       | 1    |
| ㉒                       | 360.048.360   | Gasket, Air Valve                       | 1    |
| 37                      | 426.047.000 F | Hose, Assembly                          | 2    |
| 38                      | 426.048.000 F | Hose, Assembly                          | 1    |
| 39                      | 545.007.330   | Nut, Hex 7/16-14 (Stainless Wetted)     | 20   |
| 40                      | 545.008.330   | Nut, Hex 1/2-13 (Stainless Wetted)      | 4    |
| 41                      | 547.009.080   | Nut, Sealing                            | 2    |
| ㉓                       | 560.001.360   | O-ring                                  | 2    |
| ㉔                       | 560.020.360   | O-ring                                  | 6    |
| 44                      | 560.022.360   | O-ring                                  | 5    |
| 45                      | 560.076.360   | O-ring                                  | 2    |
| ㉕                       | 560.106.360   | O-ring - Buna (Stainless Wetted)        | 4    |
|                         | 560.106.363   | O-ring - FKM (Stainless Wetted)         | 4    |
|                         | 720.060.608   | Seal - PTFE (Stainless Wetted)          | 4    |
| 47                      | 605.012.151   | Piston                                  | 2    |
| 48                      | 618.003.110   | Plug, NPT 1/4" (Included with item #26) | 2    |
| 49                      | 618.003.330   | Plug, NPT 1/4" (Included with item #25) | 2    |
| 50                      | 618.007.330   | Plug, NPT 1"                            | 1    |
| ㉖                       | 620.011.114   | Plunger, Actuator                       | 2    |
| 52                      | 677.001.542   | Ring, Wear                              | 4    |
| 53                      | 685.043.120   | Rod, Connecting                         | 1    |
| ㉗                       | 720.004.377   | Seal, U-Cup HNBR                        | 2    |
| 55                      | 720.022.360   | Seal, T Assembly with Backup Rings      | 1    |
| 56                      | 720.034.000   | Seal, PSP Assembly with Energizer Ring  | 1    |
| ㉘                       | 722.040.110   | Seat, Check Valve (Stainless Wetted)    | 2    |
| 58                      | 807.047.080   | Stud                                    | 8    |
| 59                      | 866.073.330   | Connector, Male                         | 2    |
| 60                      | 866.074.330   | Fitting, Male 90° Elbow                 | 2    |
| 61                      | 866.075.330   | Fitting, Male 90° Elbow                 | 1    |
| 62                      | 866.076.330   | Fitting, Male 90° Elbow                 | 1    |
| 63                      | 900.001.330   | Washer, Lock 1/4"                       | 2    |
| 64                      | 900.003.330   | Washer, Lock 1/2"                       | 4    |
| 65                      | 900.004.330   | Washer, Lock 5/16"                      | 6    |
| 66                      | 900.006.330   | Washer, Lock 7/16" (Stainless Wetted)   | 20   |
| 67                      | 920.025.000   | Strap, Ground                           | 1    |
| PTFE Diaphragm Assembly |               |   |      |
| ㉙                       | 286.005.360   | Diaphragm, Buna                         | 1    |
|                         | 286.005.363   | Diaphragm, FKM                          | 1    |
| ㉚                       | 286.020.604   | Diaphragm, Overlay                      | 1    |
| 70                      | 545.009.330   | Nut, Hex 5/8-11                         | 1    |
| 71                      | 612.097.110   | Plate, Outer Diaphragm (Includes stud)  | 1    |
| 72                      | 612.047.330   | Plate, Inner Diaphragm                  | 1    |
| 73                      | 900.007.330   | Washer, Lock 5/8"                       | 1    |

3: EXP VIEW

## LEGEND:

- Items contained within Air End Kits
- Items contained within Wet End Kits

\* Air End Kit only includes sleeve and spool set, not entire air valve assembly

Note: Kits contain components specific to the material codes.

# Material Codes - The Last 3 Digits of Part Number

3: EXP VIEW

- 000.....Assembly, sub-assembly;  
and some purchased items
- 010.....Cast Iron
- 015.....Ductile Iron
- 020.....Ferritic Malleable Iron
- 080.....Carbon Steel, AISI B-1112
- 110.....Alloy Type 316 Stainless Steel
- 111.....Alloy Type 316 Stainless Steel  
(Electro Polished)
- 112.....Alloy C
- 113.....Alloy Type 316 Stainless Steel  
(Hand Polished)
- 114.....303 Stainless Steel
- 115.....302/304 Stainless Steel
- 117.....440-C Stainless Steel (Martensitic)
- 120.....416 Stainless Steel  
(Wrought Martensitic)
- 148.....Hardcoat Anodized Aluminum
- 150.....6061-T6 Aluminum
- 152.....2024-T4 Aluminum (2023-T351)
- 155.....356-T6 Aluminum
- 156.....356-T6 Aluminum
- 157.....Die Cast Aluminum Alloy #380
- 158.....Aluminum Alloy SR-319
- 162.....Brass, Yellow, Screw Machine Stock
- 165.....Cast Bronze, 85-5-5-5
- 166.....Bronze, SAE 660
- 170.....Bronze, Bearing Type,  
Oil Impregnated
- 180.....Copper Alloy
- 305.....Carbon Steel, Black Epoxy Coated
- 306.....Carbon Steel, Black PTFE Coated
- 307.....Aluminum, Black Epoxy Coated
- 308.....Stainless Steel, Black PTFE Coated
- 309.....Aluminum, Black PTFE Coated
- 313.....Aluminum, White Epoxy Coated
- 330.....Zinc Plated Steel
- 332.....Aluminum, Electroless Nickel Plated
- 333.....Carbon Steel, Electroless  
Nickel Plated
- 335.....Galvanized Steel
- 337.....Silver Plated Steel
- 351.....Food Grade Santoprene®
- 353.....Geolast; Color: Black
- 354.....Injection Molded #203-40  
Santoprene® Duro 40D +/-5;  
Color: RED
- 356.....Hytrel®
- 357.....Injection Molded Polyurethane
- 358.....Urethane Rubber  
(Some Applications)  
(Compression Mold)
- 359.....Urethane Rubber
- 360.....Nitrile Rubber Color coded: RED
- 363.....FKM (Fluorocarbon)  
Color coded: YELLOW
- 364.....EPDM Rubber  
Color coded: BLUE
- 365.....Neoprene Rubber  
Color coded: GREEN
- 366.....Food Grade Nitrile
- 368.....Food Grade EPDM
- 371.....Philtane (Tuftane)
- 374.....Carboxylated Nitrile
- 375.....Fluorinated Nitrile
- 378.....High Density Polypropylene
- 379.....Conductive Nitrile
- 408.....Cork and Neoprene
- 425.....Compressed Fibre
- 426.....Blue Gard
- 440.....Vegetable Fibre
- 500.....Delrin® 500
- 502.....Conductive Acetal, ESD-800
- 503.....Conductive Acetal, Glass-Filled
- 506.....Delrin® 150
- 520.....Injection Molded PVDF  
Natural color
- 540.....Nylon
- 542.....Nylon
- 544.....Nylon Injection Molded
- 550.....Polyethylene
- 551.....Glass Filled Polypropylene
- 552.....Unfilled Polypropylene
- 555.....Polyvinyl Chloride
- 556.....Black Vinyl
- 558.....Conductive HDPE
- 570.....Rulon II®
- 580.....Ryton®
- 600.....PTFE (virgin material)  
Tetrafluorocarbon (TFE)
- 603.....Blue Gylon®
- 604.....PTFE
- 606.....PTFE
- 607.....Envelon
- 608.....Conductive PTFE
- 610.....PTFE Encapsulated Silicon
- 611.....PTFE Encapsulated FKM
- 632.....Neoprene/Hytrel®
- 633.....FKM/PTFE
- 634.....EPDM/PTFE
- 635.....Neoprene/PTFE
- 637.....PTFE, FKM/PTFE
- 638.....PTFE, Hytrel®/PTFE
- 639.....Nitrile/TFE
- 643.....Santoprene®/EPDM
- 644.....Santoprene®/PTFE
- 656.....Santoprene® Diaphragm and  
Check Balls/EPDM Seats
- 661.....EPDM/Santoprene®
- 666.....FDA Nitrile Diaphragm,  
PTFE Overlay, Balls, and Seals
- 668.....PTFE, FDA Santoprene®/PTFE
- Delrin and Hytrel are registered  
tradenames of E.I. DuPont.
- Nylatron is a registered tradename  
of Polymer Corp.
- Gylon is a registered tradename  
of Garlock, Inc.
- Santoprene is a registered tradename  
of Exxon Mobil Corp.
- Rulon II is a registered tradename  
of Dixon Industries Corp.
- Ryton is a registered tradename  
of Phillips Chemical Co.
- Valox is a registered tradename  
of General Electric Co.



# 5 - YEAR Limited Product Warranty

Warren Rupp, Inc. ("Warren Rupp") warrants to the original end-use purchaser that no product sold by Warren Rupp that bears a Warren Rupp brand shall fail under normal use and service due to a defect in material or workmanship within five years from the date of shipment from Warren Rupp's factory. Warren Rupp brands include Warren Rupp®, SANDPIPER®, SANDPIPER Signature Series™, MARATHON®, Porta-Pump®, SludgeMaster™ and Tranquilizer®.

The use of non-OEM replacement parts will void (or negate) agency certifications, including CE, ATEX, CSA, 3A and EC1935 compliance (Food Contact Materials). Warren Rupp, Inc. cannot ensure nor warrant non-OEM parts to meet the stringent requirements of the certifying agencies.

~ See [sandpiperpump.com/content/warranty-certifications](http://sandpiperpump.com/content/warranty-certifications) for complete warranty, including terms and conditions, limitations and exclusions. ~

**WARREN  
RUPP, INC.**

## Declaration of Conformity

**Manufacturer: Warren Rupp, Inc., 800 N. Main Street  
Mansfield, Ohio, 44902 USA**

Certifies that Air-Operated Double Diaphragm Pump Series: HDB, HDF, M Non-Metallic, S Non-Metallic, M Metallic, S Metallic, T Series, G Series, U Series, EH and SH High Pressure, RS Series, W Series, SMA and SPA Submersibles, and Tranquilizer® Surge Suppressors comply with the European Community Directive 2006/42/EC on Machinery, according to Annex VIII. This product has used Harmonized Standard EN809:1998+A1:2009, Pumps and Pump Units for Liquids - Common Safety Requirements, to verify conformance.

  
Signature of authorized person

October 20, 2005  
Date of issue

Authorised Representative:  
IDEX Pump Technologies  
R79 Shannon Industrial Estate  
Shannon, Co. Clare, Ireland

Director of Engineering  
Title

Attn: Barry McMahon

February 27, 2017  
Date of revision

Revision Level: F



7: WARRANTY

# WARREN RUPP, INC.

## EC / EU Declaration of Conformity

The objective of the declaration described is in conformity with the relevant Union harmonisation legislation: Directive 94/9/EC (until April 19, 2016) and Directive 2014/34/EU (from April 20, 2016).

**Manufacturer:**

Warren Rupp, Inc.  
A Unit of IDEX Corporation  
800 North Main Street  
P.O. Box 1568  
Mansfield, OH 44902 USA

**Applicable Standard:**

EN13463-1: 2001  
EN13463-5: 2003  
EN60079-25: 2004

**Harmonised Standard:**

EN13463-1: 2009  
EN13463-5: 2011  
EN60079-25:2010

The harmonised standards have been compared to the applicable standards used for certification purposes and no changes in the state of the art technical knowledge apply to the listed equipment.

**AODD Pumps and Surge Suppressors**

Technical File No.: 203104000-1410/MER

**AODD (Air-Operated Double Diaphragm) Pumps**

EC Type Examination Certificate No. Pumps: KEMA 09ATEX0071 X

DEKRA Certification B.V. (0344)

Meander 1051  
6825 MJ Arnhem  
The Netherlands

**Hazardous Locations Applied:**

|                                |                 |
|--------------------------------|-----------------|
| I M1 c                         | II 1 G c T5     |
| II 2 G Ex ia c IICT5           | II 1 D c T100°C |
| II 2 D Ex c iaD 20 IP67 T100°C | II 2 G c T5     |
| II 2 G Eex m c IIT5            | II 2 D c T100°C |
| II 2 D c IP65 T100°C           | II 2 G c IIB T5 |

# SANDPIPER®

A WARREN RUPP, INC. BRAND

# Tranquilizer®

DATE/APPROVAL/TITLE:  
18 March 2016

*David Roseberry*  
David Roseberry, Director of Engineering

7: WARRANTY