

SERVICE & OPERATING MANUAL

Original Instructions

G SERIES

1: PUMP SPECS

2: INSTAL & OP

3: EXP VIEW

4: Gas END

5: WET END

6: WARRANTY

Certified Quality



ISO 9001 Certified
ISO 14001 Certified



Certified to CSA Technical Letter No. R-14



Certified to ANSI LC6-2008



Warren Rupp, Inc.
A Unit of IDEX Corporation
800 N. Main St.,
Mansfield, Ohio 44902 USA
Telephone 419.524.8388
Fax 419.522.7867
SANDPIPERPUMP.COM



© Copyright 2017 Warren Rupp, Inc.
All rights reserved

Model G30

Metallic Design Level 1

Natural Gas-Operated Diaphragm Pumps

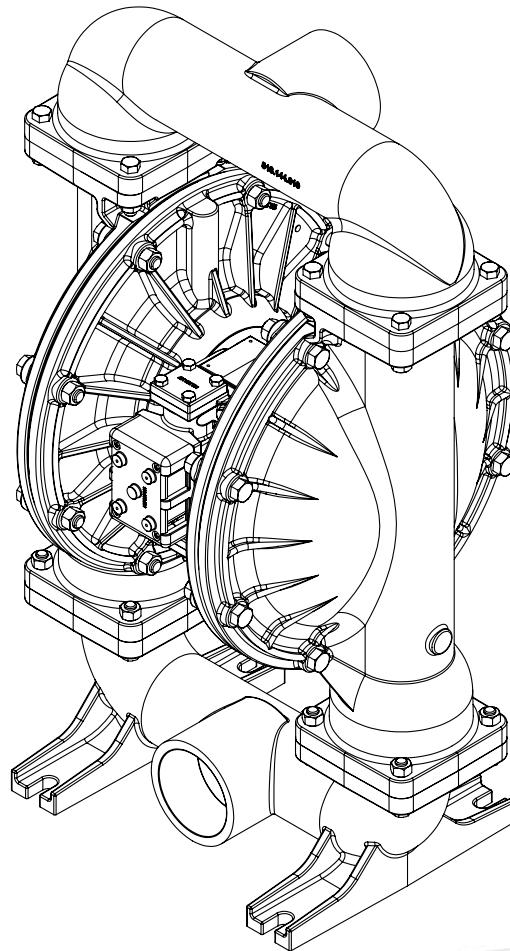

SANDPIPER®

A WARREN RUPP, INC. BRAND

SANDPIPERPUMP.COM

Safety Information

IMPORTANT



Read the safety warnings and instructions in this manual before pump installation and start-up. Failure to comply with the recommendations stated in this manual could damage the pump and void factory warranty.



When the pump is used for materials that tend to settle out or solidify, the pump should be flushed after each use to prevent damage. In freezing temperatures the pump should be completely drained between uses.

CAUTION



Before pump operation, inspect all fasteners for loosening caused by gasket creep. Retighten loose fasteners to prevent leakage. Follow recommended torques stated in this manual.



Nonmetallic pumps and plastic components are not UV stabilized. Ultraviolet radiation can damage these parts and negatively affect material properties. Do not expose to UV light for extended periods of time.



WARNING
The use of non-OEM replacement parts will void (or negate) agency certifications, including CE, ATEX, CSA, 3A and EC1935 compliance (Food Contact Materials). Warren Rupp, Inc. cannot ensure nor warrant non-OEM parts to meet the stringent requirements of the certifying agencies.

WARNING



When used for toxic or aggressive fluids, the pump should always be flushed clean prior to disassembly.



Before maintenance or repair, shut off the compressed gas line, bleed the pressure, and disconnect the gas line from the pump. Be certain that approved eye protection and protective clothing are worn at all times. Failure to follow these recommendations may result in serious injury or death.



Airborne particles and loud noise hazards. Wear eye and ear protection.



In the event of diaphragm rupture, pumped material may enter the air end of the pump, and be discharged into the atmosphere. If pumping a product that is hazardous or toxic, the air exhaust must be piped to an appropriate area for safe containment.



Take action to prevent static sparking. Fire or explosion can result, especially when handling flammable liquids. The pump, piping, valves, containers and other miscellaneous equipment must be properly grounded.



This pump is pressurized internally with gas pressure during operation. Make certain that all fasteners are in good condition and are reinstalled properly during reassembly.



Use safe practices when lifting

Grounding ATEX Pumps

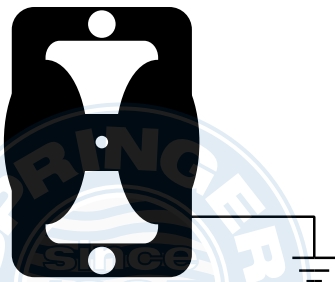

ATEX compliant pumps are suitable for use in explosive atmospheres when the equipment is properly grounded in accordance with local electrical codes. Pumps equipped with electrically conductive diaphragms are suitable for the transfer of conductive or non-conductive fluids of any explosion group. When operating pumps equipped with non-conductive diaphragms that exceed the maximum permissible projected area, as defined in EN 13463-1 2009 section 6.7.5 table 9, the following protection methods must be applied:

- Equipment is always used to transfer electrically conductive fluids or
- Explosive environment is prevented from entering the internal portions of the pump, i.e. dry running

For further guidance on ATEX applications, please consult the factory.

Table of Contents

SECTION 1: PUMP SPECIFICATIONS.....1

- Explanation of Nomenclature
- Performance
- Materials
- Dimensional Drawings

SECTION 2: INSTALLATION & OPERATION.....5

- Principle of Pump Operation
- Recommended Installation Guide
- Troubleshooting Guide

SECTION 3: EXPLODED VIEW8

- Composite Repair Parts Drawing
- Composite Repair Parts List
- Material Codes

SECTION 4: GAS END11

- Aluminum Gas Valve Assembly
- Stainless Steel Gas Valve Assembly
- Pilot Valve Assembly
- Intermediate Assembly

SECTION 5: WET END14

- Diaphragm Drawings
- Diaphragm Servicing
- Pumping Hazardous Liquids

SECTION 7: WARRANTY & CERTIFICATES17

- Warranty
- CE Declaration of Conformity - Machinery
- ATEX Declaration of Conformity



Explanation of Pump Nomenclature

1: PUMP SPECS

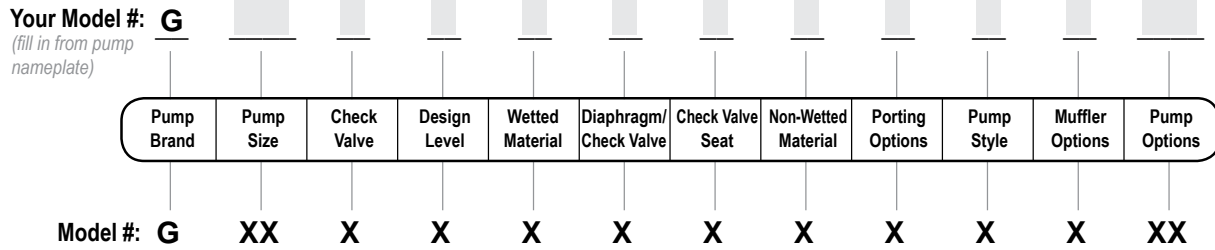

Pump Brand
G Gas Operated

Pump Size
30 3"

Check Valve Type
B Ball

Design Level
1 Design Level

Wetted Material
S Stainless Steel
A Aluminum

Diaphragm/Check Valve Materials
B Nitrile/Nitrile
T PTFE -Nitrile/PTFE

Check Valve Seat
5 Nitrile/PTFE
B Nitrile
T PTFE
A Aluminum
S Stainless Steel

Non-Wetted Material Options

- A Painted Aluminum
- B Unpainted Aluminum with Stainless Steel Gas Valve
- D Unpainted Aluminum with Stainless Steel Gas Valve with FKM O-rings
- X Unpainted Aluminum
- 0 Unpainted Aluminum/FKM Elastomers
- V Unpainted Aluminum/FKM Elastomers
- S Stainless Steel/ S02/304 SS Hardware
- T Stainless Steel/ 316 Stainless Hardware
- 7 Painted Stainless Steel
- 8 Stainless Steel/FKM Elastomers
- 9 Painted Stainless Steel/FKM Elastomers

Porting Options

- N NPT Threads
- B BSP (Tapered) Threads
- A 150# Raised Face 3" ANSI Flange (Integral Manifold)
- D 80 DIN Flange (Integral Manifold)

Pump Style
S Standard

Muffler Options
X No Muffler Permitted *

Your Serial #: (fill in from pump nameplate) _____

ATEX Detail

	ATEX Rating	Wetted Material Options	Non-Wetted Material Options
	II 1G c T5 II 1D c T100°C I M1 c I M2 c	S	S, T, 7, 8, 9
	II 2G c T5 II 2D c T100°C	All Options	All Options

Performance

G30 METALLIC

SUCTION/DISCHARGE PORT SIZE

- 3" NPT or 3" BSP Tapered
- 3" ANSI Flange or 80 DIN Flange

CAPACITY

- 0 to 285 gallons per minute (0 to 1079 liters per minute)

AIR DISTRIBUTION VALVE

- No-lube, no-stall design

SOLIDS-HANDLING

- Up to .38 in. (9.65mm)

HEADS UP TO

- 100 psi or 231 ft. of water (7 bar or 70 meters)

DISPLACEMENT/STROKE

- .94 Gallon / 3.56 liter

MAXIMUM OPERATING PRESSURE

- 100 psi (7 bar)

SHIPPING WEIGHT

- Aluminum 116 lbs. (53kg)
- Stainless Steel 194 lbs. (87kg)

These pump models are designed to pump the following fluids: Crude Oil, Salt Water, Drilling Mud, Condensate, Lubrication Oils, Glycol, Caustic Liquids, and Acids.*

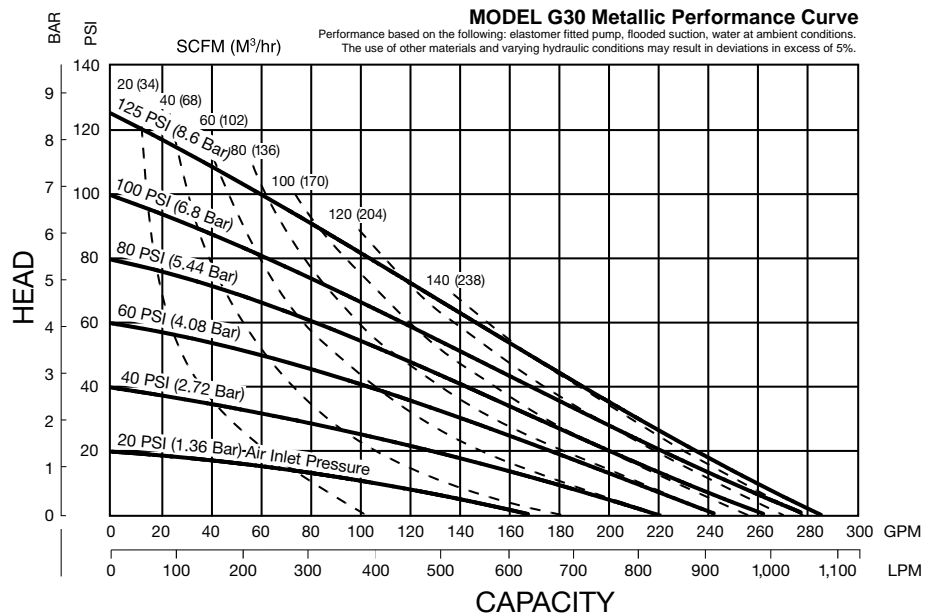

Exhaust Gas: The exhausted natural gas must be vented to a low pressure safe location in accordance with local fire safety and environmental codes, or in the absence of local codes, an industry or nationally recognized code having jurisdiction over the specific installations, and/or CAN/CGA B149, Installation Codes

Materials

Material Profile:	Operating Temperatures:	
	Max.	Min.
FKM: (Fluorocarbon) Shows good resistance to a wide range of oils and solvents; especially all aliphatic, aromatic and halogenated hydrocarbons, acids, animal and vegetable oils. Hot water or hot aqueous solutions (over 70°F(21°C)) will attack FKM.	350°F 177°C	-40°F -40°C
Nitrile: General purpose, oil-resistant. Shows good solvent, oil, water and hydraulic fluid resistance. Should not be used with highly polar solvents like acetone and MEK, ozone, chlorinated hydrocarbons and nitro hydrocarbons.	190°F 88°C	-10°F -23°C
Virgin PTFE: (PFA/TFE) Chemically inert, virtually impervious. Very few chemicals are known to chemically react with PTFE; molten alkali metals, turbulent liquid or gaseous fluorine and a few fluoro-chemicals such as chlorine trifluoride or oxygen difluoride which readily liberate free fluorine at elevated temperatures.	220°F 104°C	-35°F -37°C
<i>Maximum and Minimum Temperatures are the limits for which these materials can be operated. Temperatures coupled with pressure affect the longevity of diaphragm pump components. Maximum life should not be expected at the extreme limits of the temperature ranges.</i>		
Metals:		
Stainless Steel: Equal to or exceeding ASTM specification A743 CF-8M for corrosion resistant iron chromium, iron chromium nickel and nickel based alloy castings for general applications. Commonly referred to as 316 Stainless Steel in the pump industry.		

For specific applications, always consult the Chemical Resistance Chart.

- Ambient temperature range:** -20°C to +40°C
- Process temperature range:** -20°C to +80°C for models rated as category 1 equipment
-20°C to +100°C for models rated as category 2 equipment

In addition, the ambient temperature range and the process temperature range do not exceed the operating temperature range of the applied non-metallic parts as listed in the manuals of the pumps.

Dimensional Drawings

G30 Metallic, Flanged Ports

Dimensional Tolerance: $\pm 1/8"$ Dimensional Tolerance: $\pm 3\text{mm}$

1: PUMP SPECS

DIMENSIONAL DRAWINGS
G30 METALLIC THREADED PORTS
DIM TOL: $\pm 1/8"$ [$\pm 3\text{MM}$]

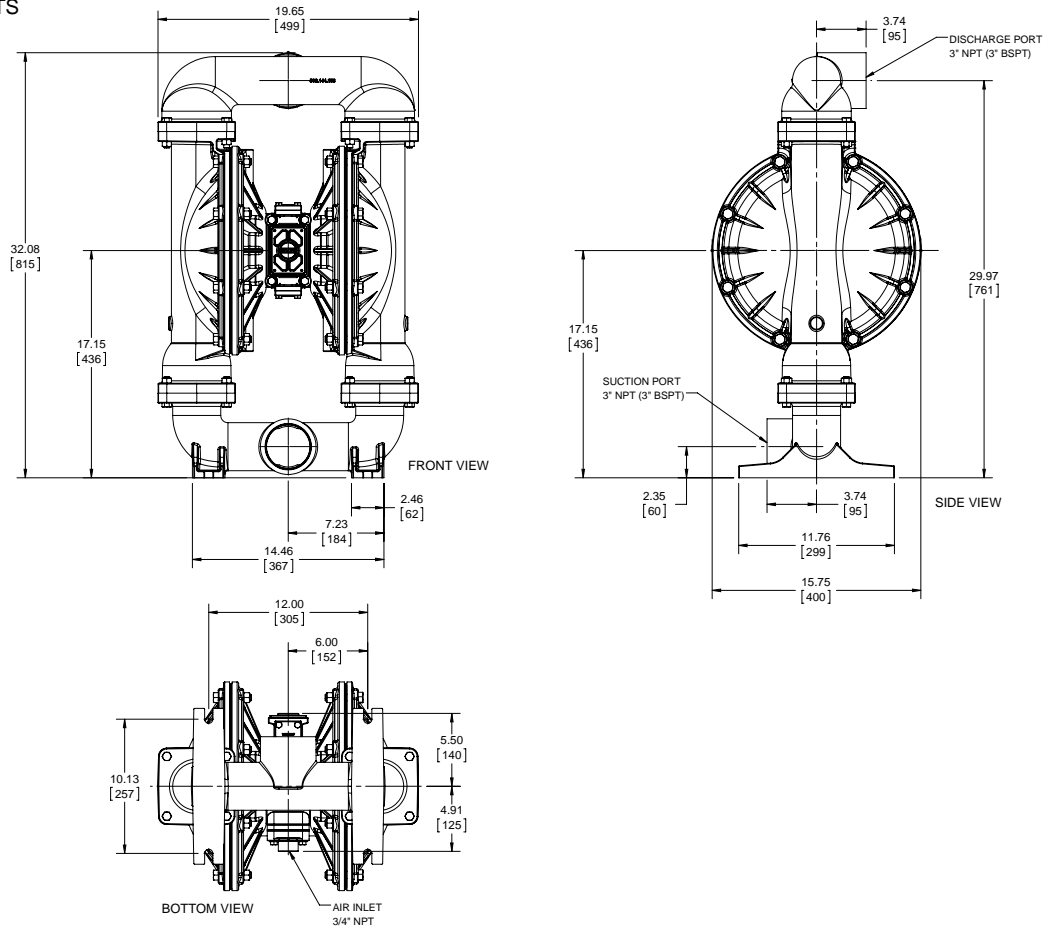

Dimensional Drawings

G30 Metallic, Threaded Ports

Dimensional Tolerance: ±1/8" Dimensional Tolerance: ± 3mm

1: PUMP SPECS

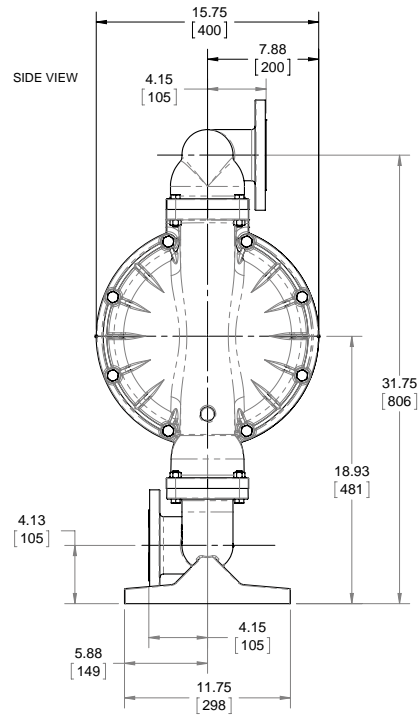
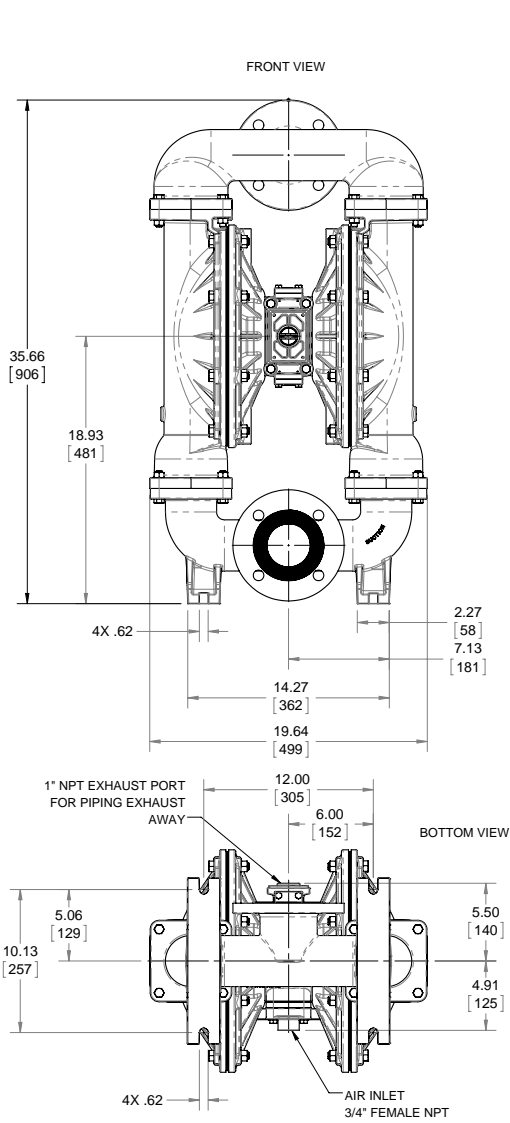

Dimension	A	B	C	D
Aluminum	29 31/32	2 11/32	17 9/64	32 1/16
Stainless Steel	30 3/16	2 9/16	17 11/32	32 9/32

Metric Dimension	A	B	C	D
Aluminum	761mm	60mm	435mm	815mm
Stainless Steel	767mm	66mm	441mm	821mm



SANDPIPERPUMP.COM

g30mdl1sm-rev0417

Model G30 Metallic • 4

Tel: 866-777-6060
Fax: 866-777-6383

Springer Pumps, LLC

Website: www.springerpumps.com
Int'l: +001 267 404 2910

Principle of Pump Operation

2: INSTAL & OP

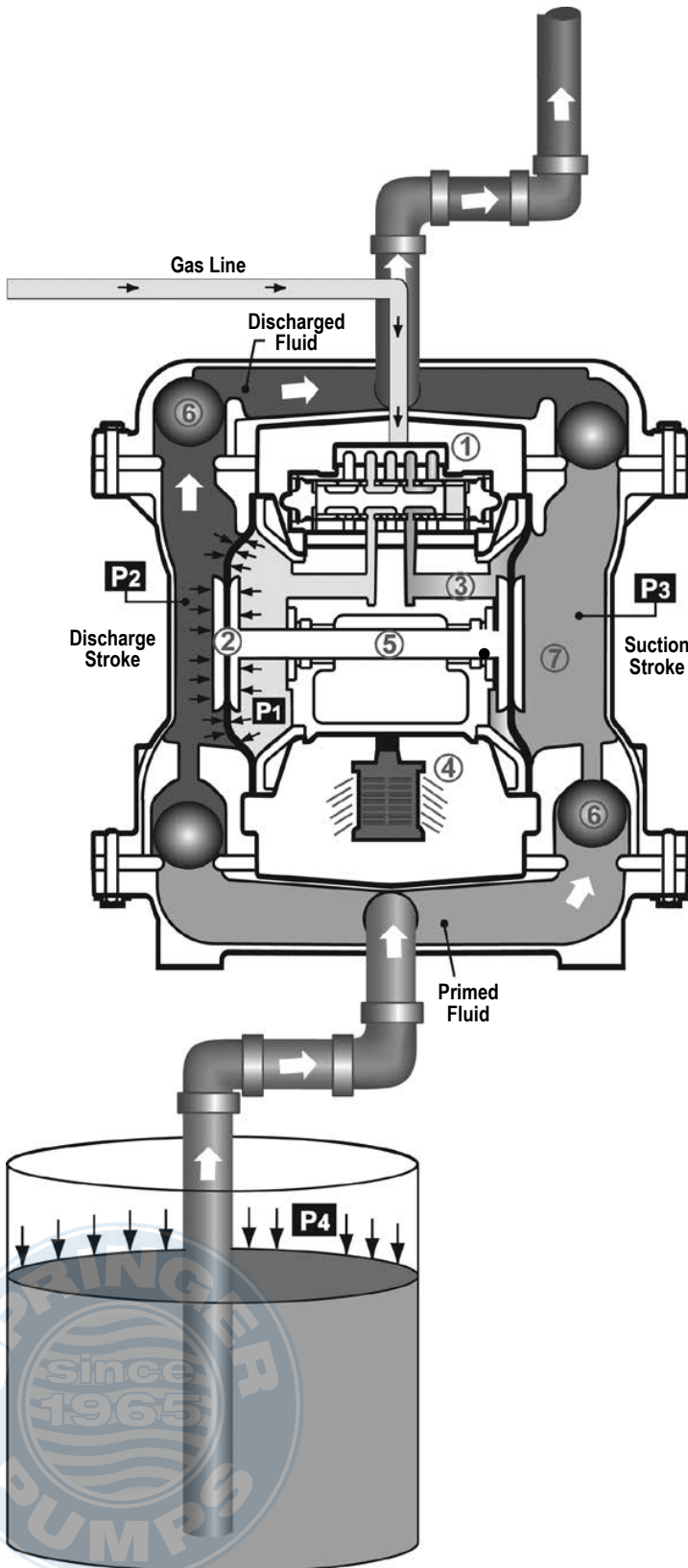

Gas-Operated Double Diaphragm pumps are powered by compressed gas, nitrogen or natural gas.

The main directional (gas) control valve ① distributes compressed gas to an gas chamber, exerting uniform pressure over the inner surface of the diaphragm ②. At the same time, the exhausting gas ③ from behind the opposite diaphragm is directed through the gas valve assembly(s) to an exhaust port ④.

As inner chamber pressure (P1) exceeds liquid chamber pressure (P2), the rod ⑤ connected diaphragms shift together creating discharge on one side and suction on the opposite side. The discharged and primed liquid's directions are controlled by the check valves (ball or flap)⑥ orientation.

The pump primes as a result of the suction stroke. The suction stroke lowers the chamber pressure (P3) increasing the chamber volume. This results in a pressure differential necessary for atmospheric pressure (P4) to push the fluid through the suction piping and across the suction side check valve and into the outer fluid chamber ⑦.

Suction (side) stroking also initiates the reciprocating (shifting, stroking or cycling) action of the pump. The suction diaphragm's movement is mechanically pulled through its stroke. The diaphragm's inner plate makes contact with an actuator plunger aligned to shift the pilot signaling valve. Once actuated, the pilot valve sends a pressure signal to the opposite end of the main directional gas valve, redirecting the compressed gas to the opposite inner chamber.

SUBMERGED ILLUSTRATION

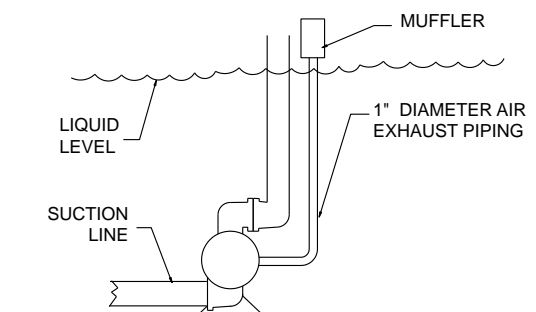

Pump can be submerged if the pump materials of construction are compatible with the liquid being pumped. The gas exhaust must be piped above the liquid level. When the pumped product source is at a higher level than the pump (flooded suction condition), pipe the exhaust higher than the product source to prevent siphoning spills.

Recommended Installation Guide

Top Discharge Ball Valve Pump

- ① **020.064.000 Filter**
VENTING WARNING: This filter is equipped with a stainless steel manual drain. The port is 1/8" NPT. When draining moisture from the filter, first shut off the natural gas supply.
- ② **020.060.000 REGULATOR WITH GAGE**
PRESSURE WARNING: This regulator is to be installed at point of use with the pump. The maximum gas supply is 400psi. Full line pressure needs to be regulated below 400psi prior to the regulator installation position.

VENTING WARNING: This regulator is equipped with a 1/4" NPT vent port. In the event of a diaphragm rupture, natural gas can be exhausted into the surrounding environment. Connect a conductive hose or pipe to the vent port to send the escaping natural gas to a safe area for gas reclamation. Make sure to ground the regulator, hose, and/or pipe.

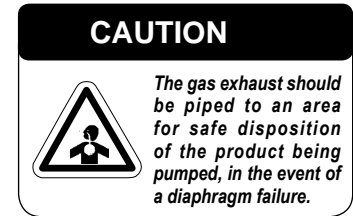

2: INSTAL & OP

Available from Warren Rupp

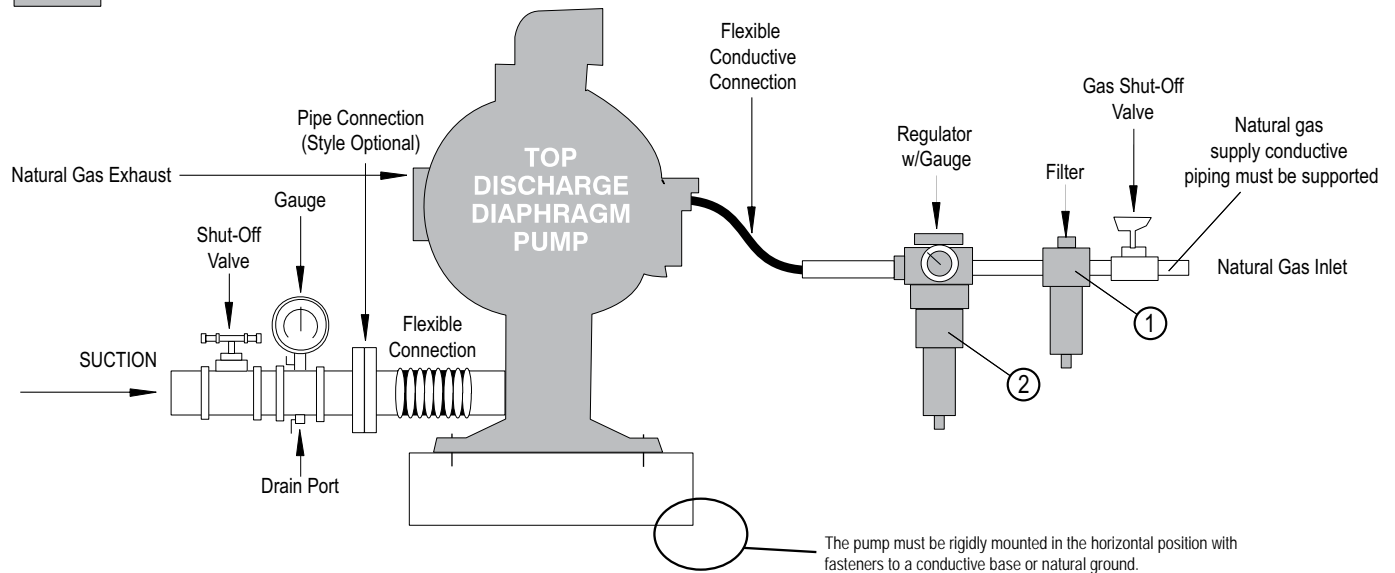

Installation And Start-Up

Locate the pump as close to the product being pumped as possible. Keep the suction line length and number of fittings to a minimum. Do not reduce the suction line diameter.

Gas Supply

Connect the pump gas inlet to an gas supply with sufficient capacity and pressure to achieve desired performance. A pressure regulating valve should be installed to insure gas supply pressure does not exceed recommended limits.

Gas Valve Lubrication

The gas distribution system is designed to operate WITHOUT lubrication. This is the standard mode of operation. If lubrication is desired, install an gas line lubricator set to deliver one drop of SAE 10 non-detergent oil for every 20 SCFM (9.4 liters/sec.) of gas the pump consumes. Consult the Performance Curve to determine gas consumption.

Gas Line Moisture

Water in the compressed gas supply may cause icing or freezing of the exhaust gas, causing the pump to cycle erratically or stop operating. Water in the gas supply can be reduced by using a point-of-use gas dryer.

Gas Inlet And Priming

To start the pump, slightly open the gas shut-off valve. After the pump primes, the gas valve can be opened to increase gas flow as desired. If opening the valve increases cycling rate, but does not increase the rate of flow, cavitation has occurred. The valve should be closed slightly to obtain the most efficient gas flow to pump flow ratio.

Troubleshooting Guide

2: INSTAL & OP

Symptom:	Potential Cause(s):	Recommendation(s):
Pump Cycles Once	Deadhead (system pressure meets or exceeds gas supply pressure).	Increase the inlet gas pressure to the pump. Pump is designed for 1:1 pressure ratio at zero flow. (Does not apply to high pressure 2:1 units).
	Gas valve or intermediate gaskets installed incorrectly.	Install gaskets with holes properly aligned.
	Bent or missing actuator plunger.	Remove pilot valve and inspect actuator plungers.
Pump Will Not Operate / Cycle	Pump is over lubricated.	Set lubricator on lowest possible setting or remove. Units are designed for lube free operation.
	Lack of gas (line size, PSI, CFM).	Check the gas line size and length, compressor capacity (HP vs. cfm required).
	Check gas distribution system.	Disassemble and inspect main gas distribution valve, pilot valve and pilot valve actuators.
	Discharge line is blocked or clogged manifolds.	Check for inadvertently closed discharge line valves. Clean discharge manifolds/piping.
	Deadhead (system pressure meets or exceeds gas supply pressure).	Increase the inlet gas pressure to the pump. Pump is designed for 1:1 pressure ratio at zero flow. (Does not apply to high pressure 2:1 units).
	Blocked gas exhaust muffler.	Remove muffler screen, clean or de-ice, and re-install.
	Pumped fluid in gas exhaust muffler.	Disassemble pump chambers. Inspect for diaphragm rupture or loose diaphragm plate assembly.
	Pump chamber is blocked.	Disassemble and inspect wetted chambers. Remove or flush any obstructions.
Pump Cycles and Will Not Prime or No Flow	Cavitation on suction side.	Check suction condition (move pump closer to product).
	Check valve obstructed. Valve ball(s) not seating properly or sticking.	Disassemble the wet end of the pump and manually dislodge obstruction in the check valve pocket. Clean out around valve ball cage and valve seat area. Replace valve ball or valve seat if damaged. Use heavier valve ball material.
	Valve ball(s) missing (pushed into chamber or manifold).	Worn valve ball or valve seat. Worn fingers in valve ball cage (replace part). Check Chemical Resistance Guide for compatibility.
	Valve ball(s) / seat(s) damaged or attacked by product.	Check Chemical Resistance Guide for compatibility.
	Check valve and/or seat is worn or needs adjusting.	Inspect check valves and seats for wear and proper setting. Replace if necessary.
	Suction line is blocked.	Remove or flush obstruction. Check and clear all suction screens or strainers.
	Excessive suction lift.	For lifts exceeding 20' of liquid, filling the chambers with liquid will prime the pump in most cases.
	Suction side gas leakage or gas in product.	Visually inspect all suction-side gaskets and pipe connections.
	Pumped fluid in gas exhaust muffler.	Disassemble pump chambers. Inspect for diaphragm rupture or loose diaphragm plate assembly.
	Pump Cycles Running Sluggish / Stalling, Flow Unsatisfactory	Over lubrication.
Icing.		Remove muffler screen, de-ice, and re-install. Install a point of use gas drier.
Clogged manifolds.		Clean manifolds to allow proper gas flow.
Deadhead (system pressure meets or exceeds gas supply pressure).		Increase the inlet gas pressure to the pump. Pump is designed for 1:1 pressure ratio at zero flow. (Does not apply to high pressure 2:1 units).
Cavitation on suction side.		Check suction (move pump closer to product).
Lack of gas (line size, PSI, CFM).		Check the gas line size, length, compressor capacity.
Excessive suction lift.		For lifts exceeding 20' of liquid, filling the chambers with liquid will prime the pump in most cases.
Gas supply pressure or volume exceeds system hd.		Decrease inlet gas (press. and vol.) to the pump. Pump is cavitating the fluid by fast cycling.
Undersized suction line.		Meet or exceed pump connections.
Restrictive or undersized gas line.		Install a larger gas line and connection.
Suction side gas leakage or gas in product.		Visually inspect all suction-side gaskets and pipe connections.
Suction line is blocked.		Remove or flush obstruction. Check and clear all suction screens or strainers.
Pumped fluid in gas exhaust muffler.		Disassemble pump chambers. Inspect for diaphragm rupture or loose diaphragm plate assembly.
Check valve obstructed.		Disassemble the wet end of the pump and manually dislodge obstruction in the check valve pocket.
Check valve and/or seat is worn or needs adjusting.		Inspect check valves and seats for wear and proper setting. Replace if necessary.
Entrained gas or vapor lock in chamber(s).		Purge chambers through tapped chamber vent plugs. Purging the chambers of gas can be dangerous.
Product Leaking Through Exhaust	Diaphragm failure, or diaphragm plates loose.	Replace diaphragms, check for damage and ensure diaphragm plates are tight.
	Diaphragm stretched around center hole or bolt holes.	Check for excessive inlet pressure or gas pressure. Consult Chemical Resistance Chart for compatibility with products, cleaners, temperature limitations and lubrication.
Premature Diaphragm Failure	Cavitation.	Enlarge pipe diameter on suction side of pump.
	Excessive flooded suction pressure.	Move pump closer to product. Raise pump/place pump on top of tank to reduce inlet pressure. Install Back pressure device (Tech bulletin 41r). Add accumulation tank or pulsation dampener.
	Misapplication (chemical/physical incompatibility).	Consult Chemical Resistance Chart for compatibility with products, cleaners, temperature limitations and lubrication.
	Incorrect diaphragm plates or plates on backwards, installed incorrectly or worn.	Check Operating Manual to check for correct part and installation. Ensure outer plates have not been worn to a sharp edge.
Unbalanced Cycling	Excessive suction lift.	For lifts exceeding 20' of liquid, filling the chambers with liquid will prime the pump in most cases.
	Undersized suction line.	Meet or exceed pump connections.
	Pumped fluid in gas exhaust muffler.	Disassemble pump chambers. Inspect for diaphragm rupture or loose diaphragm plate assembly.
	Suction side gas leakage or gas in product.	Visually inspect all suction-side gaskets and pipe connections.
	Check valve obstructed.	Disassemble the wet end of the pump and manually dislodge obstruction in the check valve pocket.
	Check valve and/or seat is worn or needs adjusting.	Inspect check valves and seats for wear and proper setting. Replace if necessary.
	Entrained gas or vapor lock in chamber(s).	Purge chambers through tapped chamber vent plugs.

For additional troubleshooting tips contact After Sales Support at service.warrenrupp@idexcorp.com or 419-524-8388

Composite Repair Parts Drawing

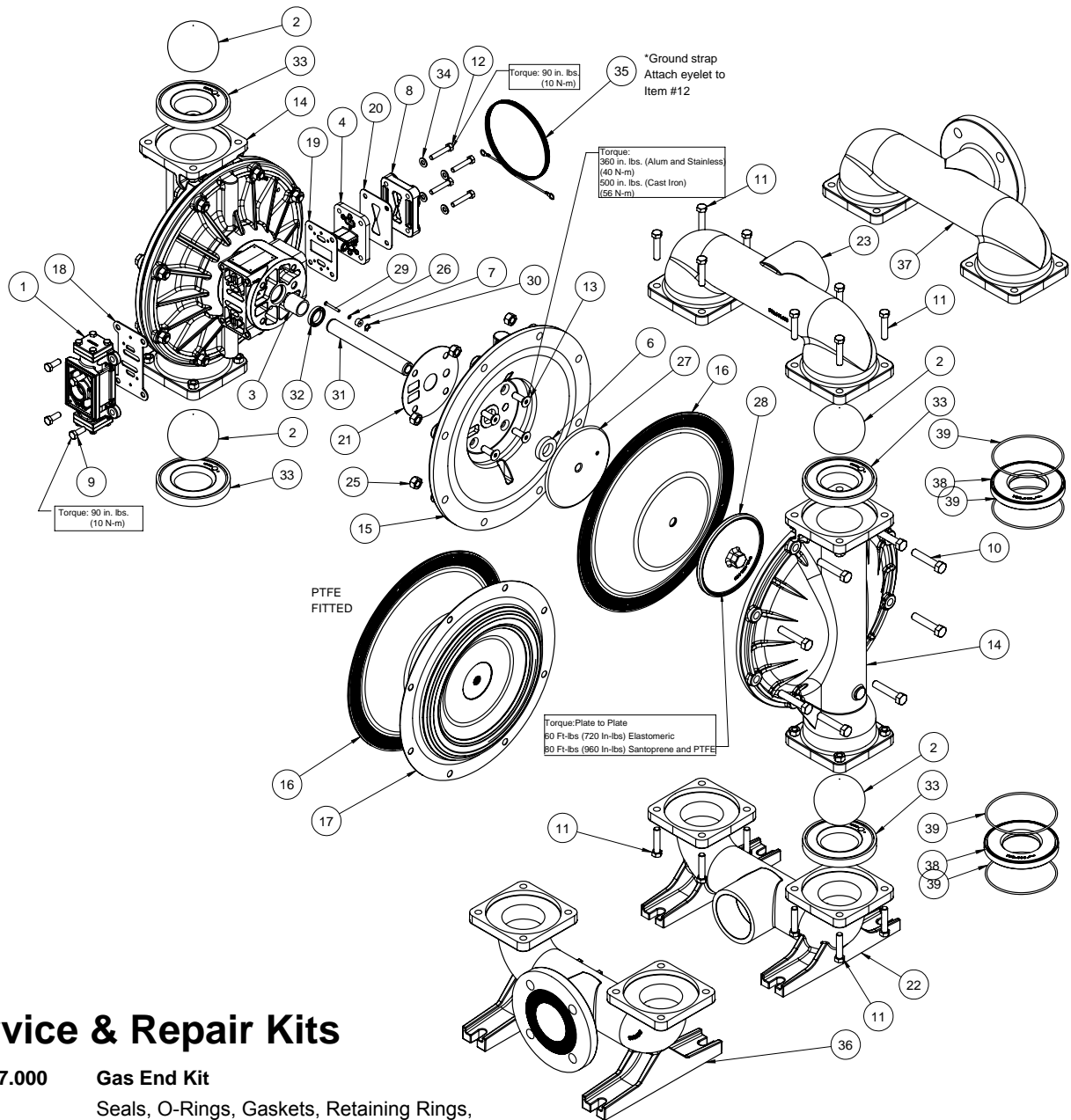

Service & Repair Kits

- 476.227.000 Gas End Kit**
Seals, O-Rings, Gaskets, Retaining Rings, Gas Valve Assembly and Pilot Valve Assembly
- 476.227.363 Gas End Kit**
FKM Seals, O-Rings, Gaskets, Retaining Rings, Gas Valve Assembly and Pilot Valve Assembly
- 476.206.360 Wetted End Kit**
Nitrile Diaphragms, Nitrile Check Balls and Nitrile Check Valve Seats
- 476.206.649 Wetted End Kit**
Nitrile Diaphragms, PTFE Overlay Diaphragms, PTFE Check Balls and PTFE Check Valve Seats
- 476.206.672 Wetted End Kit**
Nitrile Diaphragms, PTFE Check Balls, PTFE Seats

- 476.320.000 Gas End Wear Kit**
Nitrile O-rings, Bumpers, and Seals
- 476.320.363 Gas End Wear Kit**
FKM O-rings, Bumpers, and Seals
- 474.098.360 Wet End Wear Kit**
Nitrile Diaphragms
- 474.098.604 Wet End Wear Kit**
Nitrile Backer Diaphragms PTFE Overlay Diaphragms

Composite Repair Parts List

Item	Part Number	Description	Qty	Item	Part Number	Description	Qty
①	031.183.000	Air Valve Assembly	1	②1	360.105.360	Gasket, Inner Chamber	2
	031.183.363	Air Valve Assembly - FKM Elastomers	1	22	518.143.156	Manifold, Suction - NPT (w/ aluminum wetted)	1
	031.179.000	Air Valve Assembly - Stainless Center	1		518.143.110	Manifold, Suction - NPT (w/ stainless wetted)	1
	031.179.363	Air Valve Assembly - FKM Elastomers - Stainless Center	1		518.143.156E	Manifold, Suction - BSPT (w/ aluminum wetted)	1
②	050.014.360	Ball, Check - Buna	4		518.143.110E	Manifold, Suction - BSPT (w/ stainless wetted)	1
	050.015.600	Ball, Check - PTFE	4	23	518.144.156	Manifold, Discharge - NPT (w/ alum wetted)	1
3	070.006.170	Bushing, Intermediate (included in item #5)	2		518.144.110	Manifold, Discharge - NPT (w/ stainless wetted)	1
④	095.110.000	Pilot Valve Assembly	1		518.144.156E	Manifold, Discharge - BSPT (w/ alum wetted)	1
	095.110.363	Pilot Valve Assembly - FKM Elastomers	1		518.144.110E	Manifold, Discharge - BSPT (w/ stainless wetted)	1
	095.110.110	Pilot Valve Assembly - Stainless Center	1	24	545.007.330	Nut, Hex 7/16-14	16
	095.110.363SS	Pilot Valve Assembly - FKM Elastomers - Stainless Center	1		545.007.115	Nut, Hex 7/16-14 (w/ stainless hardware)	16
5	114.024.157	Intermediate (w/ aluminum center)	1		545.007.110	Nut, Hex 7/16-14 (w/ 316 stainless hardware)	16
	114.024.110	Intermediate (w/ stainless center)	1	25	545.008.330	Nut, Hex 1/2-13	16
⑥	132.035.360	Bumper, Diaphragm	2		545.008.115	Nut, Hex 1/2-13 (w/ stainless hardware)	16
	132.035.363	Bumper, Diaphragm - FKM Elastomers	2		545.008.110	Nut, Hex 1/2-13 (w/ 316 stainless hardware)	16
⑦	135.034.506	Bushing, Plunger	2	②6	560.001.360	O-ring	2
8	165.XXX.157	Cap, Air Inlet (w/ aluminum center)	1		560.001.363	O-ring - FKM Elastomers	2
	165.XXX.110	Cap, Air Inlet (w/ stainless center)	1	27	612.192.157	Plate, Inner Diaphragm (w/ aluminum center)	2
9	170.006.330	Capscrew, Hx-Hd 3/8-18 X 1.00	4		612.192.334	Plate, Inner Diaphragm (w/ stainless center)	2
	170.006.115	Capscrew, Hx-Hd 3/8-18 X 1.00 (w/ SS hardware)	4	28	612.194.157	Plate, Outer Diaphragm (w/ aluminum wetted)	2
	170.006.110	Capscrew, Hx-Hd 3/8-18 X 1.00 (w/ 316 SS hardware)	4		612.194.110	Plate, Outer Diaphragm (w/ stainless wetted)	2
10	170.055.330	Capscrew, Hx-Hd 1/2-13 X 2.50	16	②9	620.020.115	Plunger, Actuator	2
	170.055.115	Capscrew, Hx-Hd 1/2-13 X 2.50 (w/ SS hardware)	16	③0	675.042.115	Ring, Retaining	2
	170.055.110	Capscrew, Hx-Hd 1/2-13 X 2.50 (w/ 316 SS hardware)	16	31	685.040.120	Rod, Diaphragm	1
11	170.060.330	Capscrew, Hx-Hd 7/16-14 x 2.00	16	③2	720.004.360	Seal, Diaphragm Rod U-Cup	2
	170.060.115	Capscrew, Hx-Hd 7/16-14 x 2.00 (w/ SS hardware)	16		720.004.363	Seal, Diaphragm Rod U-Cup - FKM Elastomers	2
	170.060.110	Capscrew, Hx-Hd 7/16-14 x 2.00 (w/ 316 SS hardware)	16	③3	722.090.360	Seat, Check Ball - Buna	4
12	170.069.330	Capscrew, Hx-Hd 5/16-18 x 1.75	4		722.090.363	Seat, Check Ball - FKM (Viton)	4
	170.069.115	Capscrew, Hx-Hd 5/16-18 x 1.75 (w/ SS hardware)	4		722.090.600	Seat, Check Ball - PTFE	4
	170.069.110	Capscrew, Hx-Hd 5/16-18 x 1.75 (w/ 316 SS hardware)	4	34	901.038.330	Washer, Flat 5/16	4
13	171.059.330	Capscrew, Soc-Flat Hd 7/16-14 x 1.25	8		901.038.115	Washer, Flat 5/16 (w/ stainless hardware)	4
	171.059.115	Capscrew, Soc-Flat Hd 7/16-14 x 1.25 (w/ aluminum center, w/ stainless hardware)	8		901.038.110	Washer, Flat 5/16 (w/ 316 stainless hardware)	4
	171.011.115	Capscrew, Soc-Flat Hd 1/2-13 x 1.00 (w/ SS center)	8	35	920.025.000	Strap, Ground	1
	171.011.110	Capscrew, Soc-Flat Hd 1/2-13 x 1.00 (w/ SS center - 316 hw)	8	36	518.171.156	Manifold, Suction - ANSI Style Flanged (aluminum)	1
14	196.164.156	Chamber, Outer (w/ aluminum wetted)	2		518.171.110	Manifold, Suction - ANSI Style Flanged (stainless)	1
	196.164.110	Chamber, Outer (w/ stainless wetted)	2		518.171.156E	Manifold, Suction - DIN Style Flanged (aluminum)	1
15	196.165.156	Chamber, Inner (w/ aluminum center-sand cast)	2		518.171.110E	Manifold, Suction - DIN Style Flanged (stainless)	1
	196.165.157	Chamber, Inner (w/ aluminum center-die cast)	2	37	518.172.156	Manifold, Suction - ANSI Style Flanged (aluminum)	1
	196.165.110	Chamber, Inner (w/ stainless center)	2		518.171.110	Manifold, Suction - ANSI Style Flanged (stainless)	1
①6	286.098.360	Diaphragm - Buna	2		518.171.156E	Manifold, Suction - DIN Style Flanged (aluminum)	1
	286.098.363	Diaphragm - FKM	2		518.171.110E	Manifold, Suction - DIN Style Flanged (stainless)	1
①7	286.098.604	Diaphragm, Overlay - PTFE	2	38	722.090.150	Seat, Check Ball - Aluminum (requires 8 qty Item #39)	4
①8	360.093.360	Gasket, Air Valve	1		722.090.110	Seat, Check Ball - Stainless (requires 8 qty Item #39)	4
①9	360.114.360	Gasket, Pilot Valve	1	③9	560.106.360	Seal, O-ring - Buna (used with Item #38)	8
②0	360.104.379	Gasket, Air Inlet Cap	1		560.106.363	Seal, O-ring - FKM (Viton) (used with Item #38)	8
					720.060.608	Seal, PTFE (used with Item #38)	8

3: EXP VIEW

LEGEND:

○ = Items contained within Air End Kits

□ = Items contained within Wet End Kits

Note: Kits contain components specific to the material codes.



Material Codes - The Last 3 Digits of Part Number

000.....Assembly, sub-assembly; and some purchased items	364.....EPDM Rubber Color coded: BLUE
010.....Cast Iron	365.....Neoprene Rubber Color coded: GREEN
015.....Ductile Iron	366.....Food Grade Nitrile
020.....Ferritic Malleable Iron	368.....Food Grade EPDM
080.....Carbon Steel, AISI B-1112	371.....Philthane (Tuftane)
110.....Alloy Type 316 Stainless Steel	374.....Carboxylated Nitrile
111.....Alloy Type 316 Stainless Steel (Electro Polished)	375.....Fluorinated Nitrile
112.....Alloy C	378.....High Density Polypropylene
113.....Alloy Type 316 Stainless Steel (Hand Polished)	379.....Conductive Nitrile
114.....303 Stainless Steel	408.....Cork and Neoprene
115.....302/304 Stainless Steel	425.....Compressed Fibre
117.....440-C Stainless Steel (Martensitic)	426.....Blue Gard
120.....416 Stainless Steel (Wrought Martensitic)	440.....Vegetable Fibre
148.....Hardcoat Anodized Aluminum	500.....Delrin® 500
150.....6061-T6 Aluminum	502.....Conductive Acetal, ESD-800
152.....2024-T4 Aluminum (2023-T351)	503.....Conductive Acetal, Glass-Filled
155.....356-T6 Aluminum	506.....Delrin® 150
156.....356-T6 Aluminum	520.....Injection Molded PVDF Natural color
157.....Die Cast Aluminum Alloy #380	540.....Nylon
158.....Aluminum Alloy SR-319	542.....Nylon
162.....Brass, Yellow, Screw Machine Stock	544.....Nylon Injection Molded
165.....Cast Bronze, 85-5-5-5	550.....Polyethylene
166.....Bronze, SAE 660	551.....Glass Filled Polypropylene
170.....Bronze, Bearing Type, Oil Impregnated	552.....Unfilled Polypropylene
180.....Copper Alloy	555.....Polyvinyl Chloride
305.....Carbon Steel, Black Epoxy Coated	556.....Black Vinyl
306.....Carbon Steel, Black PTFE Coated	558.....Conductive HDPE
307.....Aluminum, Black Epoxy Coated	570.....Rulon II®
308.....Stainless Steel, Black PTFE Coated	580.....Ryton®
309.....Aluminum, Black PTFE Coated	600.....PTFE (virgin material) Tetrafluorocarbon (TFE)
313.....Aluminum, White Epoxy Coated	603.....Blue Gylon®
330.....Zinc Plated Steel	604.....PTFE
332.....Aluminum, Electroless Nickel Plated	606.....PTFE
333.....Carbon Steel, Electroless Nickel Plated	607.....Envelon
335.....Galvanized Steel	608.....Conductive PTFE
337.....Silver Plated Steel	610.....PTFE Encapsulated Silicon
351.....Food Grade Santoprene®	611.....PTFE Encapsulated FKM
353.....Geolast; Color: Black	632.....Neoprene/Hytrel®
354.....Injection Molded #203-40 Santoprene® Duro 40D +/-5; Color: RED	633.....FKM/PTFE
356.....Hytrel®	634.....EPDM/PTFE
357.....Injection Molded Polyurethane	635.....Neoprene/PTFE
358.....Urethane Rubber (Some Applications) (Compression Mold)	637.....PTFE, FKM/PTFE
359.....Urethane Rubber	638.....PTFE, Hytrel®/PTFE
360.....Nitrile Rubber Color coded: RED	639.....Nitrile/TFE
363.....FKM (Fluorocarbon) Color coded: YELLOW	643.....Santoprene®/EPDM
	644.....Santoprene®/PTFE
	656.....Santoprene® Diaphragm and Check Balls/EPDM Seats
	661.....EPDM/Santoprene®
	666.....FDA Nitrile Diaphragm, PTFE Overlay, Balls, and Seals
	668.....PTFE, FDA Santoprene®/PTFE

- Delrin and Hytrel are registered tradenames of E. I. DuPont.
- Nylatron is a registered tradename of Polymer Corp.
- Gylon is a registered tradename of Garlock, Inc.
- Santoprene is a registered tradename of Exxon Mobil Corp.
- Rulon II is a registered tradename of Dixon Industries Corp.
- Ryton is a registered tradename of Phillips Chemical Co.
- Valox is a registered tradename of General Electric Co.

RECYCLING

Many components of SANDPIPER® AODD pumps are made of recyclable materials. We encourage pump users to recycle worn out parts and pumps whenever possible, after any hazardous pumped fluids are thoroughly flushed.

Gas Distribution Valve Assembly

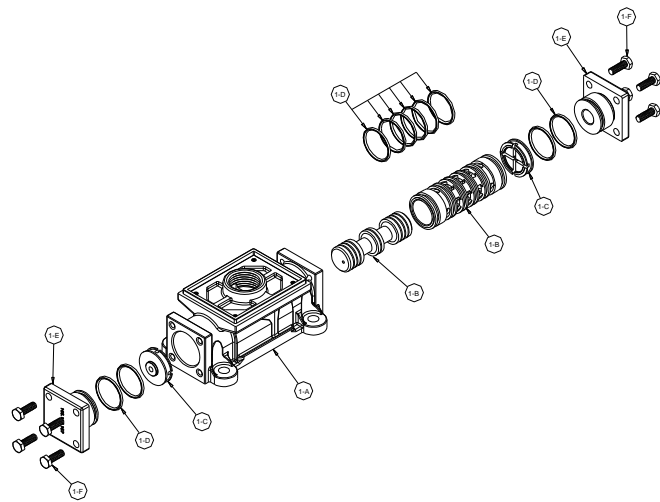

Valve Assembly for Aluminum Mid Sections

Natural Gas Assembly Parts List

Item	Part Number	Description	Qty
1	031.183.000	Gas Valve Assembly	1
1-A	095.109.157	Valve Body	1
1-B	031.139.000	Sleeve and Spool Set	1
1-C	132.029.357	Bumper	2
1-D	560.020.360	O-Ring	10
1-E	165.127.157	Cap, End	2
1-F	170.032.330	Capscrew	8

Item	Part Number	Description	Qty
1	031.183.363	Gas Valve Assembly (FKM)	1
1-D	560.020.363	O-Ring (FKM)	10

(includes all other items used on 031.183.000)

4: AIR END

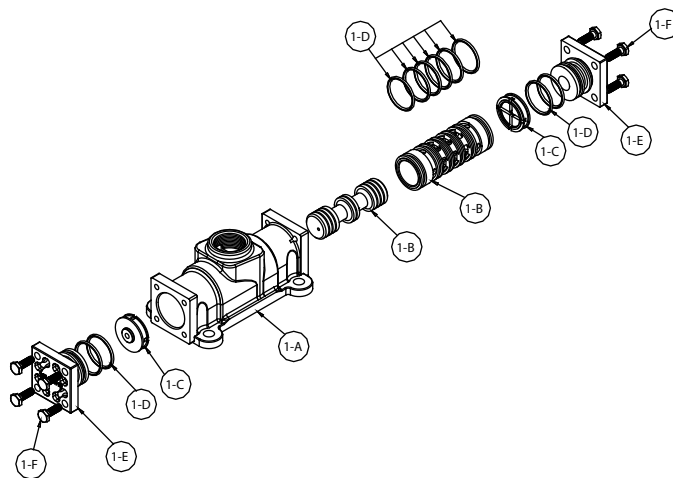

Valve Assembly for Stainless Steel Mid Sections

Natural Gas Assembly Parts List

Item	Part Number	Description	Qty
1	031.179.000	Gas Valve Assembly	1
1-A	095.109.110	Valve Body	1
1-B	031.139.000	Sleeve and Spool Set	1
1-C	132.029.357	Bumper	2
1-D	560.020.360	O-Ring	10
1-E	165.127.110	Cap, End	2
1-F	170.032.115	Capscrew	8
	170.032.110	3/16" Stainless Steel Option	8

Item	Part Number	Description	Qty
1	031.179.363	Gas Valve Assembly (FKM)	1
1-D	560.020.363	O-Ring (FKM)	10

(includes all other items used on 031.179.000)

Gas Distribution Valve Servicing

- Step 1:** Remove cap screws (1-F).
- Step 2:** Remove end cap (1-E) and bumper (1-C).
- Step 3:** Remove spool part of (1-B) (caution: do not scratch).
- Step 4:** Press sleeve (1-B) from body (1-A).
- Step 5:** Inspect O-Ring (1-D) and replace if necessary.
- Step 6:** Lightly lubricate O-Rings (1-D).
- Step 7:** Press sleeve (1-B) into body (1-A).
- Step 8:** Reassemble in reverse order, starting with step 3.

Note: Sleeve and spool (1-B) set is match ground to a specified clearance sleeve and spools (1-B) cannot be interchanged.

IMPORTANT



Read these instructions completely, before installation and start-up. It is the responsibility of the purchaser to retain this manual for reference. Failure to comply with the recommendations stated in this manual will damage the pump, and void factory warranty.



ATEX Compliant

Pilot Valve Assembly

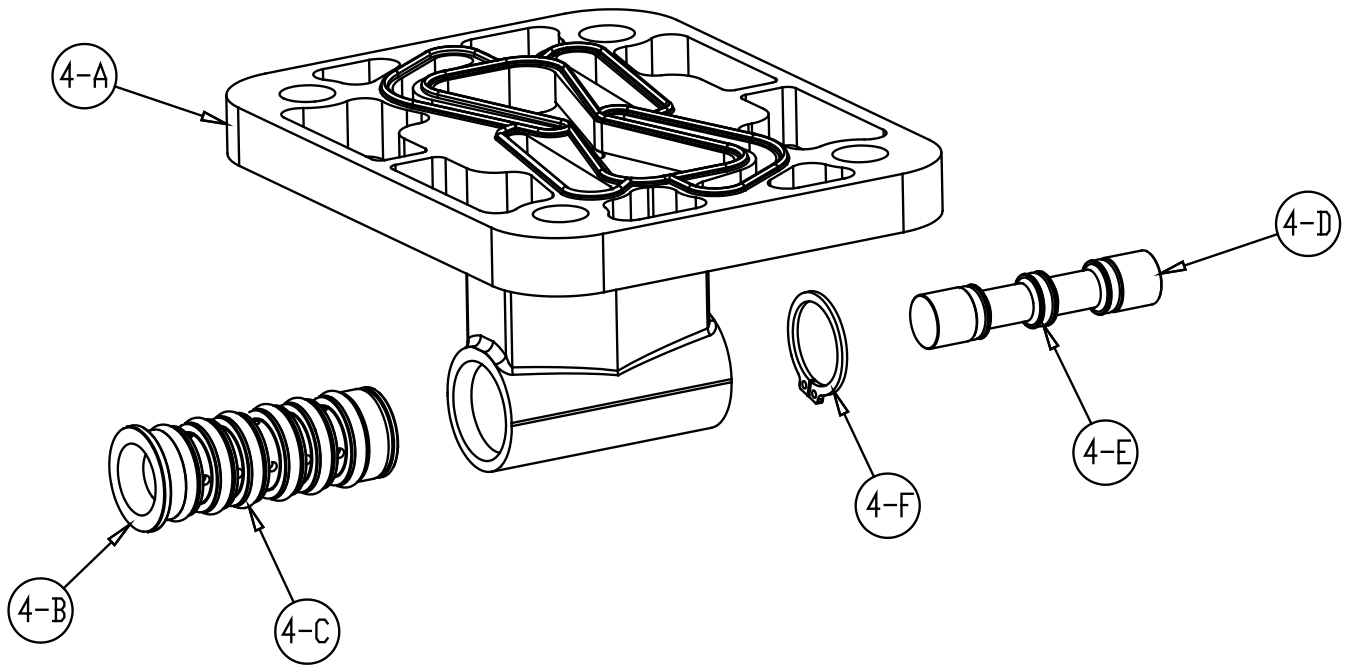

Pilot Valve Servicing

With Pilot Valve removed from pump.

Step 1: Remove snap ring (4-F).

Step 2: Remove sleeve (4-B), inspect O-Rings (4-C), replace if required.

Step 3: Remove spool (4-D) from sleeve (4-B), inspect O-Rings (4-E), replace if required.

Step 4: Lightly lubricate O-Rings (4-C) and (4-E).

Reassemble in reverse order.

Pilot Valve Assembly Parts List

Item	Part Number	Description	Qty
4	095.110.000	Pilot Valve Assembly	1
4-A	095.095.157	Valve Body	1
4-B	755.052.000	Sleeve (With O-Rings)	1
4-C	560.033.360	O-Ring (Sleeve)	6
4-D	775.055.000	Spool (With O-Rings)	1
4-E	560.023.360	O-Ring (Spool)	3
4-F	675.037.080	Retaining Ring	1

Item	Part Number	Description	Qty
4	095.110.363	Pilot Valve Assembly	1
4-A	095.095.157	Valve Body	1
4-B	755.052.363	Sleeve (With FKM O-Rings) (FKM)	1
4-C	560.033.363	O-Ring (Sleeve) (FKM)	6
4-D	775.055.363	Spool (With FKM O-Rings) (FKM)	1
4-E	560.023.363	O-Ring (Spool) (FKM)	3

(includes all other items used on 095.110.000)

For Pumps with stainless steel center section

Item	Part Number	Description	Qty
4	095.110.110	Pilot Valve Assembly	1
4-A	095.095.110	Valve Body	1

(includes all other items used on 095.110.000)

For pumps with stainless steel center section

Item	Part Number	Description	Qty
4	095.110.363SS	Pilot Valve Assembly	1
4-B	755.052.363	Sleeve (With FKM O-Rings) (FKM)	1
4-C	560.033.363	O-Ring (Sleeve) (FKM)	6
4-D	775.055.363	Spool (With FKM O-Rings) (FKM)	1
4-E	560.023.363	O-Ring (Spool) (FKM)	3

(includes all other items used on 095.110.110)



Intermediate Assembly

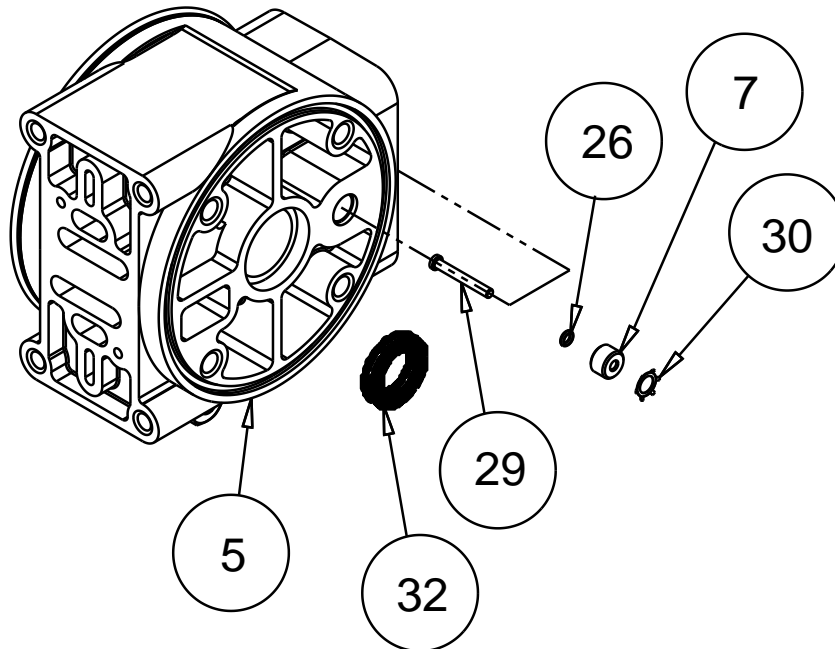

4: AIR END

Intermediate Assembly Drawing

- Step 1:** Remove plunger, actuator (29) from center of intermediate pilot valve cavity.
- Step 2:** Remove Ring, Retaining (30), discard.
- Step 3:** Remove bushing, plunger (7), inspect for wear and replace if necessary with genuine parts.
- Step 4:** Remove O-Ring (26), inspect for wear and replace if necessary with genuine parts.
- Step 5:** Lightly lubricate O-Ring (26) and insert into intermediate.
- Step 6:** Reassemble in reverse order.
- Step 7:** Remove Seal, Diaphragm Rod (32).
- Step 8:** Clean seal area, lightly lubricate and install new Seal, Diaphragm Rod (32).

INTERMEDIATE REPAIR PARTS LIST

Item	Part Number	Description	Qty
5	114.024.157	Bracket, Intermediate	1
	114.024.110	Bracket, Intermediate	1
7	135.034.506	Bushing, Plunger	2
26	560.001.360	O-Ring	2
	560.001.363	O-Ring (FKM)	2
29	620.020.115	Plunger, Actuator	2
30	675.042.115	Ring, Retaining*	2
32	720.004.360	Seal, Diaphragm Rod	2
	720.004.363	Seal, Diaphragm Rod (FKM)	2

***Note:** It is recommended that when plunger components are serviced, new retaining rings be installed.

IMPORTANT



When the pumped product source is at a higher level than the pump (flooded suction condition), pipe the exhaust higher than the product source to prevent siphoning spills. In the event of a diaphragm failure a complete rebuild of the center section is recommended.



Diaphragm Service Drawing, with Overlay

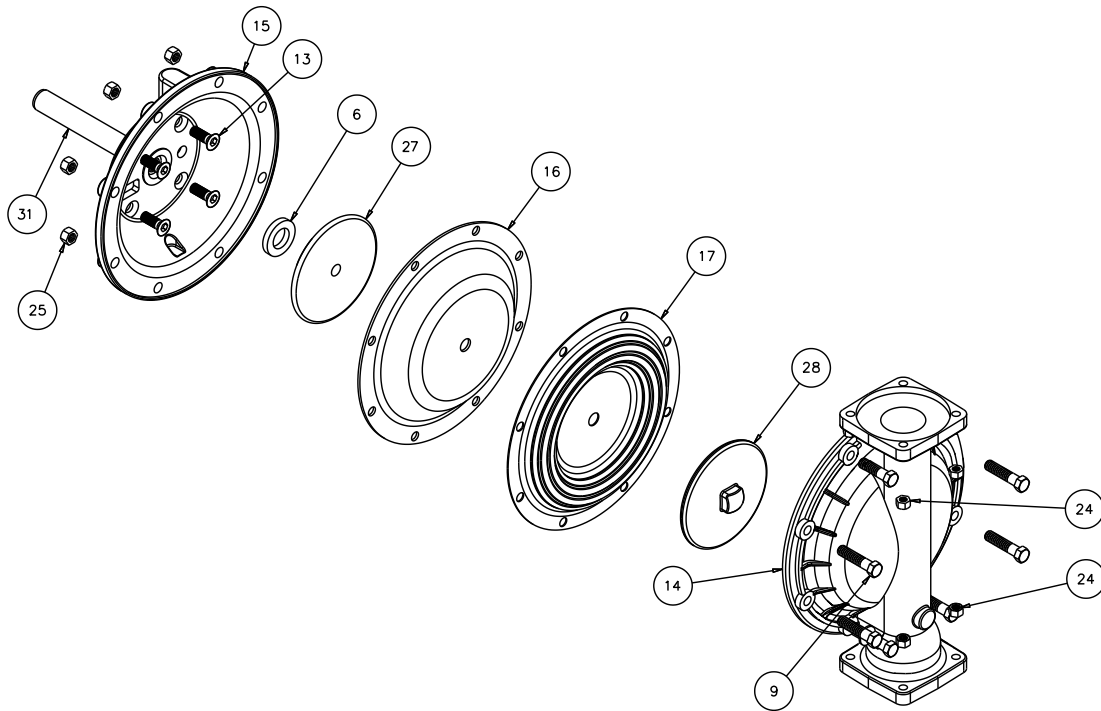

Diaphragm Service Drawing, Non-Overlay

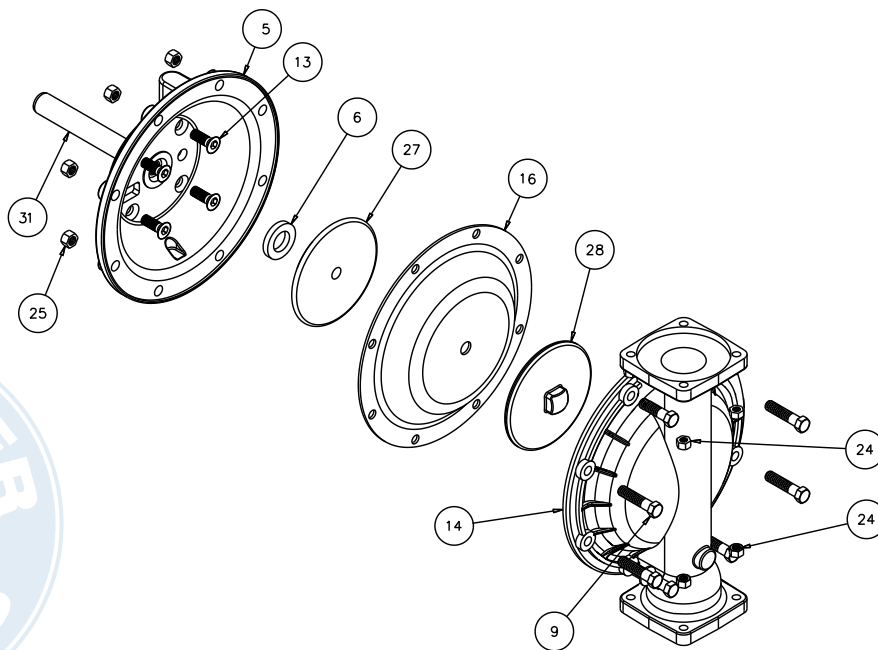

5: WET END

Diaphragm Servicing

Step 1: With manifolds and outer chambers removed, remove diaphragm assemblies from diaphragm rod. **DO NOT** use a pipe wrench or similar tool to remove assembly from rod. Flaws in the rod surface may damage bearings and seal. Soft jaws in a vise are recommended to prevent diaphragm rod damage.

Step 1.A: NOTE: Not all inner diaphragm plates are threaded. Some models utilize a through hole in the inner diaphragm plate. If required to separate diaphragm assembly, place assembly in a vise, gripping on the exterior cast diameter of the inner plate. Turn the outer plate clockwise to separate the assembly.

Always inspect diaphragms for wear cracks or chemical attack. Inspect inner and outer plates for deformities, rust scale and wear. Inspect intermediate bearings for elongation and wear. Inspect diaphragm rod for wear or marks.

Clean or repair if appropriate. Replace as required.

Step 2: Reassembly: There are two different types of diaphragm plate assemblies utilized throughout the Sandpiper product line: Outer plate with a threaded stud, diaphragm, and a threaded inner plate.

Outer plate with a threaded stud, diaphragm, and an inner plate with through hole. Secure threaded inner plate in a vise. Ensure that the plates are being installed with the outer radius against the diaphragm.

Step 3: Lightly lubricate, with a compatible material, the inner faces of both outer and inner diaphragm plates when using on non Overlay diaphragms (For EPDM water is recommended). No lubrication is required.

Step 4: Push the threaded outer diaphragm plate through the center hole of the diaphragm.

Note: Most diaphragms are installed with the natural bulge out towards the fluid side. S05, S07, and S10 non-metallic units are installed with the natural bulge in towards the gas side.

Step 5: Thread or place, outer plate stud into the inner plate. For threaded inner plates, use a torque wrench to tighten the assembly together. Torque values are called out on the exploded view.

Repeat procedure for second side assembly. Allow a minimum of 15 minutes to elapse after torquing, then re-torque the assembly to compensate for stress relaxation in the clamped assembly.

Step 6: Thread one assembly onto the diaphragm rod with sealing washer (when used) and bumper.

Step 7: Install diaphragm rod assembly into pump and secure by installing the outer chamber in place and tightening the capscrews.

Step 8: On opposite side of pump, thread the remaining assembly onto the diaphragm rod. Using a torque wrench, tighten the assembly to the diaphragm rod. Align diaphragm through bolt holes, always going forward past the recommended torque. Torque values are called out on the exploded view. **NEVER** reverse to align holes, if alignment cannot be achieved without damage to diaphragm, loosen complete assemblies, rotate diaphragm and reassemble as described above.

5: WET END



⚠ IMPORTANT



Read these instructions completely, before installation and start-up. It is the responsibility of the purchaser to retain this manual for reference. Failure to comply with the recommendations stated in this manual will damage the pump, and void factory warranty.

PUMPING HAZARDOUS LIQUIDS

When a diaphragm fails, the pumped liquid or fumes enter the natural gas end of the pump. Fumes are exhausted into the surrounding environment. When pumping hazardous or toxic materials, the exhaust gas must be piped to an appropriate area for safe disposal. See illustration #1 at right.

This pump can be submerged if the pump materials of construction are compatible with the liquid being pumped. The natural gas exhaust must be piped above the liquid level. See illustration #2 at right. Piping used for the gas exhaust must not be smaller than 1" (2.54 cm) diameter. Reducing the pipe size will restrict natural gas flow and reduce pump performance. When the pumped product source is at a higher level than the pump (flooded suction condition), pipe the exhaust gas higher than the product source to prevent siphoning spills. See illustration #3 at right.

PIPING THE NATURAL GAS EXHAUST

The following steps are necessary to pipe the exhaust gas away from the pump. The gas distribution valve assembly (item 1) has 1" NPT threads for piped exhaust.

IMPORTANT INSTALLATION NOTE: The manufacturer recommends installing a flexible conductive hose or connection between the pump and any rigid plumbing. This reduces stresses on the molded threads of the natural gas exhaust port. Failure to do so may result in damage to the natural gas distribution valve body.

Any piping or hose connected to the pump's natural gas exhaust port must be conductive and physically supported. Failure to support these connections could also result in damage to the valve body.

If a high pressure gas spike is possible through the exhaust line, a pressure regulator is required in the exhaust piping.

NATURAL GAS EXHAUST ILLUSTRATION

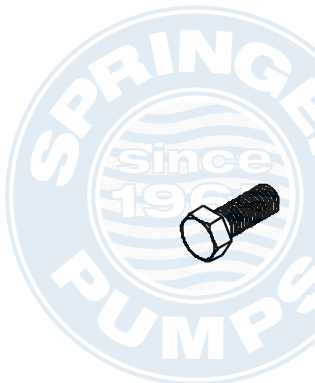
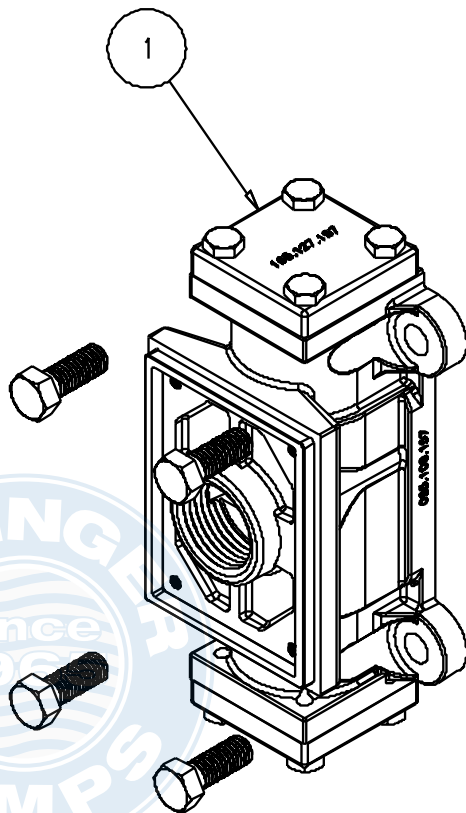
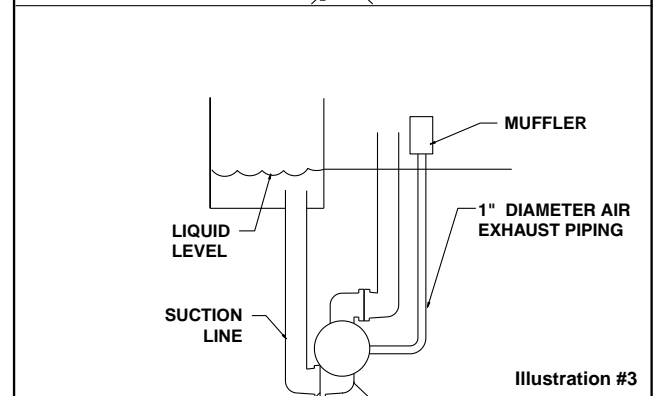
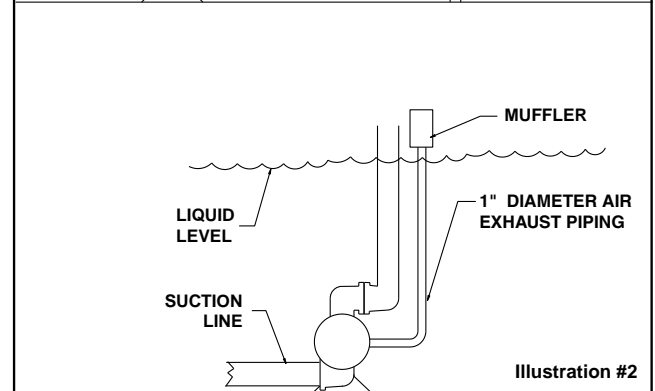
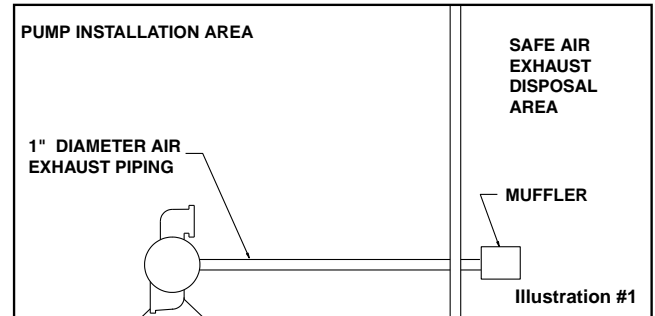

! WARNING

Natural gas exhaust is to be vented to low pressure safe location using conductive Nitrile rubber hose or metal piping in accordance with local fire and environmental codes, or an industry or nationally recognized code having jurisdiction over specific installations, and/or CAN/CGA B149, Installation Codes.

5 - YEAR Limited Product Warranty

Warren Rupp, Inc. ("Warren Rupp") warrants to the original end-use purchaser that no product sold by Warren Rupp that bears a Warren Rupp brand shall fail under normal use and service due to a defect in material or workmanship within five years from the date of shipment from Warren Rupp's factory. Warren Rupp brands include Warren Rupp®, SANDPIPER®, SANDPIPER Signature Series™, MARATHON®, Porta-Pump®, SludgeMaster™ and Tranquilizer®.

The use of non-OEM replacement parts will void (or negate) agency certifications, including CE, ATEX, CSA, 3A and EC1935 compliance (Food Contact Materials). Warren Rupp, Inc. cannot ensure nor warrant non-OEM parts to meet the stringent requirements of the certifying agencies.

~ See sandpiperpump.com/content/warranty-certifications for complete warranty, including terms and conditions, limitations and exclusions. ~

**WARREN
RUPP, INC.**

Declaration of Conformity

**Manufacturer: Warren Rupp, Inc., 800 N. Main Street
Mansfield, Ohio, 44902 USA**

Certifies that Air-Operated Double Diaphragm Pump Series: HDB, HDF, M Non-Metallic, S Non-Metallic, M Metallic, S Metallic, T Series, G Series, U Series, EH and SH High Pressure, RS Series, W Series, SMA and SPA Submersibles, and Tranquilizer® Surge Suppressors comply with the European Community Directive 2006/42/EC on Machinery, according to Annex VIII. This product has used Harmonized Standard EN809:1998+A1:2009, Pumps and Pump Units for Liquids - Common Safety Requirements, to verify conformance.

Signature of authorized person

October 20, 2005
Date of issue

Authorised Representative:
IDEX Pump Technologies
R79 Shannon Industrial Estate
Shannon, Co. Clare, Ireland

Director of Engineering
Title

Attn: Barry McMahon

February 27, 2017
Date of revision

Revision Level: F



IDEX

7: WARRANTY

WARREN RUPP, INC.

EC / EU Declaration of Conformity

The objective of the declaration described is in conformity with the relevant Union harmonisation legislation: Directive 94/9/EC (until April 19, 2016) and Directive 2014/34/EU (from April 20, 2016).

Manufacturer:

Warren Rupp, Inc.
A Unit of IDEX Corporation
800 North Main Street
P.O. Box 1568
Mansfield, OH 44902 USA

Applicable Standard:

EN13463-1: 2001
EN13463-5: 2003
EN60079-25: 2004

Harmonised Standard:

EN13463-1: 2009
EN13463-5: 2011
EN60079-25:2010

The harmonised standards have been compared to the applicable standards used for certification purposes and no changes in the state of the art technical knowledge apply to the listed equipment.

AODD Pumps and Surge Suppressors

Technical File No.: 203104000-1410/MER

AODD (Air-Operated Double Diaphragm) Pumps

EC Type Examination Certificate No. Pumps: KEMA 09ATEX0071 X

DEKRA Certification B.V. (0344)

Meander 1051
6825 MJ Arnhem
The Netherlands

Hazardous Locations Applied:

I M1 c	II 1 G c T5
II 2 G Ex ia c IIC T5	II 1 D c T100°C
II 2 D Ex c ia D 20 IP67 T100°C	II 2 G c T5
II 2 G Eex m c II T5	II 2 D c T100°C
II 2 D c IP65 T100°C	II 2 G c IIB T5

SANDPIPER®
A WARREN RUPP, INC. BRAND

Tranquilizer®

DATE/APPROVAL/TITLE:
18 March 2016

David Roseberry
David Roseberry, Director of Engineering

IDEX