

SERVICE & OPERATING MANUAL

Original Instructions

Certified Quality



SAI GLOBAL

ISO 9001 Certified
ISO 14001 Certified

Member of:
Hydraulic
INSTITUTE

EAC



1935/2004/EC



FDA

UK
CA

Warren Rupp, Inc.
A Unit of IDEX Corporation
800 N. Main St.,
Mansfield, Ohio 44902 USA
Telephone 419.524.8388
Fax 419.522.7867
SANDPIPERPUMP.COM

IDEX

© Copyright 2022 Warren Rupp, Inc.
All rights reserved

Model F30

Metallic Food Processing Pump

Constructed with FDA Approved Materials

Design Level 1

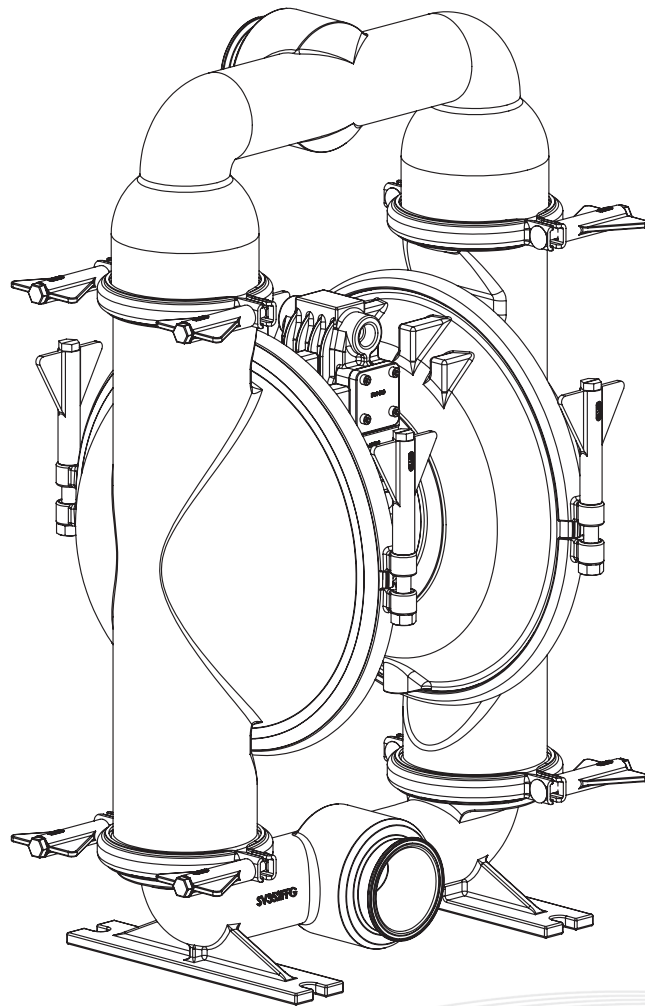

1: PUMP SPECS

2: INSTAL & OP

3: EXP VIEW

4: WARRANTY

SANDPIPER®
A WARREN RUPP, INC. BRAND

SANDPIPERPUMP.COM

Safety Information

IMPORTANT



Read the safety warnings and instructions in this manual before pump installation and start-up. Failure to comply with the recommendations stated in this manual could damage the pump and void factory warranty.



When the pump is used for materials that tend to settle out or solidify, the pump should be flushed after each use to prevent damage. In freezing temperatures the pump should be completely drained between uses.

CAUTION



Before pump operation, inspect all fasteners for loosening caused by gasket creep. Retighten loose fasteners to prevent leakage. Follow recommended torques stated in this manual.



Nonmetallic pumps and plastic components are not UV stabilized. Ultraviolet radiation can damage these parts and negatively affect material properties. Do not expose to UV light for extended periods of time.



WARNING
Pump not designed, tested or certified to be powered by compressed natural gas. Powering the pump with natural gas will void the warranty.



WARNING
The use of non-OEM replacement parts will void (or negate) agency certifications, including CE, ATEX, CSA, 3A and EC1935 compliance (Food Contact Materials). Warren Rupp, Inc. cannot ensure nor warrant non-OEM parts to meet the stringent requirements of the certifying agencies.

WARNING



When used for toxic or aggressive fluids, the pump should always be flushed clean prior to disassembly.



Before maintenance or repair, shut off the compressed air line, bleed the pressure, and disconnect the air line from the pump. Be certain that approved eye protection and protective clothing are worn at all times. Failure to follow these recommendations may result in serious injury or death.



Airborne particles and loud noise hazards. Wear eye and ear protection.



In the event of diaphragm rupture, pumped material may enter the air end of the pump, and be discharged into the atmosphere. If pumping a product that is hazardous or toxic, the air exhaust must be piped to an appropriate area for safe containment.



Take action to prevent static sparking. Fire or explosion can result, especially when handling flammable liquids. The pump, piping, valves, containers and other miscellaneous equipment must be properly grounded.



This pump is pressurized internally with air pressure during operation. Make certain that all fasteners and piping connections are in good condition and are reinstalled properly during reassembly.



Use safe practices when lifting

ATEX Pumps - Conditions For Safe Use

1. Ambient temperature range is as specified in tables 1 & 2 on the next page
2. ATEX compliant pumps are suitable for use in explosive atmospheres when the equipment is properly grounded in accordance with local electrical codes
3. Conductive Polypropylene, conductive Acetal or conductive PVDF pumps are not to be installed in applications where the pumps may be subjected to oil, greases and hydraulic liquids.
4. When operating pumps equipped with non-conductive diaphragms that exceed the maximum permissible projected area, as defined in EN ISO 80079-36 : 2016 section 6.7.5 table 8, the following protection methods must be applied
 - Equipment is always used to transfer electrically conductive fluids or
 - Explosive environment is prevented from entering the internal portions of the pump, i.e. dry running.

Temperature Tables

Table 1. Category 2 ATEX Rated Pumps

Ambient Temperature Range [°C]	Process Temperature Range [°C]	Temperature Class	Maximum Surface Temperature [°C]
-20°C to +60°C	-20°C to +80°C	T5	T100°C
	-20°C to +108°C	T4	T135°C
	-20°C to + 160°C	T3	T200°C
	-20°C to +177°C	(225°C) T2	

Table 2. Category M2 ATEX Rated Pumps for Mining

Ambient Temperature Range [°C]	Process Temperature Range [°C]
-20°C to +60°C	-20°C to +150°C

Note: The ambient temperature range and the process temperature range should not exceed the operating temperature range of the applied plastic parts as listed in the manuals of the pumps.



Table of Contents

1: PUMP SPECS

SECTION 1: PUMP SPECIFICATIONS.....5

- Explanation of Nomenclature
- Performance
- Materials
- Dimensional Drawings

2: INSTAL & OP

SECTION 2: INSTALLATION & OPERATION ...9

- Principle of Pump Operation
- Recommended Installation Guide
- Troubleshooting Guide

3: EXP VIEW

SECTION 3: EXPLODED VIEW.....12

- Composite Repair Parts Drawing
- Service & Repair Kits
- Composite Repair Parts List
- Material Codes

4: WARRANTY

SECTION 7: WARRANTY & CERTIFICATES ..16

- Warranty
- CE Declaration of Conformity - Machinery
-  • CE Declaration of Conformity - EC Regulation 1935/2004/EC



Explanation of Pump Nomenclature

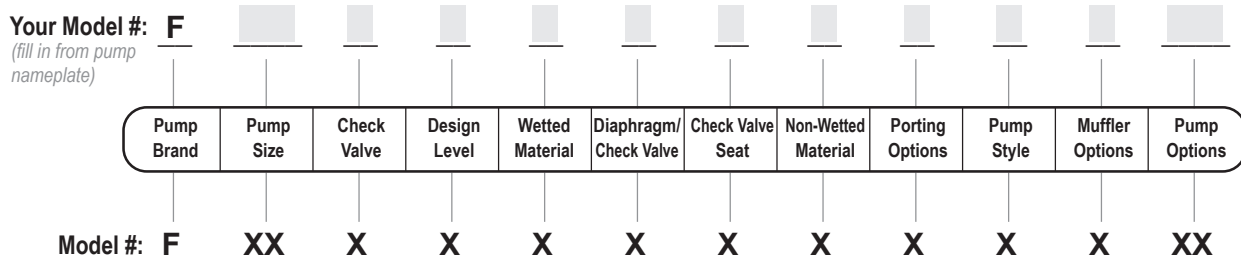

Pump Brand

F Food Processing

Pump Size

30 3"

Check Valve Type

B Ball

Design Level

1 Design Level

Wetted Material

S Stainless Steel

Diaphragm/Check Valve Materials

- D FDA Santoprene / FDA Santoprene
- H FDA Hytrel / FDA Hytrel
- K PTFE with FDA Hytrel Backer / PTFE
- Z PTFE One-Piece Bonded Fusion Diaphragm / PTFE

Check Valve Seat

- D FDA Santoprene
- H FDA Hytrel
- S Stainless Steel
- T PTFE

Non-Wetted Material Options

- A Painted Aluminum
- N Nickel Plated Aluminum
- S Stainless Steel

Porting Options

- T 3" Sanitary Clamp

Pump Style

- F Food

Muffler Options

- 6 Metal Muffler

Pump Options

- 0 None



Your Serial #: *(fill in from pump nameplate)* _____

*Complies with Code of Federal Regulations (CFR) Title 21 Part 177



SANDPIPERPUMP.COM

f30mdl1sm-rev1122

Model F30 Metallic • 5

Tel: 866-777-6060
Fax: 866-777-6383

Springer Pumps, LLC

Website: www.springerpumps.com
Int'l: +001 267 404 2910

Performance

3" Clamped - Food Processing TPE Fitted

1: PUMP SPECS

Flow Rate

Adjustable to 0-234 gpm (886 lpm)

Port Size

Suction 3" SANITARY CLAMP

Discharge 3" SANITARY CLAMP

Air Inlet 1/2" NPT

Air Exhaust 1" NPT

Suction Lift

Dry 20' (6.1 m)

Wet 32' (9.8 m)

Max Solid Size (Diameter)

. 3/8" (9.5 mm)

Max Noise Level 96 dB(A)

Shipping Weights

Stainless 200 lbs (91 kg)

** Stainless Center add 50 lbs. (22.7 kg)

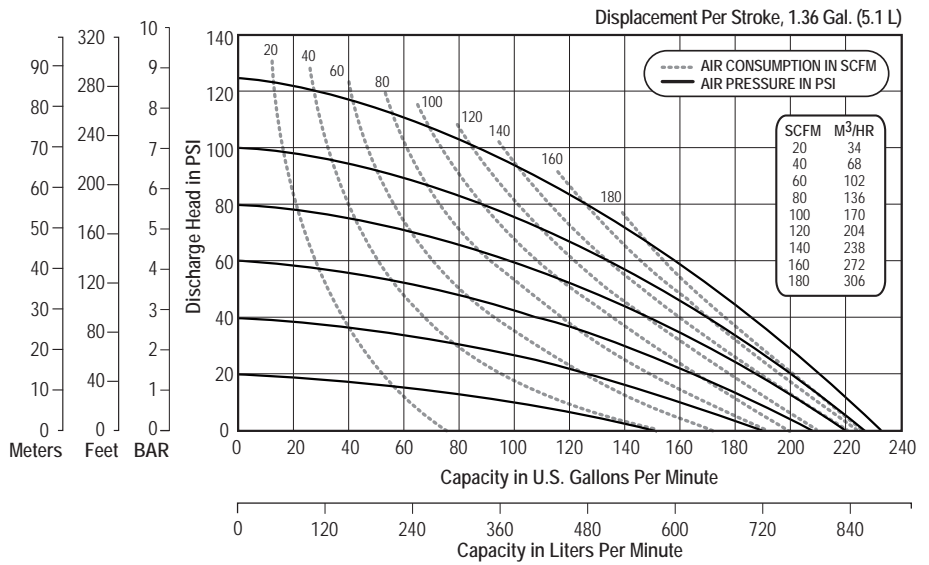

NOTE: Performance based on the following: PTFE fitted pump, flooded suction, water at ambient conditions. The use of other materials and varying hydraulic conditions may result in deviations in excess of 5%.

3" Clamped - Food Processing PTFE Fitted

Flow Rate

Adjustable to 0-180 gpm (681 lpm)

Port Size

Suction 3" SANITARY CLAMP

Discharge 3" SANITARY CLAMP

Air Inlet 1/2" NPT

Air Exhaust 1" NPT

Suction Lift

Dry 12' (3.7 m)

Wet 32' (9.8 m)

Max Solid Size (Diameter)

. 3/8" (9.5 mm)

Max Noise Level 95 dB(A)

Shipping Weights

Stainless 200 lbs (91 kg)

** Stainless Center add 50 lbs. (22.7 kg)

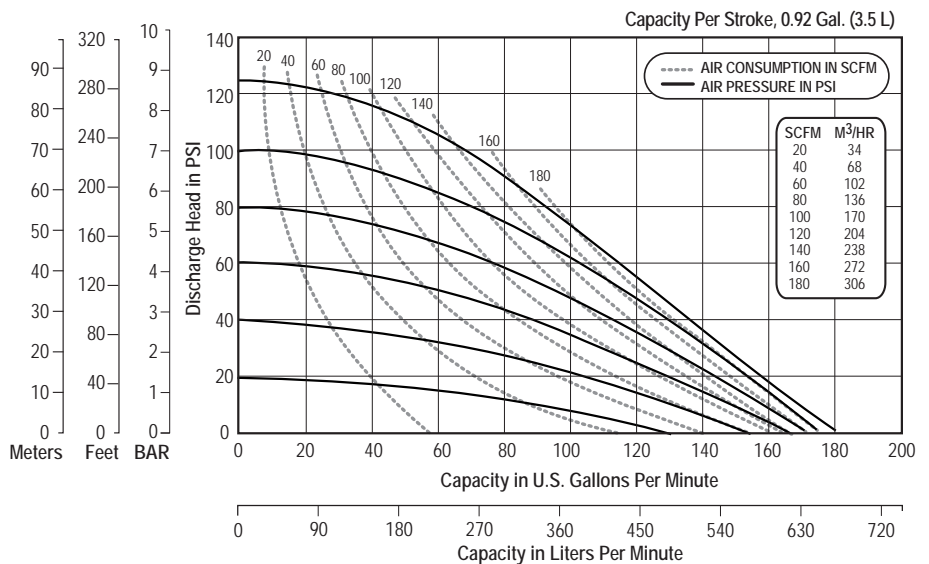

NOTE: Performance based on the following: PTFE fitted pump, flooded suction, water at ambient conditions. The use of other materials and varying hydraulic conditions may result in deviations in excess of 5%.



Materials

Material Profile:	Operating Temperatures:	
	Max.	Min.
EPDM: Shows very good water and chemical resistance. Has poor resistance to oils and solvents, but is fair in ketones and alcohols.	280°F 138°C	-40°F -40°C
Hytrel®: Good on acids, bases, amines and glycols at room temperatures only.	220°F 104°C	-20°F -29°C
Santoprene®: Injection molded thermoplastic elastomer with no fabric layer. Long mechanical flex life. Excellent abrasion resistance.	275°F 135°C	-40°F -40°C
Virgin PTFE: (PFA/TFE) Chemically inert, virtually impervious. Very few chemicals are known to chemically react with PTFE; molten alkali metals, turbulent liquid or gaseous fluorine and a few fluoro-chemicals such as chlorine trifluoride or oxygen difluoride which readily liberate free fluorine at elevated temperatures.	220°F 104°C	-35°F -37°C
<i>Maximum and Minimum Temperatures are the limits for which these materials can be operated. Temperatures coupled with pressure affect the longevity of diaphragm pump components. Maximum life should not be expected at the extreme limits of the temperature ranges.</i>		

Ambient temperature range -20 C to +40 C

Process temperature range -20 C to +80 C for models rated as category 1 equipment
-20 c to +100 C for model rated as category 2 equipment

In addition, the ambient temperature range and the process temperature range do not exceed the operating temperature range of the applied non-metallic parts as listed in the manuals of the pumps.

For specific applications, always consult the Chemical Resistance Chart.

Note: This document is a high level guide. Please be aware that not all model and or material combinations are possible for all sizes. Please consult factory or your distributor for specific details.



SANDPIPER®
A WARREN RUPP, INC. BRAND

SANDPIPERPUMP.COM

f30mdl1sm-rev1122

Model F30 Metallic • 7

Tel: 866-777-6060
Fax: 866-777-6383

Springer Pumps, LLC

Website: www.springerpumps.com
Int'l: +001 267 404 2910

Dimensional Drawings

Food Processing Metallic

Dimensions in inches (mm dimensions in brackets).

The dimensions on this drawing are for reference only. A certified drawing can be requested if physical dimensions are needed.

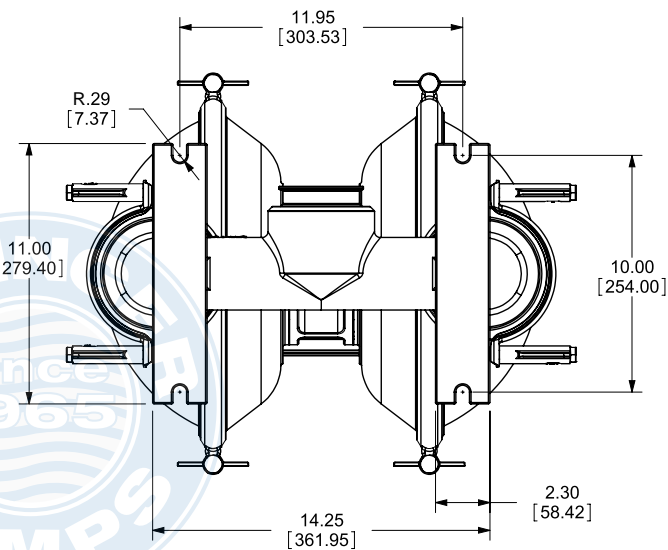
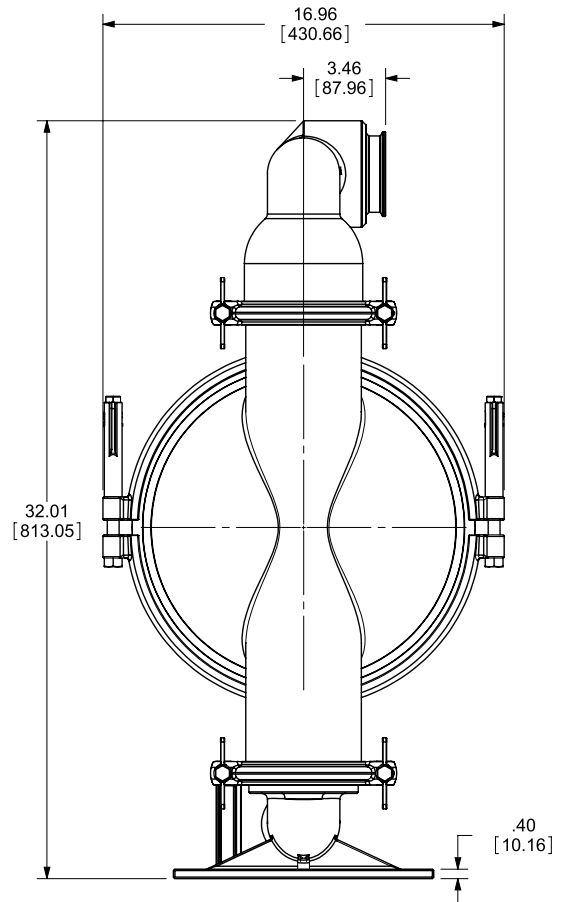
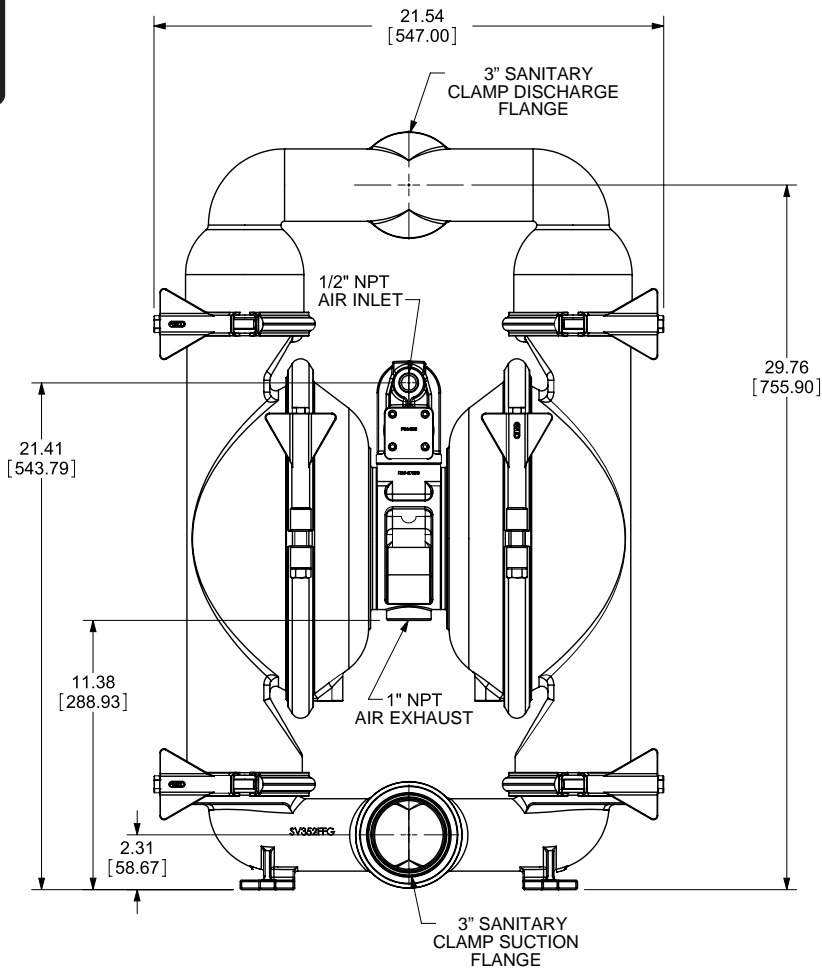

BOTTOM VIEW

Principle of Pump Operation

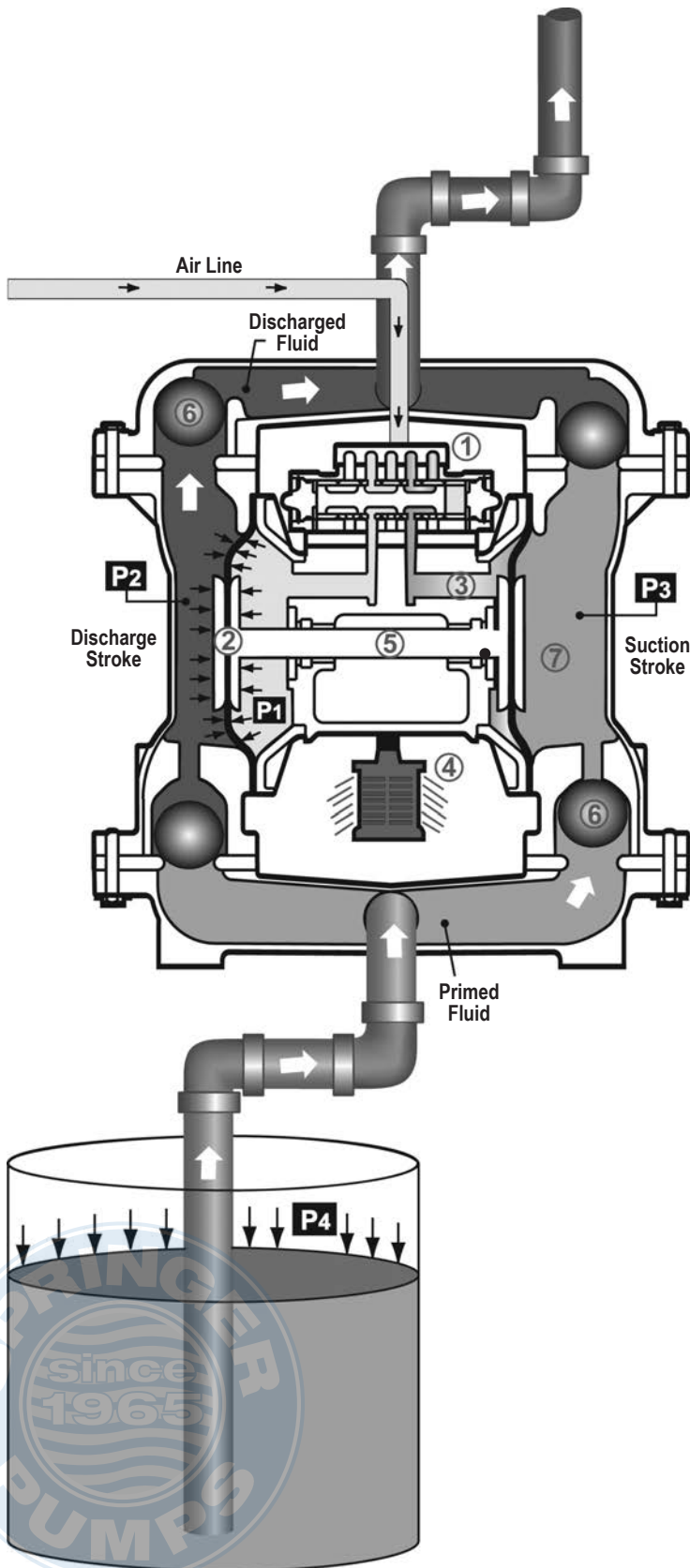

Air-Operated Double Diaphragm (AODD) pumps are powered by compressed air or nitrogen.

The main directional (air) control valve ① distributes compressed air to an air chamber, exerting uniform pressure over the inner surface of the diaphragm ②. At the same time, the exhausting air ③ from behind the opposite diaphragm is directed through the air valve assembly(s) to an exhaust port ④.

As inner chamber pressure (P1) exceeds liquid chamber pressure (P2), the rod ⑤ connected diaphragms shift together creating discharge on one side and suction on the opposite side. The discharged and primed liquid's directions are controlled by the check valves (ball or flap)⑥ orientation.

The pump primes as a result of the suction stroke. The suction stroke lowers the chamber pressure (P3) increasing the chamber volume. This results in a pressure differential necessary for atmospheric pressure (P4) to push the fluid through the suction piping and across the suction side check valve and into the outer fluid chamber ⑦.

Suction (side) stroking also initiates the reciprocating (shifting, stroking or cycling) action of the pump. The suction diaphragm's movement is mechanically pulled through its stroke. The diaphragm's inner plate makes contact with an actuator plunger aligned to shift the pilot signaling valve. Once actuated, the pilot valve sends a pressure signal to the opposite end of the main directional air valve, redirecting the compressed air to the opposite inner chamber.

SUBMERGED ILLUSTRATION

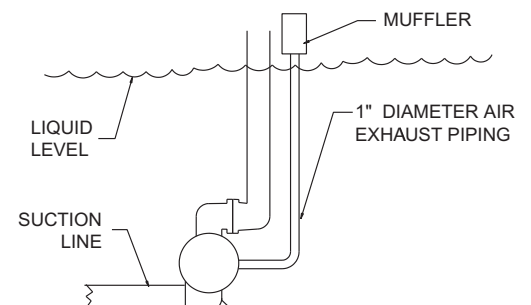

Pump can be submerged if the pump materials of construction are compatible with the liquid being pumped. The air exhaust must be piped above the liquid level. When the pumped product source is at a higher level than the pump (flooded suction condition), pipe the exhaust higher than the product source to prevent siphoning spills.

Recommended Installation Guide

Available Accessories:

1. Surge Suppressor
2. Filter/Regulator
3. Air Dryer
4. Lubricator

Note: Surge Suppressor and Piping, including air line, must be supported after the flexible connections.

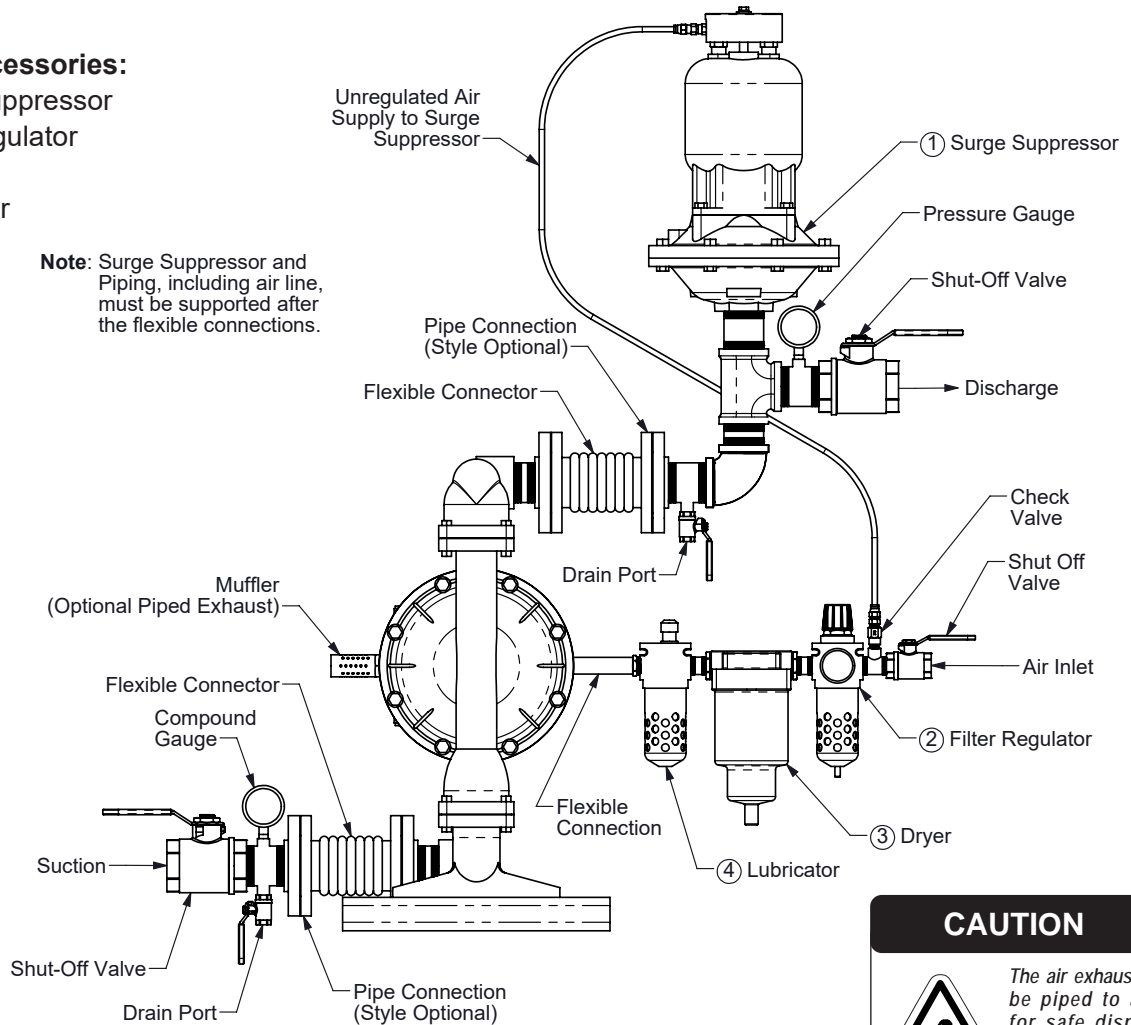

CAUTION



The air exhaust should be piped to an area for safe disposition of the product being pumped, in the event of a diaphragm failure.

Installation And Start-Up

Locate the pump as close to the product being pumped as possible. Keep the suction line length and number of fittings to a minimum. Do not reduce the suction line diameter.

Air Supply

Connect the pump air inlet to an air supply with sufficient capacity and pressure to achieve desired performance. A pressure regulating valve should be installed to insure air supply pressure does not exceed recommended limits.

Air Valve Lubrication

The air distribution system is designed to operate WITHOUT lubrication. This is the standard mode of operation. If lubrication is desired, install an air line lubricator set to deliver one drop of SAE 10 non-detergent oil for every 20 SCFM (9.4 liters/sec.) of air the pump consumes. Consult the Performance Curve to determine air consumption.

Air Line Moisture

Water in the compressed air supply may cause icing or freezing of the exhaust air, causing the pump to cycle erratically or stop operating. Water in the air supply can be reduced by using a point-of-use air dryer.

Air Inlet And Priming

To start the pump, slightly open the air shut-off valve. After the pump primes, the air valve can be opened to increase air flow as desired. If opening the valve increases cycling rate, but does not increase the rate of flow, cavitation has occurred. The valve should be closed slightly to obtain the most efficient air flow to pump flow ratio.

Troubleshooting Guide

2: INSTAL & OP

Symptom:	Potential Cause(s):	Recommendation(s):
Pump Cycles Once	Deadhead (system pressure meets or exceeds air supply pressure).	Increase the inlet air pressure to the pump. Pump is designed for 1:1 pressure ratio at zero flow. (Does not apply to high pressure 2:1 units).
	Air valve or intermediate gaskets installed incorrectly.	Install gaskets with holes properly aligned.
	Bent or missing actuator plunger.	Remove pilot valve and inspect actuator plungers.
Pump Will Not Operate / Cycle	Pump is over lubricated.	Set lubricator on lowest possible setting or remove. Units are designed for lube free operation.
	Lack of air (line size, PSI, CFM).	Check the air line size and length, compressor capacity (HP vs. CFM required).
	Check air distribution system.	Disassemble and inspect main air distribution valve, pilot valve and pilot valve actuators.
	Discharge line is blocked or clogged manifolds.	Check for inadvertently closed discharge line valves. Clean discharge manifolds/piping.
	Deadhead (system pressure meets or exceeds air supply pressure).	Increase the inlet air pressure to the pump. Pump is designed for 1:1 pressure ratio at zero flow. (Does not apply to high pressure 2:1 units).
	Blocked air exhaust muffler.	Remove muffler screen, clean or de-ice, and re-install.
	Pumped fluid in air exhaust muffler.	Disassemble pump chambers. Inspect for diaphragm rupture or loose diaphragm plate assembly.
Pump Cycles and Will Not Prime or No Flow	Pump chamber is blocked.	Disassemble and inspect wetted chambers. Remove or flush any obstructions.
	Cavitation on suction side.	Check suction condition (move pump closer to product).
	Check valve obstructed. Valve ball(s) not seating properly or sticking.	Disassemble the wet end of the pump and manually dislodge obstruction in the check valve pocket. Clean out around valve ball cage and valve seat area. Replace valve ball or valve seat if damaged. Use heavier valve ball material.
	Valve ball(s) missing (pushed into chamber or manifold).	Worn valve ball or valve seat. Worn fingers in valve ball cage (replace part). Check Chemical Resistance Guide for compatibility.
	Valve ball(s) / seat(s) damaged or attacked by product.	Check Chemical Resistance Guide for compatibility.
	Check valve and/or seat is worn or needs adjusting.	Inspect check valves and seats for wear and proper setting. Replace if necessary.
	Suction line is blocked.	Remove or flush obstruction. Check and clear all suction screens or strainers.
	Excessive suction lift.	For lifts exceeding 20' of liquid, filling the chambers with liquid will prime the pump in most cases.
	Suction side air leakage or air in product.	Visually inspect all suction-side gaskets and pipe connections.
	Pumped fluid in air exhaust muffler.	Disassemble pump chambers. Inspect for diaphragm rupture or loose diaphragm plate assembly.
Pump Cycles Running Sluggish / Stalling, Flow Unsatisfactory	Over lubrication.	Set lubricator on lowest possible setting or remove. Units are designed for lube free operation.
	Icing.	Remove muffler screen, de-ice, and re-install. Install a point of use air drier.
	Clogged manifolds.	Clean manifolds to allow proper air flow.
	Deadhead (system pressure meets or exceeds air supply pressure).	Increase the inlet air pressure to the pump. Pump is designed for 1:1 pressure ratio at zero flow. (Does not apply to high pressure 2:1 units).
	Cavitation on suction side.	Check suction (move pump closer to product).
	Lack of air (line size, PSI, CFM).	Check the air line size, length, compressor capacity.
	Excessive suction lift.	For lifts exceeding 20' of liquid, filling the chambers with liquid will prime the pump in most cases.
	Air supply pressure or volume exceeds system hd.	Decrease inlet air (press. and vol.) to the pump. Pump is cavitating the fluid by fast cycling.
	Undersized suction line.	Meet or exceed pump connections.
	Restrictive or undersized air line.	Install a larger air line and connection.
	Suction side air leakage or air in product.	Visually inspect all suction-side gaskets and pipe connections.
	Suction line is blocked.	Remove or flush obstruction. Check and clear all suction screens or strainers.
	Pumped fluid in air exhaust muffler.	Disassemble pump chambers. Inspect for diaphragm rupture or loose diaphragm plate assembly.
	Check valve obstructed.	Disassemble the wet end of the pump and manually dislodge obstruction in the check valve pocket.
	Check valve and/or seat is worn or needs adjusting.	Inspect check valves and seats for wear and proper setting. Replace if necessary.
Product Leaking Through Exhaust	Entrained air or vapor lock in chamber(s).	Purge chambers through tapped chamber vent plugs. Purging the chambers of air can be dangerous.
	Diaphragm failure, or diaphragm plates loose.	Replace diaphragms, check for damage and ensure diaphragm plates are tight.
Premature Diaphragm Failure	Diaphragm stretched around center hole or bolt holes.	Check for excessive inlet pressure or air pressure. Consult Chemical Resistance Chart for compatibility with products, cleaners, temperature limitations and lubrication.
	Cavitation.	Enlarge pipe diameter on suction side of pump.
	Excessive flooded suction pressure.	Move pump closer to product. Raise pump/place pump on top of tank to reduce inlet pressure. Install Back pressure device (Tech bulletin 41r). Add accumulation tank or pulsation dampener.
	Misapplication (chemical/physical incompatibility).	Consult Chemical Resistance Chart for compatibility with products, cleaners, temperature limitations and lubrication.
Unbalanced Cycling	Incorrect diaphragm plates or plates on backwards, installed incorrectly or worn.	Check Operating Manual to check for correct part and installation. Ensure outer plates have not been worn to a sharp edge.
	Excessive suction lift.	For lifts exceeding 20' of liquid, filling the chambers with liquid will prime the pump in most cases.
	Undersized suction line.	Meet or exceed pump connections.
	Pumped fluid in air exhaust muffler.	Disassemble pump chambers. Inspect for diaphragm rupture or loose diaphragm plate assembly.
	Suction side air leakage or air in product.	Visually inspect all suction-side gaskets and pipe connections.
	Check valve obstructed.	Disassemble the wet end of the pump and manually dislodge obstruction in the check valve pocket.
	Check valve and/or seat is worn or needs adjusting.	Inspect check valves and seats for wear and proper setting. Replace if necessary.
Entrained air or vapor lock in chamber(s).	Purge chambers through tapped chamber vent plugs.	

For additional troubleshooting tips contact After Sales Support at service.warrenrupp@idexcorp.com or 419-524-8388



SANDPIPERPUMP.COM

Model F30 Metallic • 11

f30mdl1sm-rev1122

Tel: 866-777-6060
Fax: 866-777-6383

Springer Pumps, LLC

Website: www.springerpumps.com
Int'l: +001 267 404 2910

Composite Repair Parts Drawing - TPE Fitted

3: EXP VIEW

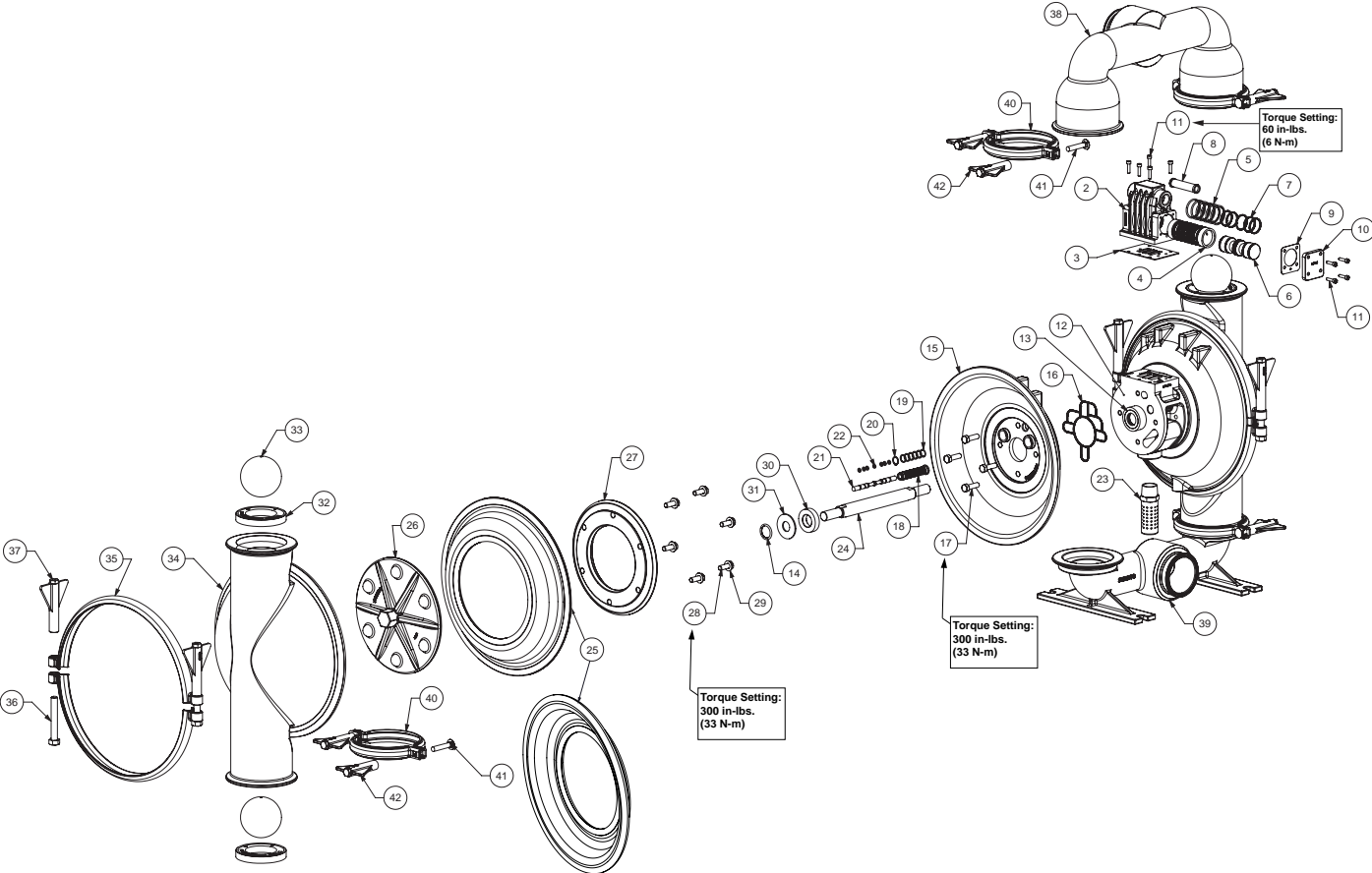

Optional orientation:
To ease assembly of the TPE diaphragms,
one of the diaphragms may be reversed.



Composite Repair Parts List - TPE Fitted

Air Valve Assembly				
Item #	Qty.	Description	Part Number	
			Nickle Plated	Stainless Steel
		Air Side Repair Kit (Includes Items 3,5,7,9,14,16,18-22)	476.V029.000	476.V030.000
1	1	Valve Body (includes items 2-11)	031.V003.332	031.V003.114
2	1	Valve Body	095.V001.332	095.V001.114
3	1	Valve Body Gasket	P24-202	
4	1	Valve Sleeve	755.V005.148	
5	6	O-ring	560.206.360	
6	1	Valve Spool Assembly (Includes items 7)	775.V001.000	
7	6	Glyde Ring Assembly	P34-204F	
8	1	Air Valve Screen	P24-210	P34-210
9	2	End Cap Gasket	P24-205	
10	2	End Cap	SP34-300	
11	13	Mounting Screws (8 included on item 1)	S1001	
Center Section Assembly				
Item #	Qty.	Description	Part Number	
			Nickle Plated	Stainless Steel
12	1	Center Block Assembly (Includes item 13 & 14)	P34-401NP	SP34-400
13	2	Bearing Sleeve	P34-404	
14	2	Main Shaft O-Ring	P34-403	
15	2	Air Chamber	196.V006.110	
16	2	Air Chamber Gasket	360.V001.360	
17	8	Bolt	SP34-110	
		Pilot Repair Kit (Includes Items 18-22)	476.V028.000	
18	1	Pilot Sleeve Assembly (include item 19)	755.V002.000	
19	6	O-ring	560.101.358	
20	1	Retaining Ring	675.037.080	
21	1	Pilot Spool Assembly (Includes item 22)	775.V006.000	
22	8	O-ring	560.023.358	
23	1	Muffler	530.033.000	
Diaphragm Assembly / Elastomers				
Item #	Qty.	Description	Part Number	
			FDA Hytrel	FDA Santoprene
24	1	Main Shaft	P34-103	
25	2	Diaphragm	V305TPEFG	V305TPEXLFG
26	2	Outer Diaphragm Plate	SV302BFG	
27	2	Inner Diaphragm Plate	V302CDCNP	SV302C
28	12	Bolt	SV302G	
29	12	Washer	SV302GA	
30	2	Bumper Washer	P34-501	
31	2	Back-Up Washer	V302E	
32	4	Valve Seat	V356TPEFG	V240TPEXLFG
33	4	Valve Ball	V355TPEFG	V241TPEXLFG
Wet End Assembly				
Item #	Qty.	Description	Part Number	
34	2	Water Chamber	SV350FG	
35	4	Large Clamp Half	SV311A	
36	4	Bolt	SV311C	
37	4	Large Wing Nut	FG11D	
38	1	Discharge Manifold	SV351FG	
39	1	Suction Manifold	SV352FFG	
40	8	Small Clamp Half	SV354A	
41	8	Bolt	SV354B	
42	8	Small Wing Nut	FG30D	

3: EXP VIEW

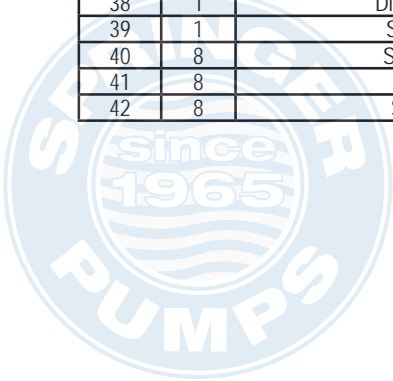

Composite Repair Parts Drawing - PTFE Fitted

3: EXP VIEW

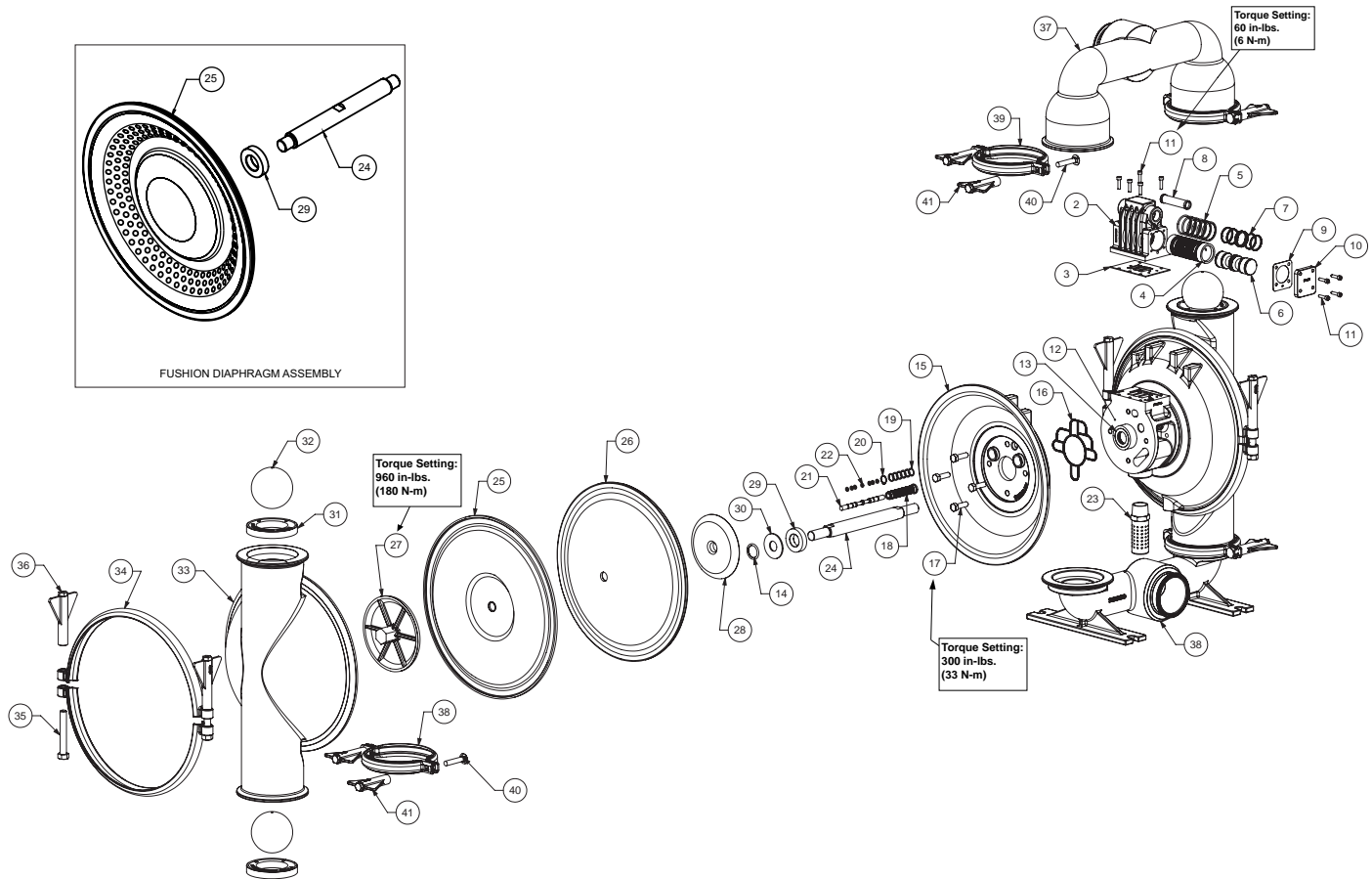
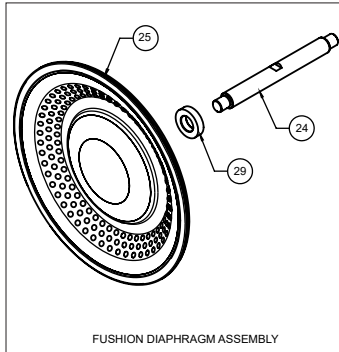

Service & Repair Kits

- 476.381.351 Wet End Kit**
FDA Santoprene Diaphragms, FDA Santoprene Check Balls,
FDA Santoprene Seats
- 476.381.350 Wet End Kit**
FDA Hytrel Diaphragms, FDA Hytrel Check Balls,
FDA Hytrel Seats
- 476.385.663 Wet End Kit**
Hytrel Diaphragms, PTFE Diaphragms, PTFE Check Balls,
PTFE Seat O-Rings

- 476.385.659 Wet End Kit**
1-Piece PTFE Diaphragms, PTFE Check Balls,
PTFE Seat O-Rings
- 476.376.000 Air End Kit**
Sleeve and Spool Set, Buna O-Rings, Buna Gaskets,
Glyd-Ring Set, Buna Bushings

Composite Repair Parts List - PTFE Fitted

Air Valve Assembly						
Item #	Qty.	Description	Part Number			
			Nickle Plated		Stainless Steel	
		Air Side Repair Kit (Includes Items 3,5,7,9,14,16,18-22)	476.V029.000		476.V030.000	
1	1	Valve Body (includes items 2-11)	031.V003.332		031.V003.114	
2	1	Valve Body	095.V001.332		095.V001.114	
3	1	Valve Body Gasket	P24-202			
4	1	Valve Sleeve	755.V005.148			
5	6	O-ring	560.206.360			
6	1	Valve Spool Assembly (Includes items 7)	775.V001.000			
7	6	Glyde Ring Assembly	P34-204F			
8	1	Air Valve Screen	P24-210		P34-210	
9	2	End Cap Gasket	P24-205			
10	2	End Cap	SP34-300			
11	13	Mounting Screws (8 included on item 1)	S1001			
Center Section Assembly						
Item #	Qty.	Description	Part Number			
			Nickle Plated		Stainless Steel	
12	1	Center Block Assembly (Includes item 13 & 14)	P34-400NP ASY		SP34-400	
13	2	Bearing Sleeve	P34-404			
14	2	Main Shaft O-Ring	P34-403			
15	2	Air Chamber	196.V006.110			
16	2	Air Chamber Gasket	P24-109A			
17	8	Bolt	SP34-110			
		Pilot Repair Kit (Includes Items 18-22)	476.V028.000			
18	1	Pilot Sleeve Assembly (include item 19)	755.V002.000			
19	6	O-ring	560.101.358			
20	1	Retaining Ring	675.037.080			
21	1	Pilot Spool Assembly (Includes item 22)	775.V006.000			
22	8	O-ring	560.023.358			
23	1	Muffler	530.033.000			
Diaphragm Assembly / Elastomers						
Item #	Qty.	Description	Part Number			
			Nickle Plated Air End		Stainless Steel Air End	
			PTFE Two Piece	FUSION	PTFE Two Piece	FUSION
24	1	Main Shaft	P34-103	P34-103F	P34-103	P34-103F
25	2	Diaphragm	V305TF	V305F	V305TF	V305F
26	1	Back Up Diaphragm	V305TFB	N/A	V305TFB	N/A
27	2	Outer Diaphragm Plate	SV302TOFG	N/A	SV302TOFG	N/A
28	2	Inner Diaphragm Plate	V302TINP	N/A	SV302TI	N/A
29	2	Bumper Washer	P34-501		P34-501	
30	2	Back-Up Washer	V302E	N/A	V302E	N/A
31	4	Valve Seat (See Material Chart Below)	xV356xx		XV356XX	
32	4	Valve Ball	V355TF		V355TF	
Wet End Assembly						
Item #	Qty.	Description	Part Number			
33	2	Water Chamber	SV350FG			
34	4	Large Clamp Half	SV311A			
35	4	Bolt	SV311C			
36	4	Large Wing Nut	FG11D			
37	1	Discharge Manifold	SV351FG			
38	1	Suction Manifold	SV352FFG			
39	8	Small Clamp Half	SV354A			
40	8	Bolt	SV354B			
41	8	Small Wing Nut	FG30D			
42	2	Diaphragm Seal Tape Kit (Not Pictured)	720.V006.000			
Material Specifications						
Material	"Ball P/N"		Seat P/N			
PTFE	V355TF		V356TF			
Stainless Steel	N/A		SV356 (See Note 1 Below)			

Notes:

In addition to this seat, (4) V356T O-Rings are needed.

3: EXP VIEW



5 - YEAR Limited Product Warranty

Warren Rupp, Inc. ("Warren Rupp") warrants to the original end-use purchaser that no product sold by Warren Rupp that bears a Warren Rupp brand shall fail under normal use and service due to a defect in material or workmanship within five years from the date of shipment from Warren Rupp's factory. Warren Rupp brands include Warren Rupp®, SANDPIPER®, SANDPIPER Signature Series™, MARATHON®, Porta-Pump®, SludgeMaster™ and Tranquilizer®.

The use of non-OEM replacement parts will void (or negate) agency certifications, including CE, ATEX, CSA, 3A and EC1935 compliance (Food Contact Materials). Warren Rupp, Inc. cannot ensure nor warrant non-OEM parts to meet the stringent requirements of the certifying agencies.

- See complete warranty at <https://www.sandpiperpump.com/>



EC Declaration of Conformity

Manufacturer:
Warren Rupp, Inc.
800 N. Main Street
Mansfield, Ohio, 44902 USA

Certifies that Air-Operated Double Diaphragm Pump Models: DSB Series, DMF Series, G Series, HDB Series, HDF Series, HP Series, F Series, MS Series, S Series, SL Series, SP Series, SSB Series, T Series, U1F Series, WR Series; High Pressure Pump Models: EH Series, GH Series, SH Series; Submersible Pump Models: SMA3 Series, SPA Series; and Surge Dampener/Suppressor Models: DA Series, TA Series comply with the European Community Directive 2006/42/EC on Machinery, according to Annex VIII. This product has used Harmonized Standard EN809:2012, Pumps and Pump Units for Liquids - Common Safety Requirements, to verify conformance.

October 3, 2022

DATE/APPROVAL/TITLE:

Technical File on record with:
DEKRA Certification B.V.
Meander 1051
6825 MJ Arnhem
The Netherlands

Signature of authorized person

Dennis Hall

Printed name of authorized person

Engineering Manager

Title

4: WARRANTY





EC Declaration of Conformity

Manufacturer:
Warren Rupp, Inc.
800 N. Main Street
Mansfield, Ohio, 44902 USA

Certifies that Air-Operated Double Diaphragm Pump Models: DSB Series, DMF Series, G Series, HDB Series, HDF Series, HP Series, F Series, MS Series, S Series, SL Series, SP Series, SSB Series, T Series, U1F Series, WR Series; High Pressure Pump Models: EH Series, GH Series, SH Series; Submersible Pump Models: SMA3 Series, SPA Series; and Surge Dampener/Suppressor Models: DA Series, TA Series comply with the United Kingdom Statutory Instruments 2008 No. 1597, The Supply of Machinery (Safety) Regulations 2008, according to Annex VIII. This product has used Designated Standard EN809:2012, Pumps and Pump Units for Liquids - Common Safety Requirements, to verify conformance.

October 17, 2022

DATE/APPROVAL/TITLE:

Technical File on record with:
DEKRA Certification UK Limited
Stokenchurch House
Oxford Road
Stokenchurch
HP14 3SX



Signature of authorized person

Dennis Hall

Printed name of authorized person

Engineering Manager

Title





Declaration of Compliance

Manufacturer: Warren Rupp, Inc., 800 N. Main Street, Mansfield, Ohio, 44902 USA

certifies that the below Air-Operated Double Diaphragm Food Processing Pump Models and Tranquilizer® Surge Suppressor Models comply with the European Community Regulations:

(EC) No 1935/2004 for Food Contact Materials

(EC) No 2023/2006 Good Manufacturing Practice

(EU) No 10/2011 on plastic materials and articles intended to come in contact with food

Food Processing Pump Models:

F##B1SDD#TF600	F##B1SHD#TF600	F##B1SKD#TF600	F##B1SZD#TF600
F##B1SDH#TF600	F##B1SHH#TF600	F##B1SKH#TF600	F##B1SZH#TF600
F##B1SDS#TF600	F##B1SHS#TF600	F##B1SKS#TF600	F##B1SZS#TF600
F15B1SDS#TC600	F15B1SHS#TC600	F15B1SKS#TC600	F15B1SZS#TC600
F20B1SDS#TC600	F20B1SHS#TC600	F20B1SKS#TC600	F20B1SZS#TC600
SSB2,TD3SS			
T##B1S9S#TS600	T##B1SAS#TS600	T##B1SDS#TS600	T##B1SLS#TS600
T##B1S9T#TS600	T##B1SAT#TS600	T##B1SDT#TS600	T##B1SLT#TS600

Tranquilizer® Surge Suppressors:

TA1,NG1SS.	TA2,NG2SS.	TA25,NG1SS.	TA50,NG2SS.
TA1-1/2,NG1SS.	TA3,NG2SS.	TA40,NG1SS.	TA80,NG2SS.

- Materials used in equipment intended for food contact (Annex I (EC) No 1935/2004) :
 - Rubber
 - Metals & Alloys
 - Plastics

Plastic Materials: PTFE and FKM/ PTFE coated

The plastic components are suitable to come in contact with multiple food types, provided that storage contact time does not exceed 1/2 hour, contact temperature does not exceed 40°C and maximum operating temperatures within the instructions manual are not exceeded. Diaphragm failure may allow process fluids to come in contact with nonconforming materials. Regular inspections are recommended.

- This Declaration is based on :
 - Declaration of Conformities from raw material suppliers
 - Total Migration Analysis per (EU) No 10/2011
- Supporting document will be made available to competent authorities to demonstrate compliance

Signature of authorized person

Dennis Hall

Printed name of authorized person

February 8, 2013

Date of issue

Engineering Manager

Title

October 3, 2022

Date of revision





ATEX



EU Declaration of Conformity

Manufacturer:
Warren Rupp, Inc.
A Unit of IDEX Corporation
800 North Main Street
Mansfield, OH 44902 USA

This declaration of conformity is issued under the sole responsibility of the manufacturer. Warren Rupp, Inc. declares that Air Operated Double Diaphragm Pumps (AODD) and Surge Suppressors listed below comply with the requirements of Directive **2014/34/EU** and applicable harmonized standards.

Harmonized Standards:

- EN ISO 80079-36: 2016
- EN ISO 80079-37: 2016
- EN 60079-25: 2010

1. AODD Pumps and Surge Suppressors - Technical File on record with DEKRA Certification B.V.
Meander 1051
6825 MJ Arnhem
The Netherlands

Hazardous Location Applied:



II 2 G Ex h IIC T5...225°C (T2) Gb
II 2 D Ex h IIIC T100°C...T200°C Db

- Metallic pump models with external aluminum components (DMF Series, EH Series, F Series, G & GH Series, HDB Series, HDF Series, MS Series, S Series, SH Series, SL Series, SP Series, ST Series, T Series, and U1F Series)
- Conductive plastic pump models with integral muffler (PB Series, S Series, SL Series, SP Series)
- Tranquilizer® surge suppressors (TA Series)



II 2 G Ex h IIB T5...225°C (T2) Gb
II 2 D Ex h IIIB T100°C...T200°C Db

- ST Series with sight tubes (VL) and HP Series because of the projected area of non-conductive external components

2. AODD Pumps - EU Type Examination Certificate No.: DEKRA 18ATEX0094X - DEKRA Certification B.V. (0344)
Meander 1051
6825 MJ Arnhem
The Netherlands

Hazardous Location Applied:



I M1 Ex h I Ma
II 1 G Ex h IIC T5...225°C (T2) Ga
II 1 D Ex h IIIC T100°C...T200°C Da

- Metallic pump models with no external aluminum (S series, HDB Series, HDF Series, G Series)
- Conductive plastic pumps equipped with metal muffler (S series, PB Series)



II 2 G Ex h ia IIC T5 Gb
II 2 D Ex h ia IIIC T100°C Db

- All pump model series excluding G15, G20, G30 equipped with ATEX rated pulse output option



II 2 G Ex h mb IIC T5 Gb
II 2 D Ex h mb tb IIIC T100° Db

- Pump model series S05, S1F, S15, S20, S30 equipped with ATEX rated integral solenoid option

- See "ATEX Details" page in user's manual for more information
- See "Safety Information" page for conditions of safe use

DATE/APPROVAL/TITLE:
03 OCT 2022

Dennis Hall
Engineering Manager



UKEx



EU Declaration of Conformity

Manufacturer:
Warren Rupp, Inc.
A Unit of IDEX Corporation
800 North Main Street
Mansfield, OH 44902 USA

This declaration of conformity is issued under the sole responsibility of the manufacturer.
Warren Rupp, Inc declares that Air Operated Double Diaphragm Pumps (AODD) and Surge Suppressors listed below comply with the requirements of United Kingdom Statutory Instruments **2016 No. 1107** and all the applicable standards.

Designated Standards:

- EN ISO 80079-36: 2016
- EN ISO 80079-37: 2016
- EN 60079-25: 2010

1. AODD Pumps and Surge Suppressors - Technical File on record with: DEKRA Certification UK Limited
 Stokenchurch House
 Oxford Road
 Stokenchurch
 HP14 3SX

Hazardous Location Applied:



II 2 G Ex h IIC T5...225°C (T2) Gb
II 2 D Ex h IIIC T100°C...T200°C Db

- Metallic pump models with external aluminum components (DMF Series, EH Series, F Series, G & GH Series, HDB Series, HDF Series, MS Series, S Series, SH Series, SL Series, SP Series, ST Series, T Series, and U1F Series)
- Conductive plastic pump models with integral muffler (PB Series, S Series, SL Series, SP Series)
- Tranquilizer® surge suppressors (TA Series)



II 2 G Ex h IIB T5...225°C (T2) Gb
II 2 D Ex h IIIB T100°C...T200°C Db

- ST Series with sight tubes (VL) and HP Series because of the projected area of non-conductive external components



- See "ATEX Details" page in user's manual for more information
- See "Safety Information" page for conditions of safe use

DATE/APPROVAL/TITLE:
17 OCT 2022

Dennis Hall
Engineering Manager