

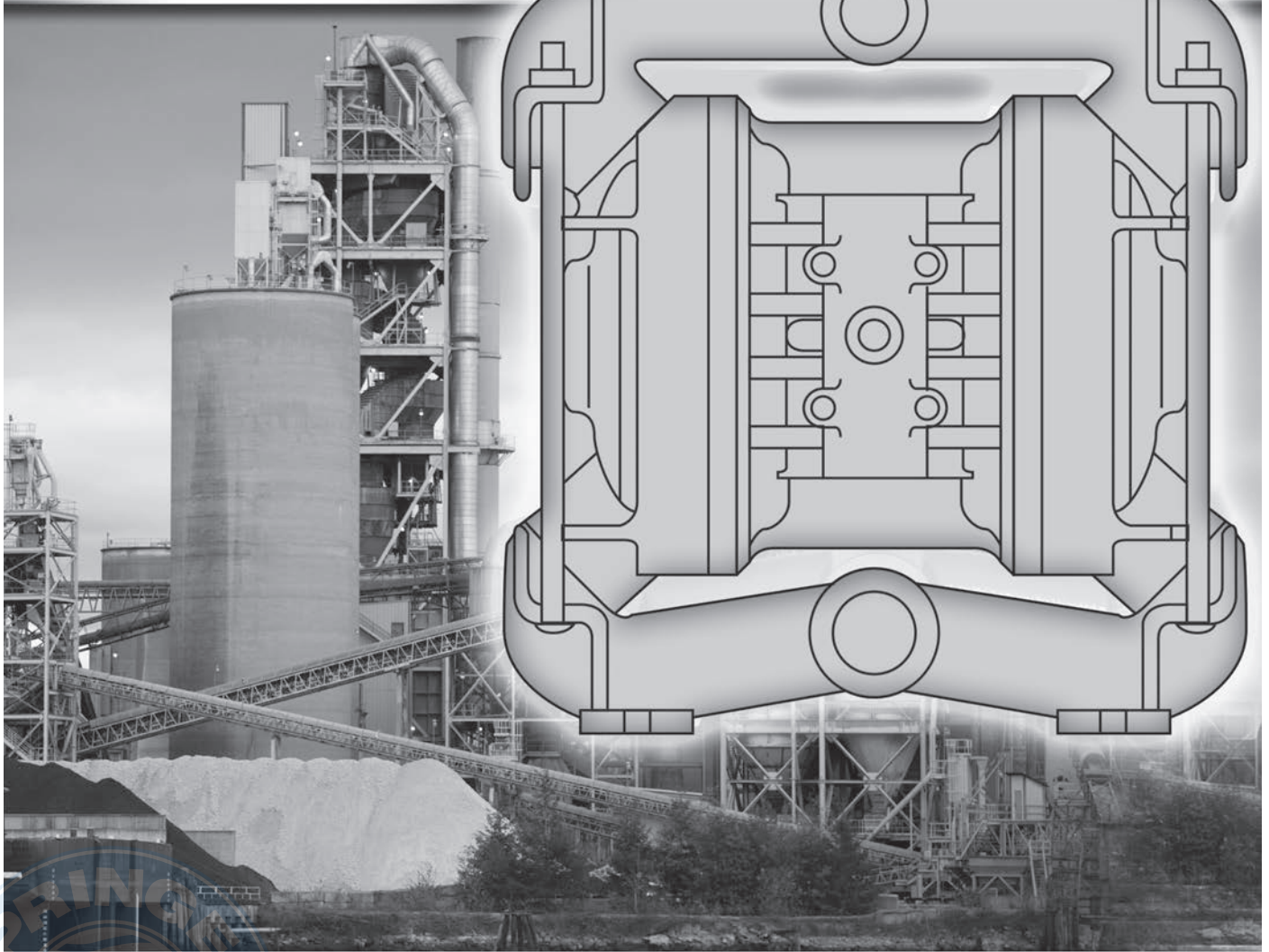
NOMAD



# NOMAD™

## OPERATION MANUAL

### NTG25 NOMAD TRANS-FLO™



AIR-OPERATED



DOUBLE DIAPHRAGM



PUMPS

ALUMINUM Models

316 S.S. Models



A JDA Global Company

1/14 rev. 3

Tel: 866-777-6060

Fax: 866-777-6383

Springer Pumps, LLC

Website: [www.springerpumps.com](http://www.springerpumps.com)

Int'l: +001 267 404 2910

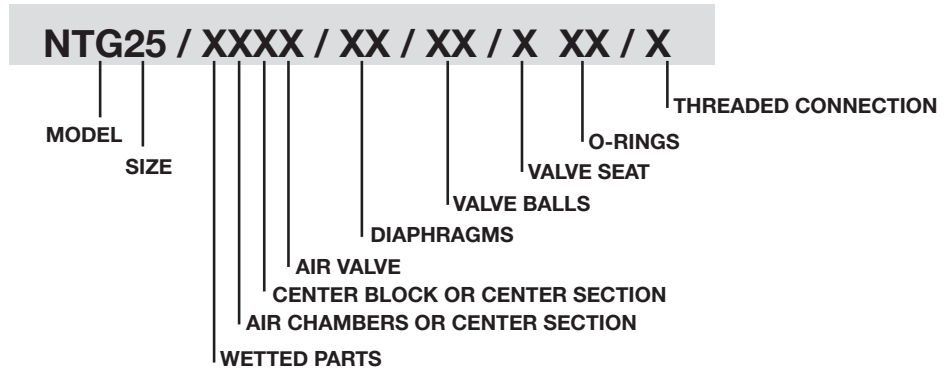
**CAUTION – SAFETY POINTS**

<b>TEMPERATURE LIMITS:</b>		
Neoprene	-17.8°C to 93.3°C	0°F to 200°F
Buna-N	-12.2°C to 82.2°C	10°F to 180°F
EPDM	-51.1°C to 137.8°C	-60°F to 280°F
Viton®	-40°C to 176.7°C	-40°F to 350°F
Santoprene®	-40°C to 107.2°C	-40°F to 225°F
Polyurethane	12.2°C to 65.6°C	10°F to 150°F
Hytrel®	-28.9°C to 104.4°C	-20°F to 220°F
PTFE	4.4°C to 104.4°C	40°F to 220°F

1. Review the NOMAD Chemical Field Guide for all applications. The information provided is the “best thinking available” regarding chemical compatibility. The guide however, does not provide a recommendation.
2. Always wear safety glasses during pump operation. A diaphragm rupture may force liquid to exit via air exhaust.
3. When handling flammable fluids, prevent static sparking by properly grounding the pump.
4. Do not exceed 125 psig (8.6 bar).
5. Prior to maintenance, compressed air line should be disconnected to allow air pressure to bleed from pump.
6. Tighten all clamp bands and hardware parts prior to installation. Fittings may loosen during transportation.

## PUMP DESIGNATION SYSTEM

**25 mm (1") Pump**  
**Maximum Flow Rate:**  
**133 lpm (35 gpm)**



## MATERIAL CODES

### MODEL

NTG25 = 25MM (1")

### WETTED PARTS & OUTER PISTON

AA = ALUMINUM / ALUMINUM  
 S = 316 S.S.

### AIR CHAMBERS

P = POLYPROPYLENE (CENTER SECTION)  
 A = ALUMINUM

### CENTER BLOCK

P = POLYPROPYLENE  
 A = ALUMINUM

### AIR VALVE

B = BRASS

### DIAPHRAGMS

BN = BUNA-N (Red Dot)  
 FS = HYTREL  
 ND = EPDM (Blue Dot)  
 NE = NEOPRENE (Green Dot)  
 SN = SANTOPRENE  
 TF = PTFE

### VALVE BALL

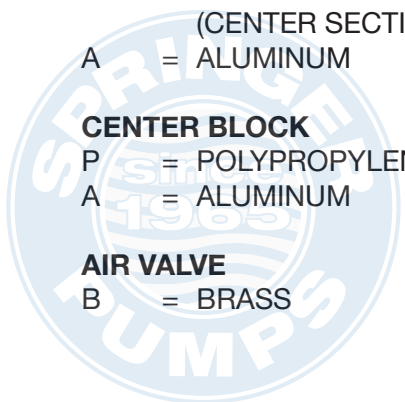
BN = BUNA-N (Red Dot)  
 FS = HYTREL  
 ND = EPDM (Blue Dot)  
 NE = NEOPRENE (Green Dot)  
 TF = PTFE (White)  
 SN = SANTOPRENE

### VALVE SEAT

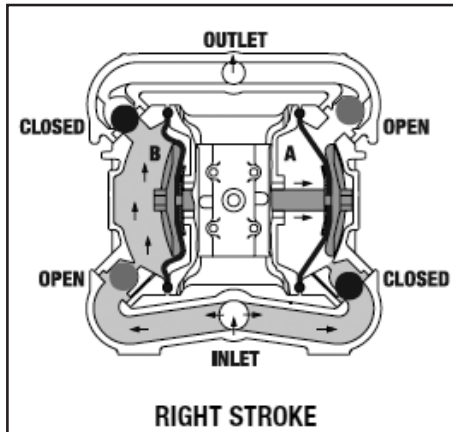
A = ALUMINUM\*  
 S = STAINLESS\*  
 \*Valve seat o-ring required.

### VALVE SEAT O-RING

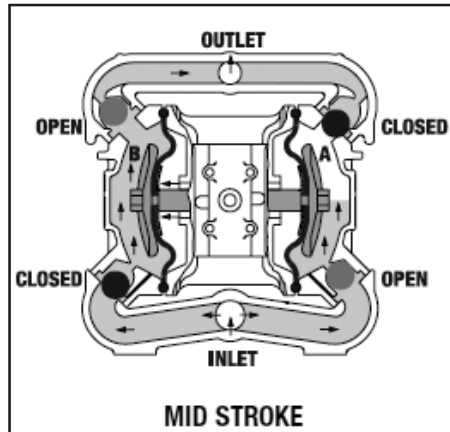
BN = BUNA-N  
 FS = HYTREL  
 ND = EPDM  
 NE = NEOPRENE  
 SN = SANTOPRENE  
 TF = PTFE



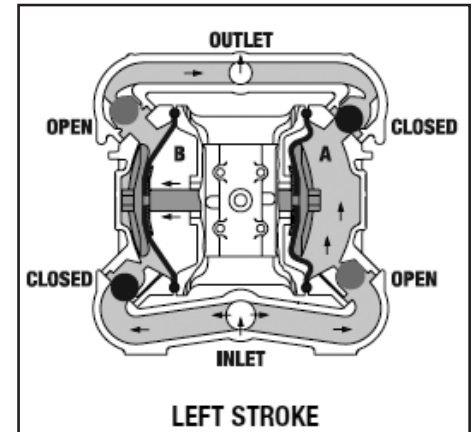
## AIR OPERATED DOUBLE DIAPHRAGM PUMPS FUNCTIONALITY AND FLOW PATTERN



**Figure 1:** Air valve directs pressurized air to the back side of diaphragm A. Compressed air is applied directly to the liquid column separated by elastomeric diaphragms. The diaphragm acts as a separation membrane between the compressed air and liquid, balancing the load and removing mechanical stress from the diaphragm. The opposite diaphragm is pulled in by the shaft connected to the pressurized diaphragm. Diaphragm B is on its suction stroke; air behind the diaphragm has been forced out to the atmosphere through the exhaust port of the pump. Atmospheric pressure forces fluid into the inlet manifold forcing the inlet valve ball off its seat. Liquid is free to move past the inlet valve ball and fill the liquid chamber (see shaded area).

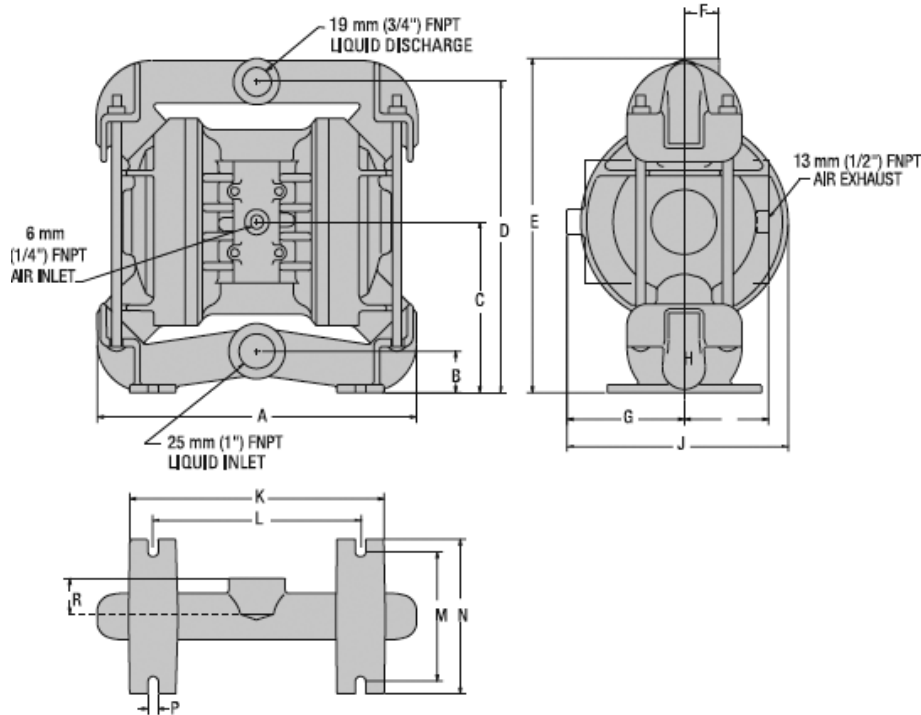


**Figure 2:** When the pressurized diaphragm, diaphragm A, reaches the limit of its discharge stroke, the air valve redirects pressurized air to the back side of the diaphragm B. The pressurized air forces diaphragm B away from the center block while pulling diaphragm A to the center block. Diaphragm B is now on its discharge stroke. These same hydraulic forces lift the discharge valve ball off its seat, while the opposite discharge valve ball is forced onto its seat, forcing fluid to flow through the pump discharge. Atmospheric pressure forces fluid into the inlet manifold of the pump. The inlet valve ball is forced off its seat allowing the fluid being pumped to fill the liquid chamber.



**Figure 3:** At completion of the stroke, the air valve again redirects air to the back side of diaphragm A, which starts diaphragm B on its exhaust stroke. As the pump reaches its original starting point, each diaphragm has gone through one exhaust and one discharge stroke. This constitutes one complete pumping cycle. The pump may take several cycles to completely prime depending on the conditions of the application.

## DIMENSIONAL DRAWINGS



## DIMENSIONS

ITEM	METRIC (mm)	STANDARD (inch)
A	267	10.5
B	36	1.4
C	137	5.4
D	254	10.0
E	279	11.0
F	28	1.1
G	97	3.8
H	76	3.0
J	185	7.3
K	211	8.3
L	173	6.8
M	107	4.2
N	127	5.0
P	8	0.3
R	33	1.3

BSPT threads available.

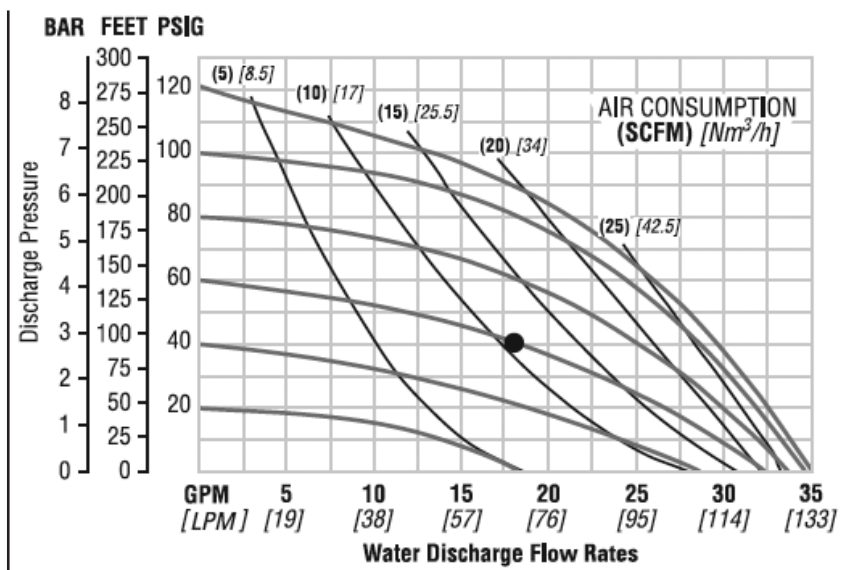
## PERFORMANCE NTG25 METAL RUBBER-FITTED

Height..... 279 mm (11.0")  
 Width..... 267 mm (10.5")  
 Depth..... 185 mm (7.3")  
 Est. Ship Weight..... Aluminum 12 kg (26 lbs)  
 316 S.S. 11.34 kg (25 lbs)  
 Air Inlet..... 6 mm (1/4")  
 Inlet..... 25 mm (1")  
 Outlet..... 19 mm (3/4")  
 Suction Lift..... 5.18 m Dry (17')  
 9.45 m Wet (31')  
 Displacement/Stroke..... 0.41 l (0.105 gal.)<sup>1</sup>  
 Max. Flow Rate..... 132 lpm (35 gpm)  
 Max. Size Solids..... 3.2 mm (1/8")

<sup>1</sup>Displacement per stroke was calculated at 4.8 bar (70 psig) air inlet pressure against a 2 bar (30 psig) head pressure.

**Example:** To pump 68.1 lpm (18.0 gpm) against a discharge pressure head of 2.7 bar (40 psig) requires 4.1 bar (60 psig) and 18.7 Nm<sup>3</sup>/h (11 scfm) air consumption. (See dot on chart.)

**Caution:** Do not exceed 8.6 bar (125 psig) air supply pressure.



Flow rates indicated on chart were determined by pumping water.

For optimum life and performance, pumps should be specified so that daily operation parameters will fall in the center of the pump performance curve.

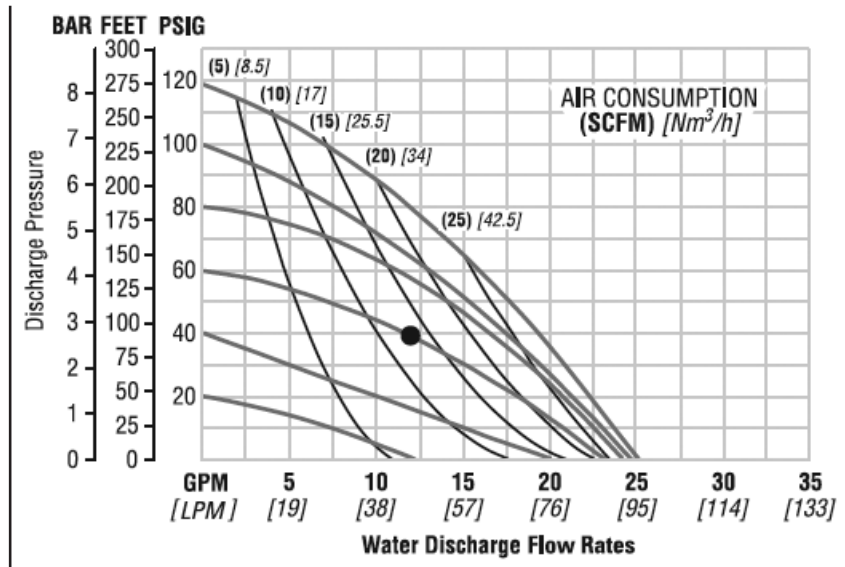
## PERFORMANCE NTG25 METAL PTFE-FITTED

Height.....279 mm (11.0")  
 Width.....267 mm (10.5")  
 Depth .....185 mm (7.3")  
 Est. Ship Weight.....Aluminum 12 kg (26 lbs)  
 Air Inlet......6 mm (1/4")  
 Inlet......25 mm (1")  
 Outlet .....19 mm (3/4")  
 Suction Lift.....1.83 m Dry (6')  
                           9.45 m Wet (31')  
 Displacement/Stroke .....0.19 l (0.050 gal.)<sup>1</sup>  
 Max. Flow Rate.....95 lpm (25 gpm)  
 Max. Size Solids.....3.2 mm (1/8")

<sup>1</sup>Displacement per stroke was calculated at 4.8 bar (70 psig) air inlet pressure against a 2 bar (30 psig) head pressure.

**Example:** To pump 45.4 lpm (12.0 gpm) against a discharge pressure head of 2.7 bar (40 psig) requires 4.1 bar (60 psig) and 21.1 Nm<sup>3</sup>/h (13 scfm) air consumption. (See dot on chart.)

**Caution:** Do not exceed 8.6 bar (125 psig) air supply pressure.



Flow rates indicated on chart were determined by pumping water.

For optimum life and performance, pumps should be specified so that daily operation parameters will fall in the center of the pump performance curve.

## SUGGESTED INSTALLATION

The suction pipe size should be at least 25mm (1") diameter or larger if highly viscous material is being pumped. The suction hose must be non-collapsible, reinforced type as the NTG25 is capable of pulling a high vacuum. Discharge piping should be at least 19mm (3/4"); larger diameter can be used to reduce friction losses. It is critical that all fittings and connections are airtight or a reduction or loss of pump suction capability will result.

Every pump location should have an air line large enough to supply the volume of air necessary to achieve the desired pumping rate.

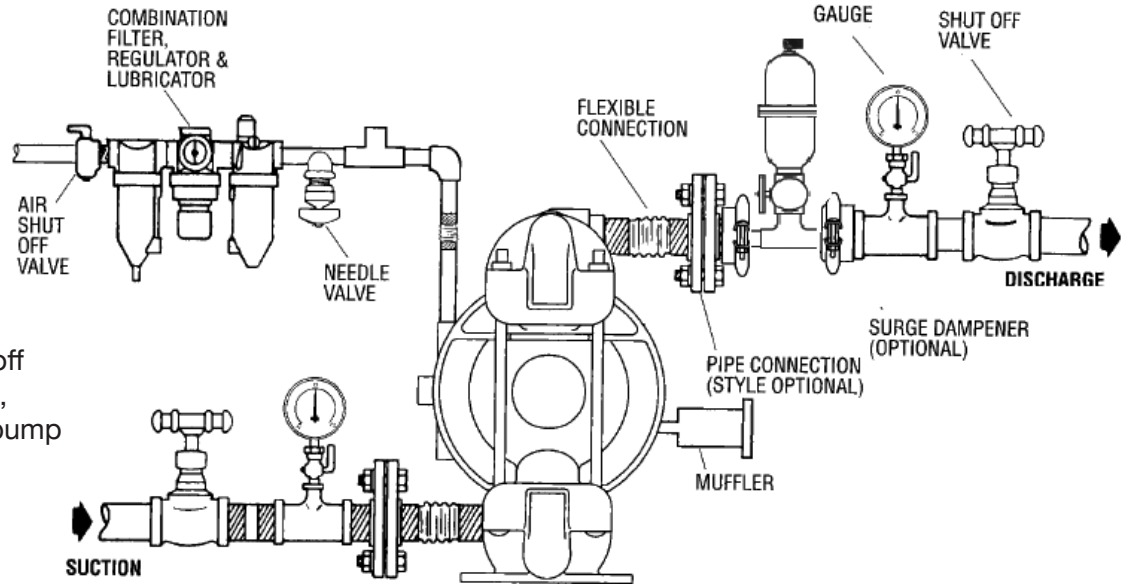
Unnecessary elbows, bends and fittings should be avoided. Pipe sizes should be selected so as to keep friction losses within practical limits. All piping should be supported independently of the pump.

Expansion joints can be installed to aid in absorbing the forces created by the natural reciprocating action of the pump. Flexible connections between the pump and rigid piping will also assist in minimizing pump vibration. A surge suppressor should be installed to protect the pump, piping and gauges from surges and water hammer.

When pumps are installed in applications involving flooded suction or suction head pressures, a gate valve should be installed in the suction line to permit closing of the line for pump service.

The NTG25 can be used in submersible applications only when both wetted and non-wetted portions are compatible with the material being pumped. If the pump is to be used in a submersible application, a hose should be attached to the pump's air exhaust and the exhaust air piped above the liquid level.

## SUGGESTED INSTALLATION



Note: In the event of a power failure, the shutoff valve should be closed, if the restarting of the pump is not desirable once power is regained.

## TROUBLESHOOTING

### ***Pump will not run or runs slowly.***

1. Check air inlet screen and air filter for debris.
2. Check for sticking air valve, flush air valve in solvent.
3. Check for worn out air valve. If piston face in air valve is shiny instead of dull, air valve is worn beyond working tolerances and must be replaced.
4. Check center block rings. If worn excessively, they will not seal and air will simply flow through pump and out air exhaust.
5. Check type of lubricant being used. ISO 15-5 wt. recommended.

### ***Pump runs but little or no product flows.***

1. Check for pump cavitation; slow pump speed down to match thickness of material being pumped.
2. Check for sticking ball valves. If material being pumped is not compatible with pump elastomers, swelling may occur.
3. Make sure all suction connections are air tight.

### ***Pump air valve freezes.***

Check for excessive moisture in compressed air.

### ***Air bubbles in pump discharge.***

1. Check for ruptured diaphragm.
2. Check for tightness for clamp bands, especially at intake manifold.

### ***Product comes out air exhaust.***

1. Check for diaphragm rupture.
2. Check tightness of piston plates to shaft.

### ***Pump rattles.***

Create false discharge head or suction lift.

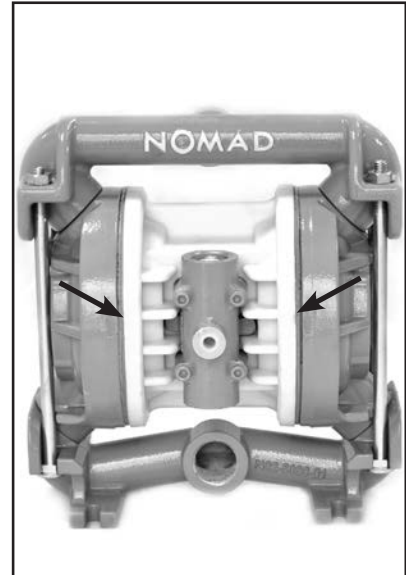
## DISASSEMBLY/REASSEMBLY

### Tools Required:

Adjustable Wrench

15 mm (9/16") Box Wrench

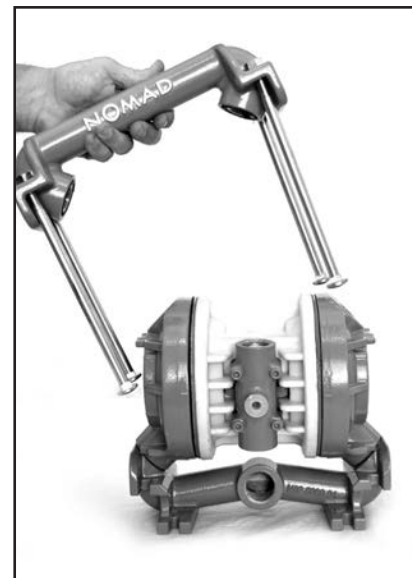
19 mm (3/4") Box Wrench Vise  
Equipped with soft jaws



**Step 1:** Before starting disassembly, mark a line from each liquid chamber to its corresponding air chamber. This line will assist in proper alignment during reassembly.



**Step 2:** Utilizing the 9/16" box wrench, start by removing the four long carriage bolts that secure the top and bottom manifolds to the center section.



**Step 3:** Remove the top manifold and lift the center section off the inlet manifold.





**Step 4:** Remove the discharge valve balls, seats and o-rings along with the valve seat, valve seat o-ring and valve ball from the discharge manifold and inspect for nicks, gouges, chemical attack or abrasive wear.



**Step 5:** Inspect the valve seat, valve seat o-ring, and valve ball from intake manifold. Check for nicks, gouges, chemical attack or abrasive wear.



**Step 6:** With the 3/4" box wrench or by rotating the diaphragm by hand, remove the diaphragm assembly.



**Step 7:** Due to varying torque values, one of the following two situations may occur: 1) The outer piston, diaphragm and inner piston remain attached to the shaft and the entire assembly can be removed from the center section. 2) The outer piston, diaphragm, inner piston and disc spring separate from the shaft which remains connected to the opposite side diaphragm assembly.

## DISASSEMBLY/REASSEMBLY



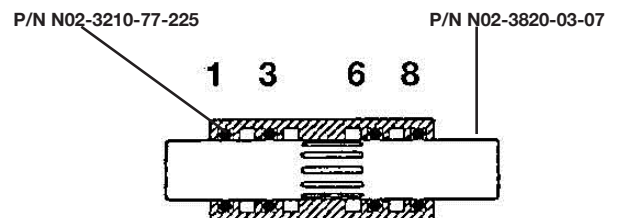
**Step 8:** To remove the diaphragm assembly from the shaft, secure shaft with soft jaws. Using an adjustable wrench, remove the diaphragm assembly from shaft.

## CENTER BLOCK/SEAL DISASSEMBLY

### Center Block Assembly:

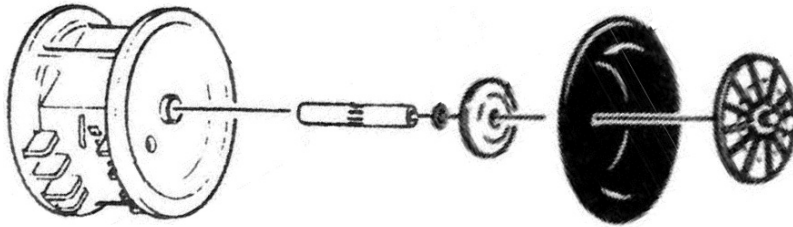
The pump's center block consists of a polypropylene or aluminum housing with a cast-in bronze bushing. The bushing has eight grooves cut on the inside diameter. There are four TRACKER™ seals that fit in these grooves. Since these TRACKER™ seals form a part of the shifting function of the pump, it is necessary that they be located in the proper grooves. When bushing wear becomes excessive, a new center block must be used.

Grooves in bushing which contain TRACKER™ seals

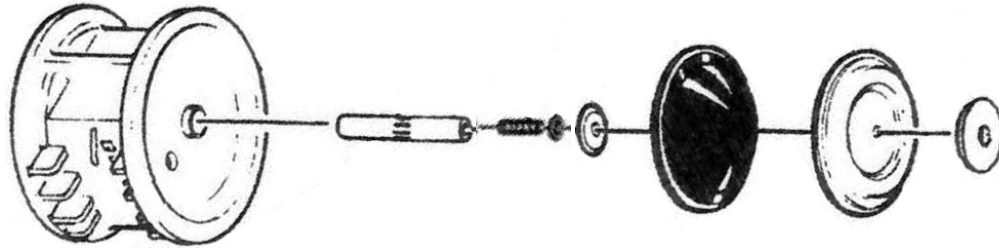


**ENHANCED CONFIGURATION**

**EXPLODED VIEW (RUBBER DIAPHRAGMS)**



**EXPLODED VIEW (PTFE DIAPHRAGMS)**



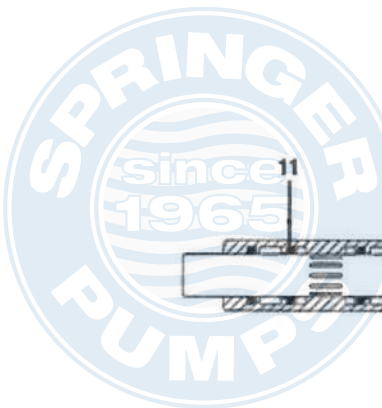
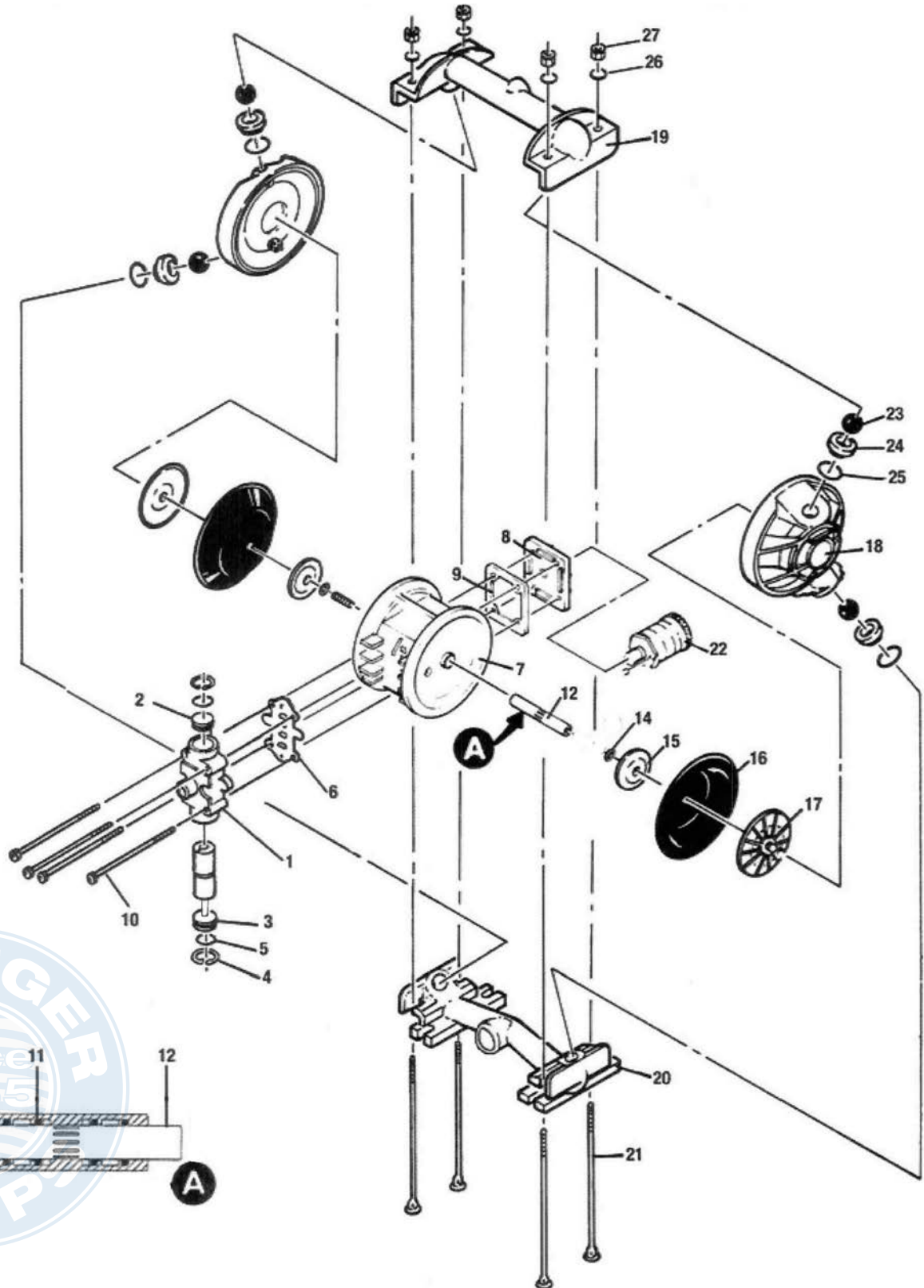
## NTG25 RUBBER-FITTED (ALUMINUM)

Item	Description	Qty.	Part Number
1	Air Valve Assembly	1	N02-2012-07
2	Air Valve End Cap w/Guide	1	N02-2332-01
3	Pressure Differential Cap	1	N02-2301-01
4	Air Valve Snap Ring	2	N02-2651-08
5	Air Valve Cap O-ring	2	N02-3201-52
6	Air Valve Gasket	1	N02-2600-52
7	Center Section	1	N02-3151-20-225
8	Muffler Plate	1	N02-3180-20
9	Muffler Plate Gasket	1	N02-3500-52-500
10	Air Valve Cap Screw 1/4" - 20 x 6 1/4"	4	N02-6000-08
	Hex Head Nut 1/4" -20 (Not Shown)	4	N02-6400-08
11	Center Block TRACKER™ Seal	4	N02-3210-77-225
12	Shaft	1	N02-3800-03-07
14	Disc Spring	2	N02-6802-08
15	Inner Piston	2	N02-3701-01
16	Diaphragm - Neoprene	2	N02-1010-51
17	Outer Piston	2	N02-4550-01
18	Liquid Chamber	2	N02-5000-01
19	Discharge Manifold	1	N02-5020-01
20	Inlet Manifold	1	N02-5080-01
21	Manifold Bolt 3/8" - 16 x 8-1/2"	4	N02-6080-08
22	Muffler	1	N02-3510-99
23	Valve Ball - Neoprene	4	N02-1080-51
24	Valve Seat - Aluminum	4	N02-1120-01
25	Valve Seat O-ring - Neoprene	4	N02-1200-51
26	Manifold Bolt Washer 3/8"	4	N02-6720-08
27	Manifold Bolt Nut 3/8" - 16	4	N02-6430-08

## NTG25 RUBBER-FITTED (316 S.S.)

10	Air Valve Cap Screw 1/4" = 20 x 2"	4	N02-6000-03
17	Outer Piston	2	N02-4550-03
18	Liquid Chamber	2	N02-5000-03
19	Discharge Manifold	1	N02-5020-03
20	Inlet Manifold	1	N02-5080-03
21	Manifold Bolt 3/8" - 16 x 8 1/2"	4	N02-6080-03
24	Valve Seat, S.S.	4	N02-1120-03
26	Manifold Bolt Washer 3/8"	4	N02-6720-03
27	Manifold Bolt Nut 3/8" - 16	4	N02-6430-03

## NTG25 RUBBER-FITTED



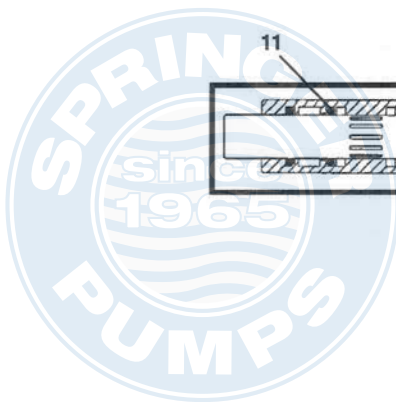
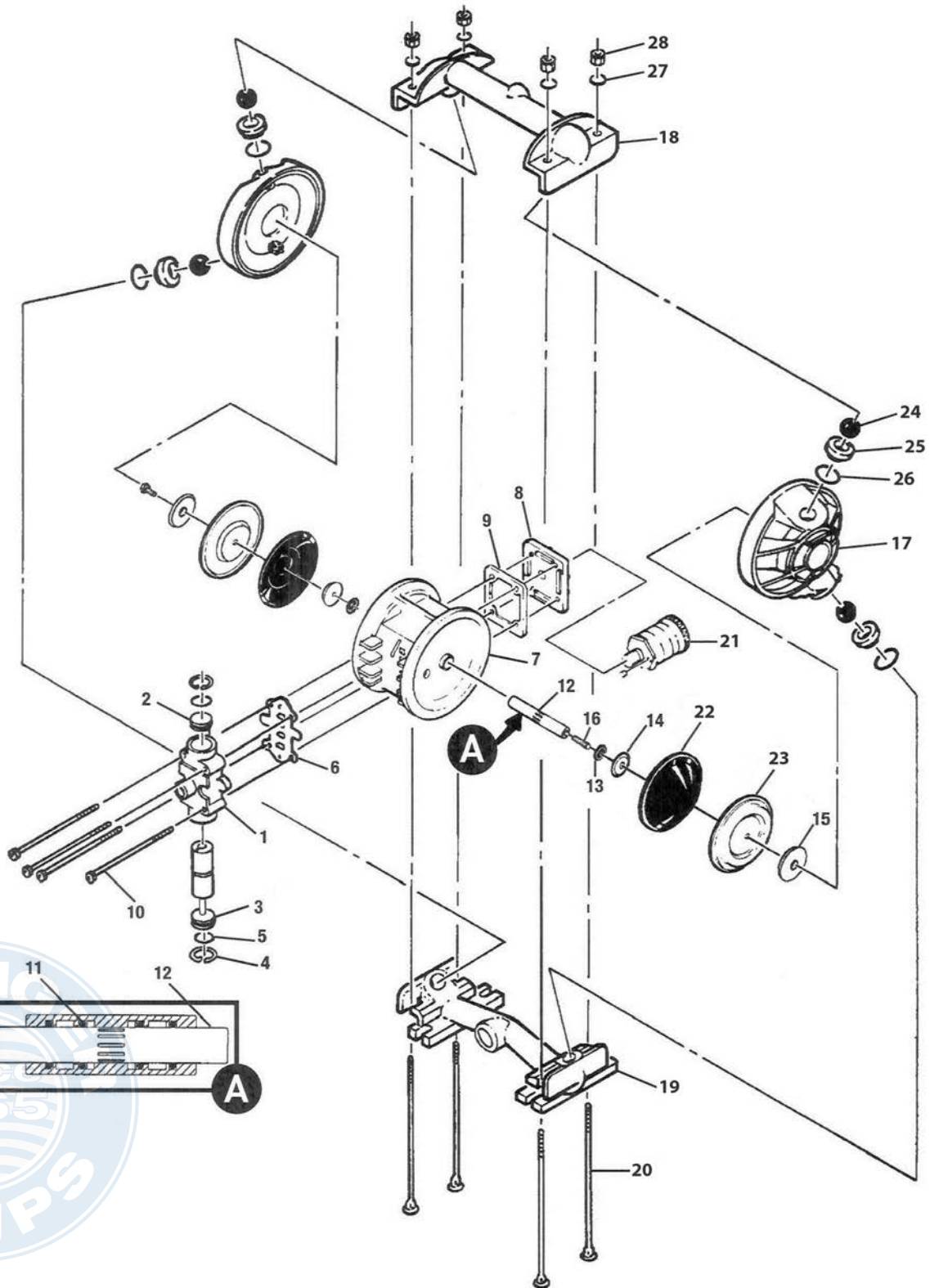
## NTG25 PTFE-FITTED (ALUMINUM)

Item	Description	Qty.	Part Number
1	Air Valve Assembly	1	N02-2012-07
2	Air Valve End Cap w/Guide	1	N02-2332-01
3	Pressure Differential Cap	1	N02-2301-01
4	Air Valve Snap Ring	2	N02-2651-01
5	Air Valve Cap O-ring	2	N02-3201-52
6	Air Valve Gasket	1	N02-2600-52
7	Center Section	1	N02-3151-20-225
8	Muffler Plate	1	N02-3180-20
9	Muffler Plate Gasket	1	N02-3500-52-500
10	Air Valve Cap Screw 1/4" - 20 x 6 1/4"	4	N02-6000-08
	Hex Head Nut 1/4" -20 (Not Shown)	4	N02-6400-08
11	Center Block TRACKER™ Seal	4	N02-3210-77-225
12	Shaft	1	N02-3820-09-07
13	Disc Spring	2	N02-6802-08
14	Inner Piston	2	N02-3750-01
15	Outer Piston	2	N02-4601-01
16	Shaft Stud	2	N02-6150-08
17	Liquid Chamber	2	N02-5000-01
18	Discharge Manifold	1	N02-5020-01
19	Inlet Manifold	1	N02-5080-01
20	Manifold Bolt 3/8" - 16 x 8-1/2"	4	N02-6080-08
21	Muffler	1	N02-3510-99
22	Back-up Diaphragm	2	N02-1060-51
23	Diaphragm - Teflon	2	N02-1010-55
24	Valve Ball - Teflon	4	N02-1080-55
25	Valve Seat - Aluminum	4	N02-1120-01
26	Valve Seat O-ring - Teflon	4	N02-1200-55
27	Manifold Bolt Washer 3/8"	4	N02-6720-08
28	Manifold Bolt Nut 3/8" - 16	4	N02-6430-08

## NTG25 PTFE-FITTED (316 S.S.)

10	Air Valve Cap Screw 1/4" - 20 x 2"	4	N02-6000-03
15	Outer Piston	2	N02-4600-03
17	Liquid Chamber	2	N02-5000-03
18	Discharge Manifold	1	N02-5020-03
19	Inlet Manifold	1	N02-5080-03
20	Manifold Bolt 3/8" - 16 x 8 1/2"	4	N02-6080-03
25	Valve Seat, S.S.	4	N02-1120-03
27	Manifold Bolt Washer 3/8"	4	N02-6720-03
28	Manifold Bolt Nut 3/8" - 16	4	N02-6430-03

## NTG25 PTFE-FITTED





A JDA Global Company

1351 Park Ave., Suite 104  
Redlands, CA USA 92373  
(909) 798-9532

N O M A D



NO BOUNDARIES™



Tel: 866-777-6060  
Fax: 866-777-6383

Springer Pumps, LLC

Website: [www.springerpumps.com](http://www.springerpumps.com)  
Int'l: +001 267 404 2910