

SLIDE RAIL COUPLING SRC-1¼

To be used with
2 HP grinder pumps



LOCATION

This SRC-1¼ is designed for wet wells, tanks, or lift stations where it is necessary to remove a pump from service and reinstall the pump without maintenance personnel entering the pit to unbolt the pump flanges.

FEATURES

- ▶ 1¼" NPT pump connection
- ▶ 2" NPT vertical discharge
- ▶ ¾" or 1" stainless steel guide rails
(provided by installer)
- ▶ Stress-free rail system
- ▶ Durable cast iron base and lift-out flange
- ▶ Stainless steel pump adapter and guide plate

STATIONARY ELBOW

Cast iron ASTM A-48 class 30

MOVABLE FITTING

Ductile iron ASTM A-536

GUIDERAIL CAP

Bracket: 304 stainless steel

Plugs: ductile iron ASTM A-536-84

HARDWARE

304 series stainless steel

O-RINGS

Buna-N, 70±5 Duro.

GASKETS

Rubber

PAINT

Air dry enamel, water based.

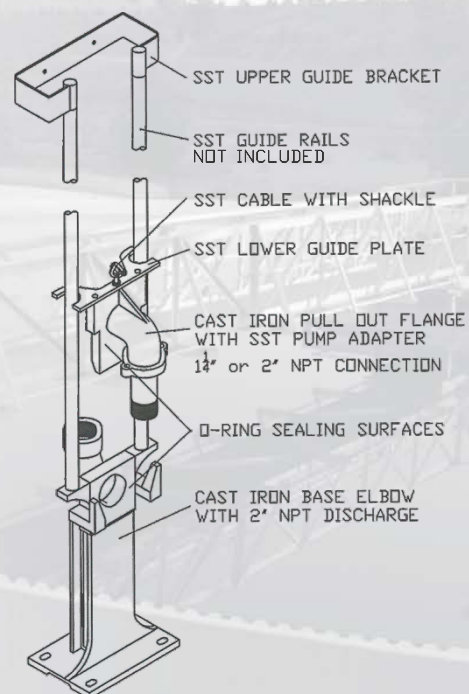

Last update: JUL/11/2023

SPECIFICATIONS

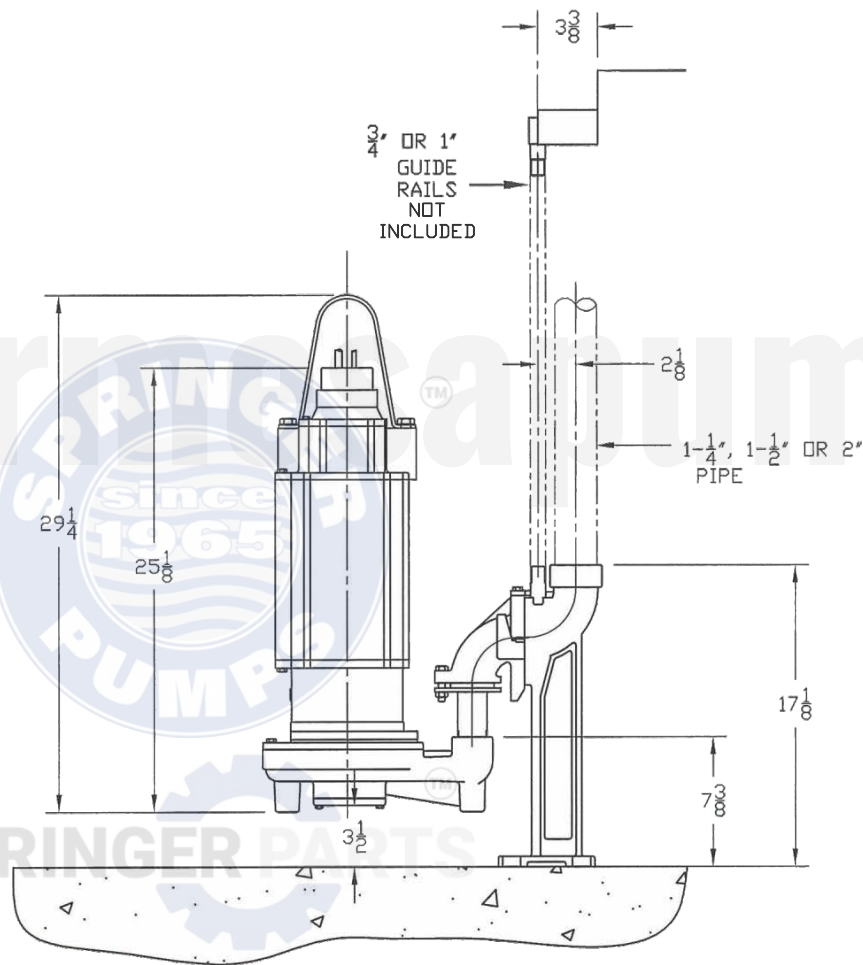
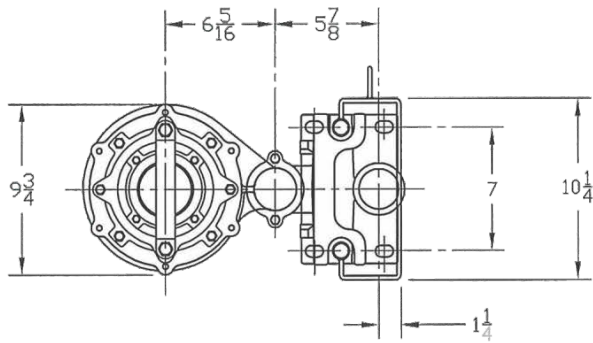

| MODEL | PART No. | SIZE | RAILS | COUPLING | WEIGHT (pounds) |
|--------|----------|--------|------------|------------------------|-----------------|
| SRC125 | 62170803 | 1 1/4" | 3/4" or 1" | w/ upper guide bracket | 45 |