



SUBMERSIBLE SOLIDS HANDLING PUMP

Series: **4SWM-DS**

20 - 50 HP @ 1750 RPM

Discharge: 4"

Spherical solids handling: 3"



DISCHARGE

4", 125 lb, horizontal flange, slotted to accommodate 100 mm ISO flange.

LIQUID TEMPERATURE

104°F (40°C) continuous

VOLUTE

Cast iron ASTM A-48 class 30

MOTOR HOUSING

Cast iron ASTM A-48 class 30

SEAL PLATE

Cast iron ASTM A-48 class 30

IMPELLER

Design: enclosed mono vane with pump-out vanes on back side. Dynamically balanced.

Material: ductile iron ASTM A-536, 65-45-12.

SHAFT

416 series stainless steel

HARDWARE

300 series stainless steel

O-RINGS

Buna-N

LIFTING BAIL

300 series stainless steel

MAX. SUBMERGENCE

66 ft (20 m)

PAINT

Epoxy

SEAL

Design: tandem, mechanical, in oil filled reservoir.

Material: inboard rotating faces, carbon; stationary faces, ceramic. Outboard rotating and stationary faces, silicon carbide. Buna-N elastomer and 300 series stainless steel hardware.

CORDENTRY

40 ft cord, epoxy sealed housing, with secondary pressure grommet for sealing and strain relief.

BEARINGS

Upper: ball, single row and oil lubricated, for radial load.

Lower: ball, double row and oil lubricated, for radial and thrust loads.

MOTOR

NEMA three phase 208/230 & 460 V, premium efficiency, oil-filled, squirrel cage induction, inverted duty rated. Class H insulation. Requires overload protection in control panel.

MOISTURE SENSOR

Normally open (N/O), requires relay and panel.

TEMPERATURE SENSOR

Normally closed (N/C), to be wired in series with control circuit.

OPTIONAL EQUIPMENT

Slide rail coupling, leg kit and seal material.

Last update: 05/10/2023

North America: 866 777 6060
Int'l: +1 267 404 2910

Springer Pumps
Springer Parts

www.springerpumps.com
www.springerparts.com

TECHNICAL DATA SHEET

SPECIFICATIONS

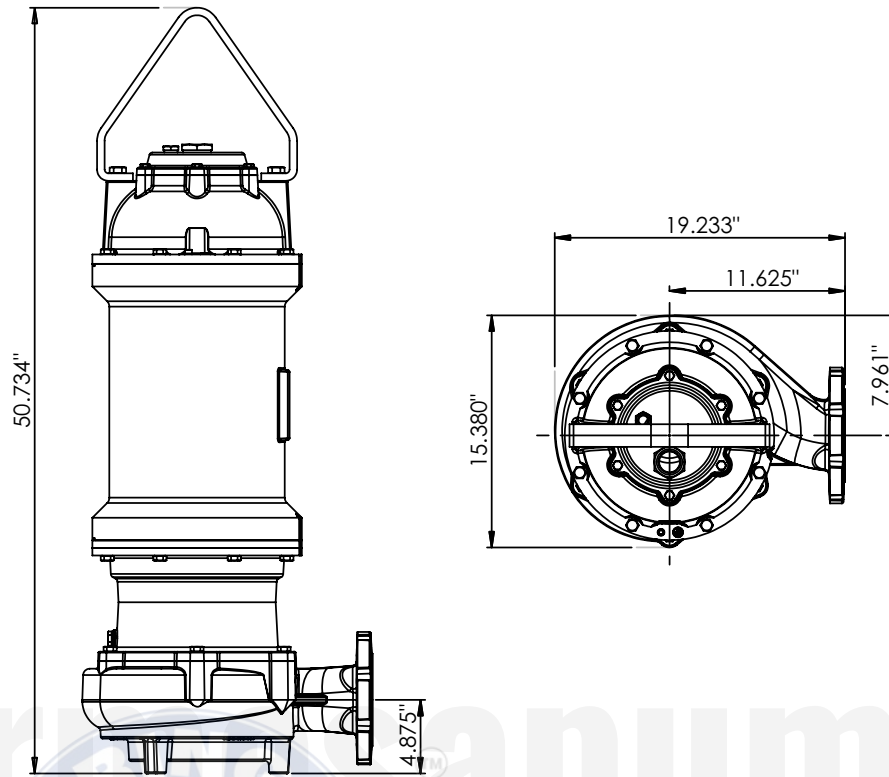

MODEL	PART No.	HP	PH	VOLTS	RPM (nom)	NEMA START CODE	FULL LOAD AMPS	SF	AMPS SF	FRAME	POWER CORD SIZE	WEIGHT (lb)
4SWM20034DS	62172019	20	3	208/230	1750	J	52.8/48	1.15	60.7/55	250	8/4	615
4SWM20044DS	62172020			460			24.1		27.3			
4SWM25034DS	62172021	25	3	208/230	1750	G	65/59	1.15	74.8/67.8	250	8/4	633
4SWM25044DS	62172022			460			29.5		34			
4SWM30034DS	62172023	30	3	208/230	1750	E	93.4/82.3	1.15	107/94	250	8/4	653
4SWM30044DS	62172024			460		F	46.7		53			
4SWM40044DS	62172025	40	3	460	1750	E	48	1.15	55.2	250	8/4	683
4SWM50044DS	62172026	50	3	460	1750	F	65	1.15	74.8	320	2/3	760

Note: Seal moisture and temperature sensor cord in all models size 18/5.

IMPORTANT!

1. Never use this pump to handle explosive liquids.
2. This pump is not approved to be used in swimming pools, recreational installations or any application where human contact may be common.
3. Moisture and temperature sensors must be connected to validate the warranty.
4. This pump is not appropriate for those applications specified as class 1 division 1 hazardous locations.

North America: 866 777 6060
Int'l: +1 267 404 2910

Springer Pumps
Springer Parts

barmesapumps.com/US
www.springerpumps.com
www.springerparts.com



PERFORMANCE CURVES

Submersible Solids

Handling Pump

Series: **4SWM-DS @ 1750 RPM**

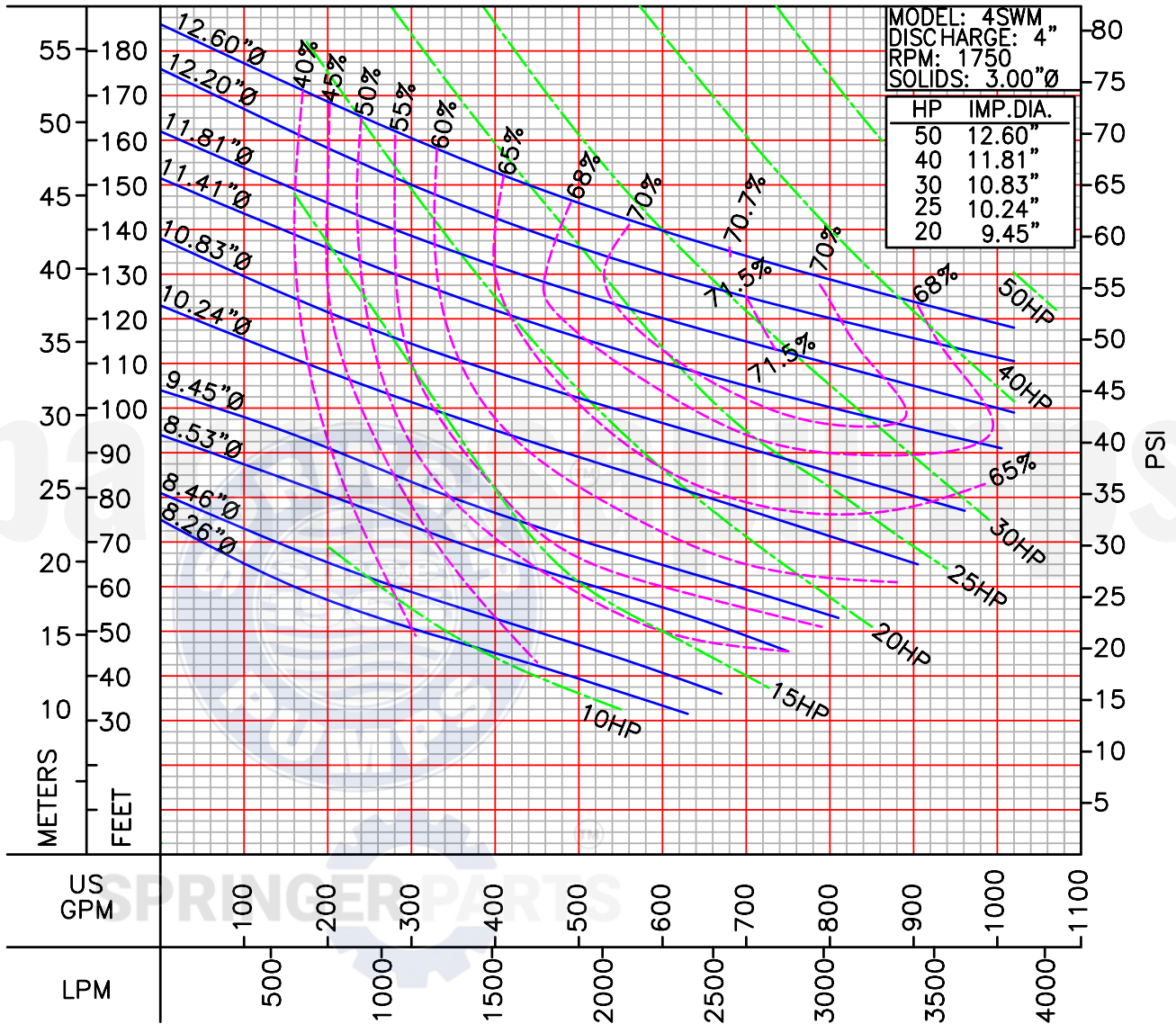

LIQUID: WATER
SPECIFIC GRAVITY: 1.00

TEMPERATURE: 70° F (21° C)
MAXIMUM DIA. SOLIDS: 3.00"Ø

barmesapumps.com/US

North America: 866 777 6060
Int'l: +1 267 404 2910

Springer Pumps
Springer Parts

www.springerpumps.com
www.springerparts.com