



# SUBMERSIBLE SOLIDS HANDLING PUMP

Series: 3BWSE-DS  
2 - 5 HP / 1750 RPM  
Discharge: 3"  
Spherical solids handling: 2½"



## DISCHARGE

3", 125lb, flange horizontal.

## LIQUID TEMPERATURE

104 °F (40 °C) continuous, 140 °F (60 °C) intermittent operation.

## VOLUTE

Cast iron ASTM A-48 class 30

## MOTOR HOUSING

Cast iron ASTM A-48 class 30

## SEAL PLATE

Cast iron ASTM A-48 class 30

## IMPELLER

**Design:** 2 vane, semi-open, with vanes on back side.

**Material:** cast iron ASTM A-48 class 30

## SHAFT

416 series stainless steel

## SQUARE RINGS

Buna-N

## PAINT

Air dry enamel, water based.

## SEAL

**Design:** dual, mechanical, oil filled chamber.

**Material:** silicon carbide with Viton type 01 outer seal, carbon ceramic with Buna-N type 01 inner seal, with stainless steel hardware.

## HARDWARE

300 series stainless steel

## CORD ENTRY

40 ft of cord, epoxy sealed housing with secondary pressure grommet for sealing and strain relief.

## MOTOR

NEMA B, three-phase and single-phase with permanent split capacitor, 230 & 460 volts, 60 Hz, 1750 RPM, oil filled, with class F insulation. Requires overload protection to be included in control panel.

## OPTIONAL EQUIPMENT

Additional cord, tungsten carbide seal, slide rail coupling (SRC-3).

Last update: DIC/5/2023

North America: 866 777 6060  
Int'l: +1 267 404 2910

Springer Pumps  
Springer Parts

[www.springerpumps.com](http://www.springerpumps.com)  
[www.springerparts.com](http://www.springerparts.com)

TECHNICAL DATA SHEET

# SPECIFICATIONS

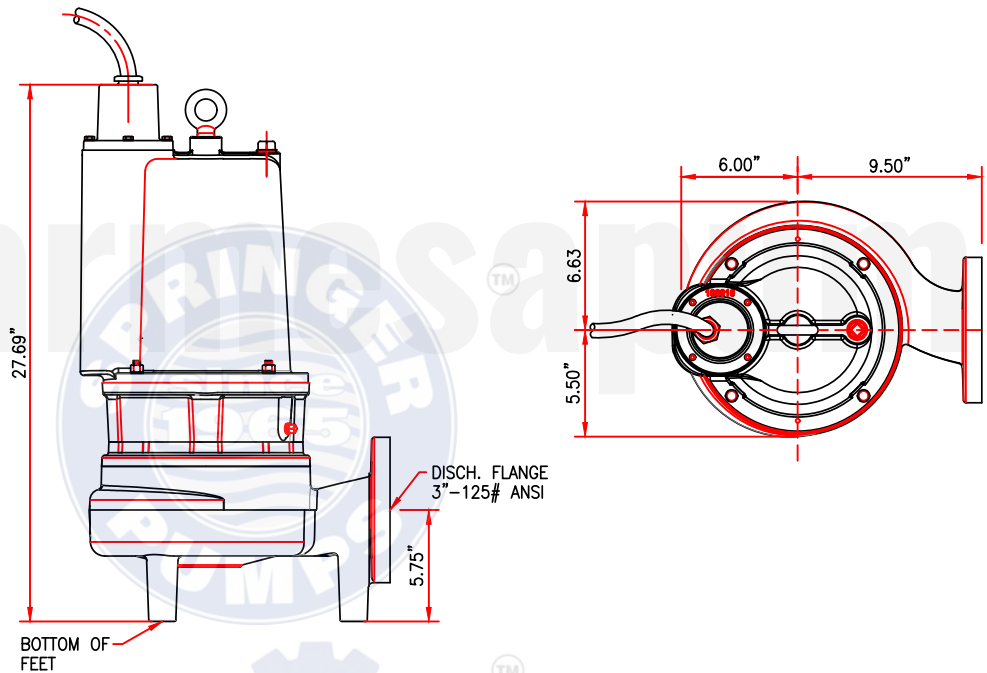
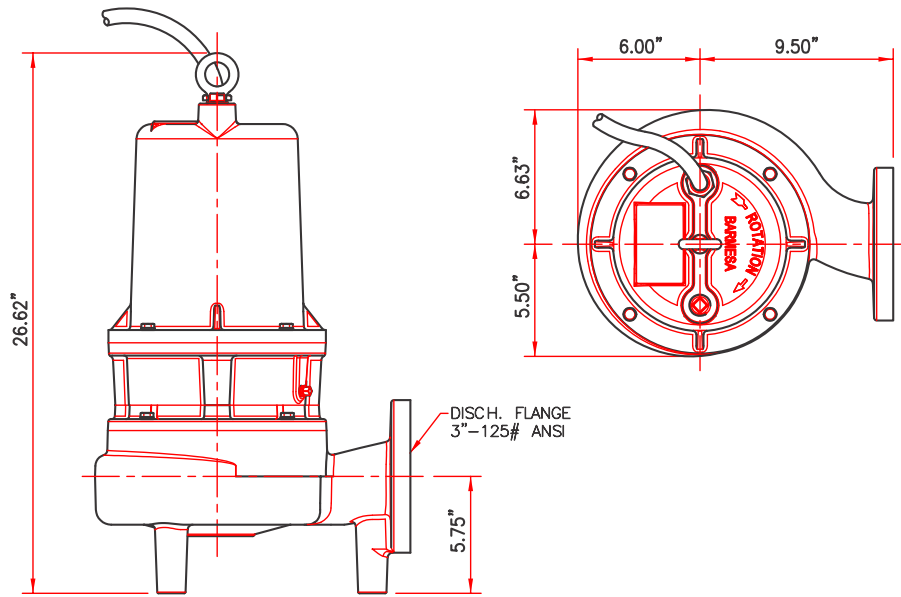

MODEL	PART No.	HP	V	PH	RPM (Nominal)	MAX AMPS	LOCKED ROTOR AMPS	NEMA CODE	CORD SIZE	CORD TYPE	WEIGHT (pounds)
3BWSE202DS	62170169	2	230	1	1750	18	72.3	C	10/3	STOW	225
3BWSE203DS	62170161	2	208/230	3	1750	15.8/14.3	40	F	10/4	STOW	194
3BWSE204DS	62170162	2	460	3	1750	7.2	20	F	10/4	STOW	194
3BWSE302DS	62170167	3	230	1	1750	20.8	83.2	C	10/3	STOW	225
3BWSE303DS	62170163	3	208/230	3	1750	17.3/15.9	49.5	H	10/4	STOW	201
3BWSE304DS	62170164	3	460	3	1750	8	24.8	H	10/4	STOW	201
3BWSE503DS	62170165	5	208/230	3	1750	24.2/22.1	63.6	E	10/4	STOW	205
3BWSE504DS	62170166	5	460	3	1750	11	31.8	E	10/4	STOW	205

### IMPORTANT!

1. Never use this pump to handle explosive liquids.
2. This pump is not approved to be used in swimming pools, recreational installations or any application where human contact may be common.
3. Pump may be operated "dry" for extended periods without damage to motor and/or seals.

[barmesapumps.com/US](http://barmesapumps.com/US)

North America: 866 777 6060  
Int'l: +1 267 404 2910

Springer Pumps  
Springer Parts

[www.springerpumps.com](http://www.springerpumps.com)  
[www.springerparts.com](http://www.springerparts.com)

## PERFORMANCE CURVE WASTEWATER SUBMERSIBLE PUMP

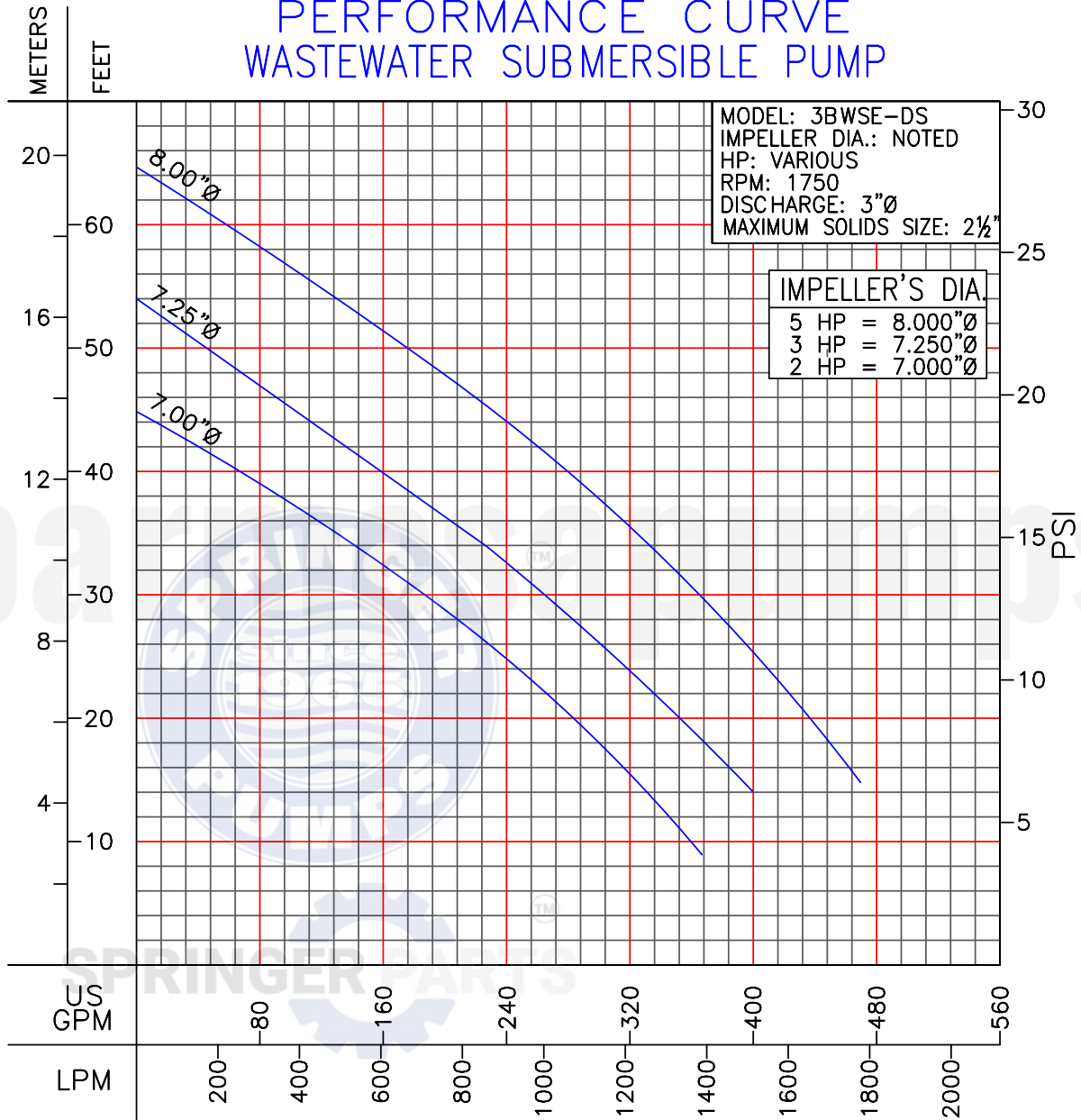

**IMPORTANT!**

4. Testing is performed with water specific gravity of 1.0 @ 68°F (20°C); other fluids may vary performance.