

12 Volt DC Aluminum Submersible Pump



Model 5891-DC

- **Aluminum Construction with Cast Aluminum Impeller**
- **1/3 HP, 12 Volt DC 30 Amp Motor**
- **1-1/2" NPT Discharge**
- **Buna-N Mechanical Seal with Carbon and Ceramic Faces**
- **Operates Approximately 60 Minutes on Fully Charged 55 Amp-Hour Battery**
- **Built-In Carry Handle**
- **Steel Strainer Built into Pump**
- **Overload Protection**
- **On/Off Switch**
- **Maximum Flow 43 GPM**



Model 5890-DC



5890-90

The AMT Submersible 12 Volt DC pump is designed for use in dewatering applications where limited or no electricity is present and for emergency back-up during power failure. The light weight pump is constructed of aluminum body with cast aluminum impeller. Unit comes assembled with 30 foot power cord, which has battery clips for easy attachment to 12 volt battery. Pumps are designed to handle liquids with solid content or dissolved solids and debris.

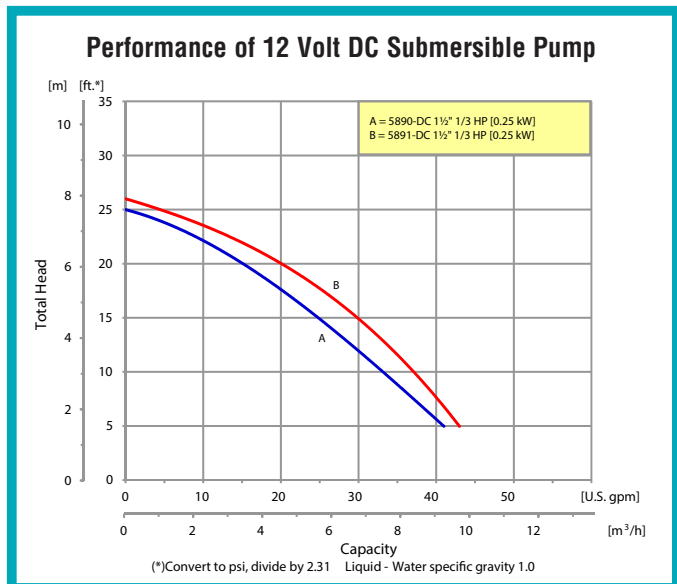

400 Spring Street • Royersford, PA 19468 USA

www.amtpump.com • 888-amt-pump (268-7867)

For use with nonflammable liquids compatible with pump component materials. Viton® is registered trademarks of E. I. DuPont.

SUB-7

Tel: 866-777-6060
Fax: 866-777-6383

Springer Pumps, LLC

Website: www.springerpumps.com
Int'l: +001 267 404 2910



12 Volt DC Submersible Pump

Pump Dimensional & Specification Data

Model	Description/Type of Pump	HP	Voltage @ 60 Hz	Full Load Amps	DIS*	Seal Type & Elastomer	Motor Enclosure	A Suction Strainer	H	W	Ship Wt. (Lbs.)
5890-DC	Electric Submersible Pump	1/3	12V DC	30	1.5	Buna Carbon Ceramic	Aluminum	0.38/[0.9] Dia. Holes Located On 0.5/[1.2] Staggered Centers.	22.4 [56.9]	8.8 [22.3]	35
5891-DC	Electric Submersible Pump	1/3	12V DC	26	1.5	Buna Carbon Ceramic	Aluminum		19.1 [48.5]	9.8 [24.9]	40
5890-90	Optional Carrying Case										14

(* Standard NPT (Female) Pipe Thread.

(**) Stainer defines maximum solids handling.

NOTE: All dimensions are in inches (centimeters) and have a tolerance of $\pm 1/8$ ".

NOTE: Electric Supply for ALL motors must be within $\pm 10\%$ of nameplate voltage (Ex: 230V = 203 to 253)

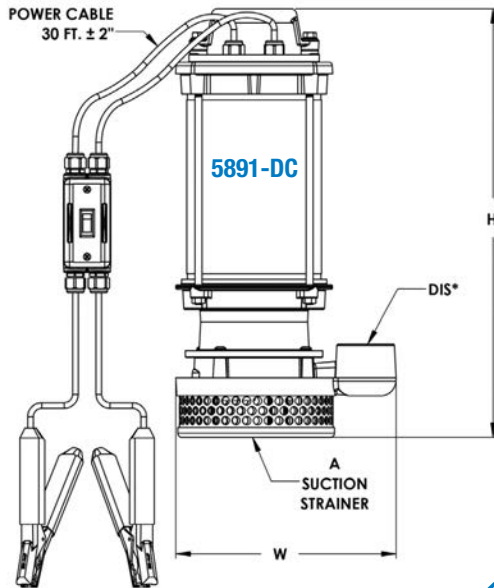

**NEW DESIGN FOR 2019
MODEL # 5891-DC**

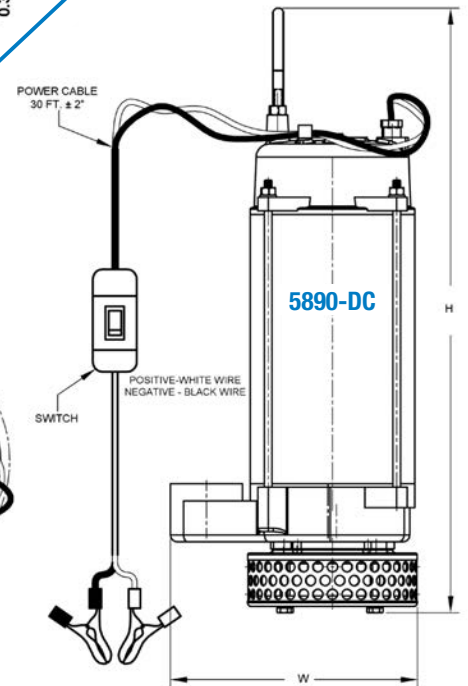
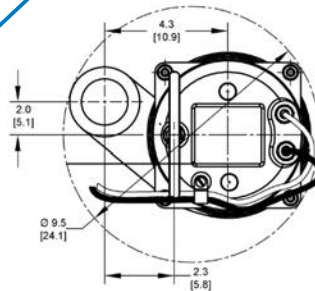
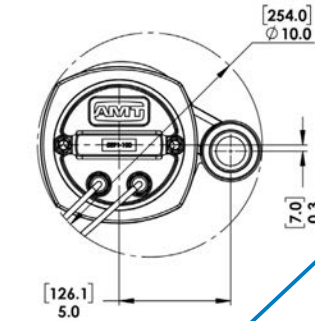

Standard Features

- Aluminum Construction with Cast Iron Impeller
- 1/3 HP, 12 Volt DC 30 Amp Motor
- 30 Ft. Insulated (PVC) Conductor Cable with Battery Clips
- Built-in Carry Handle
- On/Off Switch
- Maximum Temperature 104° F
- 1-1/2" NPT (Female) Discharge
- Steel Strainer Built into Pump
- Buna-N Mechanical Seal with Carbon and Ceramic Faces
- Overload Protected
- Stock Availability on this Model
- QSP - Quick Ship Pump



Manufacturer of AMT & IPT Pumps

400 Spring Street • Royersford, PA 19468 USA

www.amtpump.com • 888-amt-pump (268-7867)

The Gorman-Rupp Company reserves the right to discontinue any model or change specifications at any time without incurring any obligation.
©2012 American Machine and Tool Company. All rights reserved.



GORMAN-RUPP®

1219

SUB-8

Tel: 866-777-6060
Fax: 866-777-6383

Springer Pumps, LLC

Website: www.springerpumps.com
Int'l: +001 267 404 2910