

## Stainless Steel Straight Centrifugal Pumps

- **Stainless Steel Construction with Viton® Mechanical Seal and O-Ring**
- **Investment Cast Stainless Steel Impeller**
- **High Head and High Volume Models**
- **Maximum Temperature 200° F**
- **Maximum Flow 156 GPM**
- **Maximum Head 130 Ft.**
- **Chemical Resistant Design**
- **Discharge Port Rotates in 90° Increments**
- **547 Series: 3/4" x 1/2" Ports and 1-1/4" x 3/4" Ports**
- **548 & 553 Series: 1-1/2" x 1-1/4"**
- **549 Series: 2" x 1-1/2" Ports**

High Head Pump

High Volume Pump

AMT Stainless Steel Solids Handling End Suction Centrifugal pumps are designed for continuous duty high flow and high pressure applications including: chemical processing, liquid transfer, cooling, pressure boosting, circulating, dirty water and applications requiring contaminant free pumping. Constructed of rugged deep drawn stainless steel for durability and corrosion resistance. Investment cast stainless steel closed impeller for enhanced performance, high efficiencies and handles a maximum of 1/8" diameter solids.

All models include Viton® Type 21 mechanical seals and O-rings which offer a broad range of chemical compatibility. Cast iron motor adapter provides a positive and rigid mounting to motor. Pumps include Totally Enclosed Fan Cooled (TEFC) motors or Open Drip Proof (ODP) motors by special quote. **Pumps are not self-priming and require flooded suction.**

Performance of Stainless Steel Straight Centrifugal Pumps

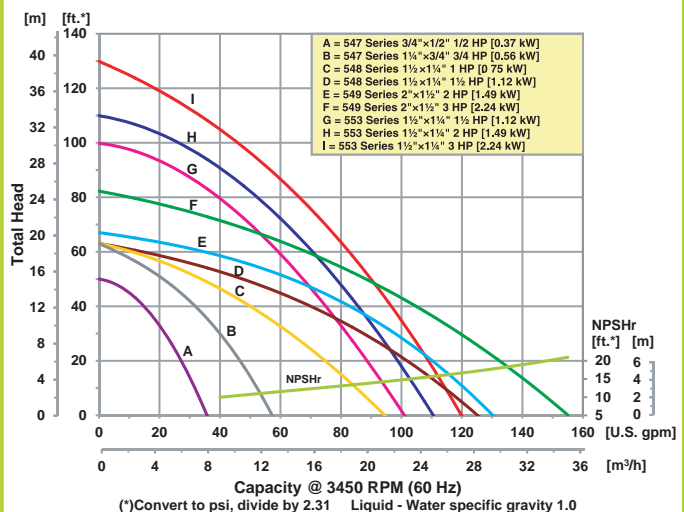

A Gorman-Rupp Company

400 Spring Street • Royersford, PA 19468 USA

[www.amtpump.com](http://www.amtpump.com) • 888-amt-pump (268-7867)

For use with nonflammable liquids compatible with pump component materials. Viton® and Teflon® are registered trademarks of E. I. DuPont.

STE-13

Tel: 866-777-6060  
Fax: 866-777-6383

Springer Pumps, LLC

Website: [www.springerpumps.com](http://www.springerpumps.com)  
Int'l: +001 267 404 2910

## High Volume Pump Dimensional & Specification Data

Model	Curve	HP	PH	ENC	Voltage @ 60 Hz +	Full Load Amps	SUC*	DIS*	A**	B**	C**	D	E	F	L**	W	H	Ship Wt. (Lbs.)
5475-98	A	1/2	1	ODP	115/230	8/4	3/4	1/2	N/A	5.1 [13.0]	6.4 [16.3]	N/A	2.1 [5.5]	4.1 [10.5]	12.7 [32.2]	8.2 [20.8]	7.8 [14.6]	23
5471-98	B	3/4	3	TEFC	115/230	9/5	1 1/4	3/4	5.4 [13.8]	5.1 [13.0]	6.4 [16.3]	N/A	2.1 [5.5]	4.1 [10.5]	13.7 [34.8]	10.2 [26.0]	7.8 [14.6]	38
5473-98					230/460	3/2			5.4 [13.8]	N/A	6.4 [16.3]	N/A	2.1 [5.5]	4.1 [10.5]	13.2 [33.5]	10.2 [26.0]	7.8 [14.6]	31
5481-98	C	1	3	TEFC	115/230	12/6	1 1/2	1 1/4	5.4 [13.8]	5.1 [13.0]	6.0 [15.4]	N/A	1.8 [4.6]	4.0 [10.2]	13.6 [34.5]	10.6 [26.9]	7.8 [14.6]	40
5483-98					230/460	4/2			5.4 [13.8]	N/A	6.0 [15.4]	N/A	1.8 [4.6]	4.0 [10.2]	12.2 [30.1]	10.6 [26.9]	7.8 [14.6]	35
5485-98	D	1 1/2	3	TEFC	115/230	18/9	1 1/2	1 1/4	5.4 [13.8]	5.1 [13.0]	6.0 [15.4]	N/A	1.8 [4.6]	4.0 [10.2]	14.1 [35.8]	10.6 [26.9]	7.8 [14.6]	49
5487-98					230/460	5/3			5.4 [13.8]	N/A	6.0 [15.4]	N/A	1.8 [4.6]	4.0 [10.2]	13.9 [35.3]	10.6 [26.9]	7.8 [14.6]	38
5491-98	E	2	3	TEFC	115/230	22/11	2	1 1/2	5.4 [13.8]	5.0 [12.7]	6.1 [15.6]	N/A	1.8 [4.6]	4.0 [10.2]	14.9 [37.8]	10.6 [26.9]	7.8 [14.6]	51
5493-98					230/460	6/3			5.4 [13.8]	N/A	6.1 [15.6]	N/A	1.8 [4.6]	4.0 [10.2]	14.5 [36.8]	10.6 [26.9]	7.8 [14.6]	44
5495-98	F	3	1	TEFC	230	16	2	1 1/2	5.4 [13.8]	5.0 [12.7]	6.1 [15.6]	N/A	1.8 [4.6]	4.0 [10.2]	15.4 [39.1]	10.6 [26.9]	7.8 [14.6]	60
5497-98					230/460	8/4			5.4 [13.8]	N/A	6.1 [15.6]	N/A	1.8 [4.6]	4.0 [10.2]	15.0 [38.1]	10.6 [26.9]	7.8 [14.6]	48

### High Volume

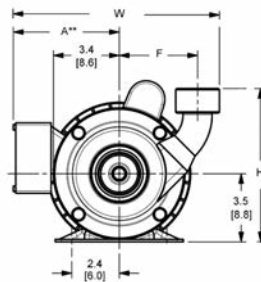
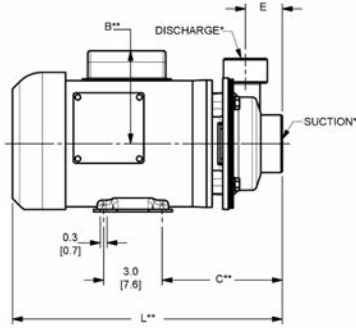

### High Head

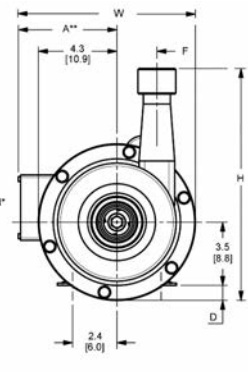
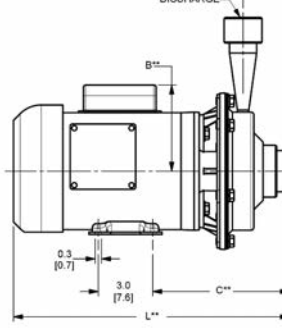

## High Head Pump Dimensional & Specification Data

Model	Curve	HP	PH	ENC	Voltage @ 60 Hz +	Full Load Amps	SUC*	DIS*	A**	B**	C**	D	E	F	L**	W	H	Ship Wt. (Lbs.)
5539-98	G	1 1/2	3	TEFC	115/230	18/9	1 1/2	1 1/4	5.4 [13.8]	5.1 [13.0]	7.5 [19.1]	0.8 [2.1]	2.5 [6.5]	2.2 [5.6]	15.5 [39.4]	9.8 [24.8]	12.8 [27.2]	54
5538-98					230/460	5/3			5.4 [13.8]	N/A	7.5 [19.1]	0.8 [2.1]	2.5 [6.5]	2.2 [5.6]	15.3 [38.8]	9.8 [24.8]	12.8 [27.2]	44
5535-98	H	2	3	TEFC	115/230	22/11	1 1/2	1 1/4	5.4 [13.8]	5.1 [13.0]	7.5 [19.1]	0.8 [2.1]	2.5 [6.5]	2.2 [5.6]	16.3 [41.6]	9.8 [24.8]	12.8 [27.2]	56
5537-98					230/460	6/3			5.4 [13.8]	N/A	7.5 [19.1]	0.8 [2.1]	2.5 [6.5]	2.2 [5.6]	15.8 [40.1]	9.8 [24.8]	12.8 [27.2]	49
5531-98	I	3	1	TEFC	230	16	1 1/2	1 1/4	5.4 [13.8]	5.1 [13.0]	7.5 [19.1]	0.8 [2.1]	2.5 [6.5]	2.2 [5.6]	16.8 [42.6]	9.8 [24.8]	12.8 [27.2]	65
5533-98					230/460	8/4			5.4 [13.8]	N/A	7.5 [19.1]	0.8 [2.1]	2.5 [6.5]	2.2 [5.6]	16.3 [41.6]	9.8 [24.8]	12.8 [27.2]	53

(\*) Standard NPT (Female) pipe thread.

(\*\*) This dimension may vary due to motor manufacturer's specifications.

(+) 3-Phase motors can also operate on 50 Hz. (This will change full load amps, service factor and RPM)

NOTE: Dimensions are in inches (centimeters) and have a tolerance of  $\pm 1/4"$ .

NOTE: Electric supply for ALL motors must be within  $\pm 10\%$  of nameplate voltage rating (e.g. 230V  $\pm 10\%$  = 207 to 253).

Maximum Solids Handling Capacity: 1/8" Diameter

## Standard Features

- Stainless Steel Construction
- Viton® Mechanical Seal and O-ring, Optional Buna-N Seal and O-ring Available
- Investment Cast Stainless Steel Impeller
- Cast Iron Motor Adapter Provides Rigid Mounting
- AeroSpace Fusion Welding
- Stainless Steel Motor Shaft & Hardware
- 1/2 to 3 HP NEMA 56J TEFC Single & Three Phase Motors
- NEMA Base Mounted Motors
- Maximum Working Pressure 150 PSI
- Maximum Temperature 200° F
- QSP – Quick Ship Pump for Many Models

Hazardous Duty/Explosion Proof motors available from stock ranging from 1 to 10 HP; CALL FOR QUOTATION & LEAD TIME!