

Self-Priming Sprinkler/Booster Pumps

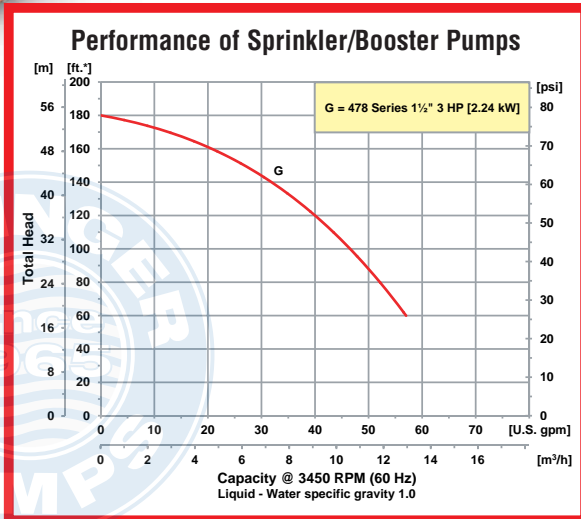

Model 3790-95

- **Cast Iron Construction with 300 Series Investment Cast Stainless Steel Impellers**
- **Buna-N Mechanical Seal and O-Ring**
- **Optional Viton® Seal, Check Valve and O-Ring Available on Single Stage Models**
- **1-1/2" or 2" NPT Ports Sizes**
- **Maximum Temperature 180° F**
- **Maximum Flow 157 GPM**
- **Maximum Head 180 Ft.**
- **Self-Priming to 20 Ft.**
- **Single Stage (379/365 Series) Two Stage (478 Series) Construction**
- **Single Stage Models Feature Removable Dual Volute Design**
- **Available with 3/4 to 7-1/2 HP Single or Three Phase Motors**

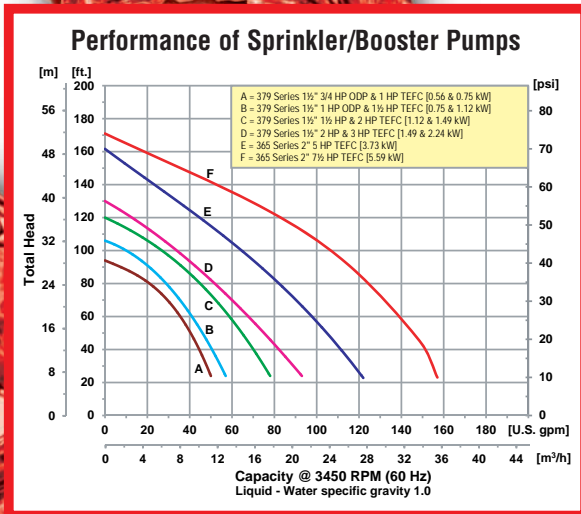

AMT Sprinkler/Booster pumps feature 300 Series Investment cast stainless steel impellers for resistance against erosion caused by abrasive particles. All models self-prime to 20 feet. Single stage models feature dual volute design to reduce radial load on motor and a built-in check valve to ensure fast priming after initial liquid is added to the pump. Cast iron construction provides durability and low maintenance. Easy cleanout design includes replaceable dual volute/diffuser and casing o-ring for servicing. Two-stage models provide additional pressure in fractional horsepower sizes for multi-sprinkler head applications. Type 21 mechanical seals handle maximum working pressure to 150 PSI. Pumps are available from 3/4 to 7-1/2 HP with Open Drip Proof (ODP) or Totally Enclosed Fan Cooled (TEFC) motors.



400 Spring Street • Royersford, PA 19468 USA

www.amtpump.com • 888-amt-pump (268-7867)

For use with nonflammable liquids compatible with pump component materials. Viton® and Teflon® are registered trademarks of E. I. DuPont.

SPE-19

Pump Dimensional & Specification Data

Model	Curve	HP	PH	ENC	Voltage @ 60 Hz +	SUC*	DIS*	A	B	C	D	E	F	G	J	K	L**	W**	H	Ship Wt. (Lbs.)
3790-95	A	¾	1	ODP	115/230	1½	1½	2.2 [5.5]	2.1 [5.3]	2.9 [7.3]	4.4 [11.1]	4.7 [11.9]	3.1 [7.8]	6.2 [15.7]	0.5 [1.2]	0.7 [1.7]	18.1 [46.0]	8.0 [20.3]	9.1 [23.1]	66
379A-95		1	1	TEFC	115/230	1½	1½	2.2 [5.5]	2.1 [5.3]	2.9 [7.3]	4.4 [11.1]	4.7 [11.9]	3.1 [7.8]	6.2 [15.7]	0.5 [1.2]	0.7 [1.7]	18.6 [47.2]	9.3 [23.6]	9.1 [23.1]	67
379F-95		1	3	TEFC	230/460	1½	1½	2.2 [5.5]	2.1 [5.3]	2.9 [7.3]	4.4 [11.1]	4.7 [11.9]	3.1 [7.8]	6.2 [15.7]	0.5 [1.2]	0.7 [1.7]	17.1 [43.4]	9.3 [23.6]	9.1 [23.1]	63
3791-95	B	1	1	ODP	115/230	1½	1½	2.2 [5.5]	2.1 [5.3]	2.9 [7.3]	4.4 [11.1]	4.7 [11.9]	3.1 [7.8]	6.2 [15.7]	0.5 [1.2]	0.7 [1.7]	18.3 [46.4]	8.0 [20.3]	9.1 [23.1]	70
379B-95		1½	1	TEFC	115/230	1½	1½	2.2 [5.5]	2.1 [5.3]	2.9 [7.3]	4.4 [11.1]	4.7 [11.9]	3.1 [7.8]	6.2 [15.7]	0.5 [1.2]	0.7 [1.7]	19.1 [48.5]	9.3 [23.6]	9.1 [23.1]	77
379J-95		1½	3	TEFC	230/460	1½	1½	2.2 [5.5]	2.1 [5.3]	2.9 [7.3]	4.4 [11.1]	4.7 [11.9]	3.1 [7.8]	6.2 [15.7]	0.5 [1.2]	0.7 [1.7]	18.8 [47.7]	9.3 [23.6]	9.1 [23.1]	72
3792-95	C	1½	1	ODP	115/230	1½	1½	2.2 [5.5]	2.1 [5.3]	2.9 [7.3]	4.4 [11.1]	4.7 [11.9]	3.1 [7.8]	6.2 [15.7]	0.5 [1.2]	0.7 [1.7]	18.8 [47.7]	8.0 [20.3]	9.1 [23.1]	70
379C-95		2	1	TEFC	115/230	1½	1½	2.2 [5.5]	2.1 [5.3]	2.9 [7.3]	4.4 [11.1]	4.7 [11.9]	3.1 [7.8]	6.2 [15.7]	0.5 [1.2]	0.7 [1.7]	19.8 [50.3]	9.3 [23.6]	9.1 [23.1]	79
379E-95		2	3	TEFC	230/460	1½	1½	2.2 [5.5]	2.1 [5.3]	2.9 [7.3]	4.4 [11.1]	4.7 [11.9]	3.1 [7.8]	6.2 [15.7]	0.5 [1.2]	0.7 [1.7]	19.3 [49.0]	9.3 [23.6]	9.1 [23.1]	71
3793-95	D	2	1	ODP	115/230	1½	1½	2.2 [5.5]	2.1 [5.3]	2.9 [7.3]	4.4 [11.1]	4.7 [11.9]	3.1 [7.8]	6.2 [15.7]	0.5 [1.2]	0.7 [1.7]	18.8 [47.7]	8.0 [20.3]	9.1 [23.1]	79
379D-95		3	1	TEFC	230	1½	1½	2.2 [5.5]	2.1 [5.3]	2.9 [7.3]	4.4 [11.1]	4.7 [11.9]	3.1 [7.8]	6.2 [15.7]	0.5 [1.2]	0.7 [1.7]	20.3 [51.5]	9.3 [23.6]	9.1 [23.1]	87
379L-95		3	3	TEFC	230/460	1½	1½	2.2 [5.5]	2.1 [5.3]	2.9 [7.3]	4.4 [11.1]	4.7 [11.9]	3.1 [7.8]	6.2 [15.7]	0.5 [1.2]	0.7 [1.7]	19.8 [50.3]	9.3 [23.6]	9.1 [23.1]	76
3657-95	E	5	1	TEFC	230	2	2	3.7 [9.4]	2.1 [5.3]	5.5 [13.9]	4.5 [11.4]	4.7 [11.9]	3.1 [7.8]	15.9 [40.3]	0.4 [1.0]	0.4 [1.0]	27.4 [69.6]	13.4 [34.0]	10.0 [25.4]	165
3655-95		5	3	TEFC	230/460	2	2	3.7 [9.4]	2.1 [5.3]	5.5 [13.9]	4.5 [11.4]	4.7 [11.9]	3.1 [7.8]	15.9 [40.3]	0.4 [1.0]	0.4 [1.0]	25.0 [63.5]	12.3 [31.2]	10.0 [25.4]	157
3656-95	F	7½	3	TEFC	230/460	2	2	3.7 [9.4]	2.1 [5.3]	5.5 [13.9]	5.2 [13.2]	4.7 [11.9]	3.1 [7.8]	15.9 [40.3]	0.4 [1.0]	0.4 [1.0]	25.0 [63.5]	12.3 [31.2]	10.0 [25.4]	160
4782-95	G	3	1	ODP	115/230	1½	1½	2.2 [5.5]	2.1 [5.3]	2.9 [7.3]	4.4 [11.1]	4.7 [11.9]	3.1 [7.8]	6.6 [16.7]	0.5 [1.2]	0.7 [1.7]	19.7 [50.0]	8.0 [20.3]	9.1 [23.1]	91
4786-95		3	3	TEFC	230/460	1½	1½	2.2 [5.5]	2.1 [5.3]	2.9 [7.3]	4.4 [11.1]	4.7 [11.9]	3.1 [7.8]	6.6 [16.7]	0.5 [1.2]	0.7 [1.7]	19.9 [50.5]	8.0 [20.3]	9.1 [23.1]	86

(*) Standard NPT (Female) pipe thread.

(**) This dimension may vary due to motor manufacturer's specifications.

(+) 3-Phase models can also operate on 50 Hz (This will change full load amps and service factor, RPM and priming capabilities).

NOTE: Dimensions are in inches (centimeters) and have a tolerance of ± 1/4".

NOTE: Electric supply for ALL motors must be within ±10% of nameplate voltage rating (e.g. 230V ±10%= 207 to 253).

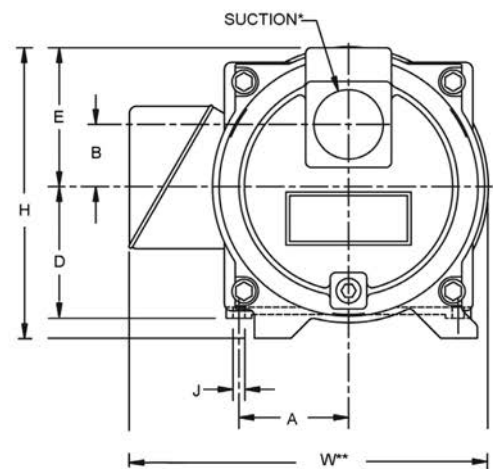
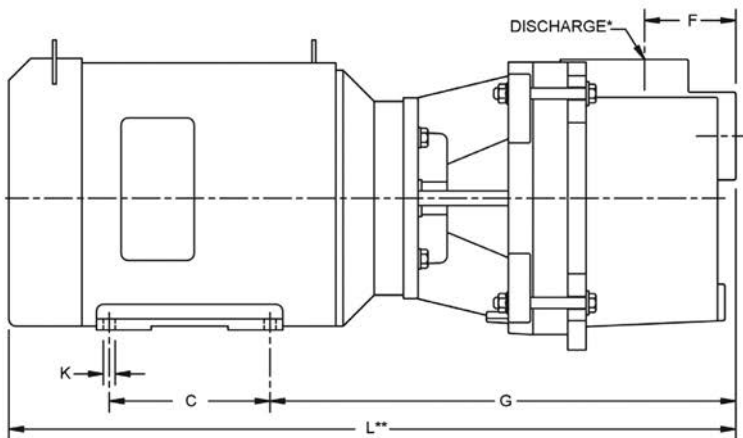

Standard Features

- Cast Iron Construction with 300 Series Investment Cast Stainless Steel Impeller
- Buna-N Mechanical Seal and O-ring
- ODP & TEFC Motors Available on 1-1/2" NPT Single-stage Models
- Removable/Replaceable Volute/Diffuser
- Maximum Solids:
 - 365X Series—5/16"
 - 379X Series—1/16"
 - 478X Series—1/16"
- Single Stage Models Feature Removable Dual Volute Design
- Self-priming to 20 Feet
- Maximum Working Pressure to 150 PSI
- Maximum Temperature 180° F
- Optional Mounting Base for Pumps with JM Motors (**Model 365x Series**)
- QSP - Quick Ship Pump for Many Models