

## 2" Self-Priming Centrifugal Pumps

- **300 Series Investment Cast Stainless Steel Construction with Viton® Seals**
- **Cast Iron Construction with Buna-N Seals**
- **Optional Silicon Carbide Seals Available**
- **2" NPT Port Size**
- **Maximum Temperature**
  - ♦ **Stainless Steel 200° F**
  - ♦ **Cast Iron 180° F**
- **Maximum Flow 150 GPM**
- **Maximum Head 102 Ft. (44 PSI)**
- **Self-Priming up to 20 Feet with Built-in Check Valve**
- **Self-Cleaning, Clog Resistant Impeller**
- **1-1/2 to 3 HP Single or Three Phase 3450 RPM Motors**

Model  
276D-95

This line of AMT Self-Priming Centrifugal pumps is designed for industrial and commercial applications requiring high volume liquid transfer, waste water drainage and processing. These pumps feature a self-cleaning clog resistant impeller capable of handling up to 3/8" diameter semi-solids. Built-in flapper/check valve enables consistent self-priming to 20 feet. Dual volute design reduces radial load on motor. Stainless steel models are especially effective in applications where rust and/or corrosion can develop in systems and also are highly resistant to erosion and chemicals.

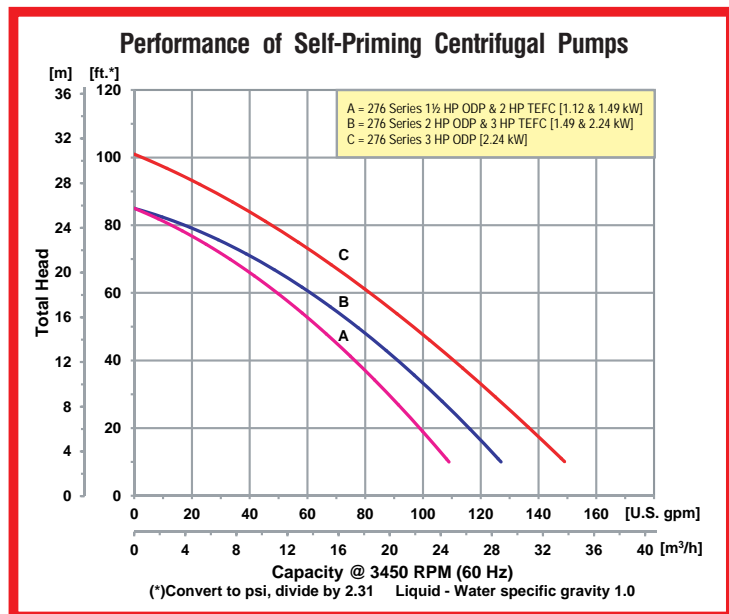

A Gorman-Rupp Company

400 Spring Street • Royersford, PA 19468 USA

[www.amtpump.com](http://www.amtpump.com) • 888-amt-pump (268-7867)

For use with nonflammable liquids compatible with pump component materials. Viton® and Teflon® are registered trademarks of E. I. DuPont.

Tel: 866-777-6060  
Fax: 866-777-6383

Springer Pumps, LLC

Website: [www.springerpumps.com](http://www.springerpumps.com)  
Int'l: +001 267 404 2910

## Pump Dimensional & Specification Data

Model ‡	Curve	HP	PH	ENC	Voltage @ 60 Hz +	Full Load Amps	SUC*	DIS*	L**	W**	H	‡ Ship Wt. (Lbs.)
2762	A	1½	1	ODP	115/230	17/9	2	2	19.3 [49.0]	7.5 [19.0]	11.1 [28.1]	73
2764		1½	3	ODP	230/460	7/4	2	2	18.8 [47.7]	7.5 [19.0]	11.1 [28.1]	70
276B		2	1	TEFC	115/230	22/11	2	2	20.3 [51.5]	9.1 [23.1]	11.1 [28.1]	81
276D		2	3	TEFC	230/460	6/3	2	2	19.8 [50.3]	9.1 [23.1]	11.1 [28.1]	74
2761	B	2	1	ODP	115/230	28/14	2	2	19.3 [49.0]	7.5 [19.0]	11.1 [28.1]	81
2763		2	3	ODP	230/460	7/4	2	2	19.3 [49.0]	7.5 [19.0]	11.1 [28.1]	77
276A		3	1	TEFC	230	16	2	2	20.8 [52.8]	9.1 [23.1]	11.1 [28.1]	90
276C		3	3	TEFC	230/460	8/4	2	2	20.3 [51.5]	9.1 [23.1]	11.1 [28.1]	78
2767	C	3	1	ODP	230	18	2	2	20.5 [52.1]	7.5 [19.0]	11.1 [28.1]	87
2766		3	3	ODP	230/460	9/5	2	2	20.3 [51.5]	7.5 [19.0]	11.1 [28.1]	87

(\*) Standard NPT (Female) pipe thread.

(\*\*) This dimension may vary due to motor manufacturer's specifications.

(+) 3-Phase models can also operate on 50 Hz (This will change full load amps and service factor, RPM and priming capabilities).

NOTE: Dimensions are in inches (centimeters) and have a tolerance of  $\pm 1/4"$ .

NOTE: Electric supply for ALL motors must be within  $\pm 10\%$  of nameplate voltage rating (e.g. 230V  $\pm 10\%$  = 207 to 253).

‡ Add Suffix -95 or -98 for Specific Model (Ex. 2761-95)  
 (-95) Cast Iron Construction with Buna-N Seals  
 (-98) Cast Stainless Steel Construction with Viton® Seal

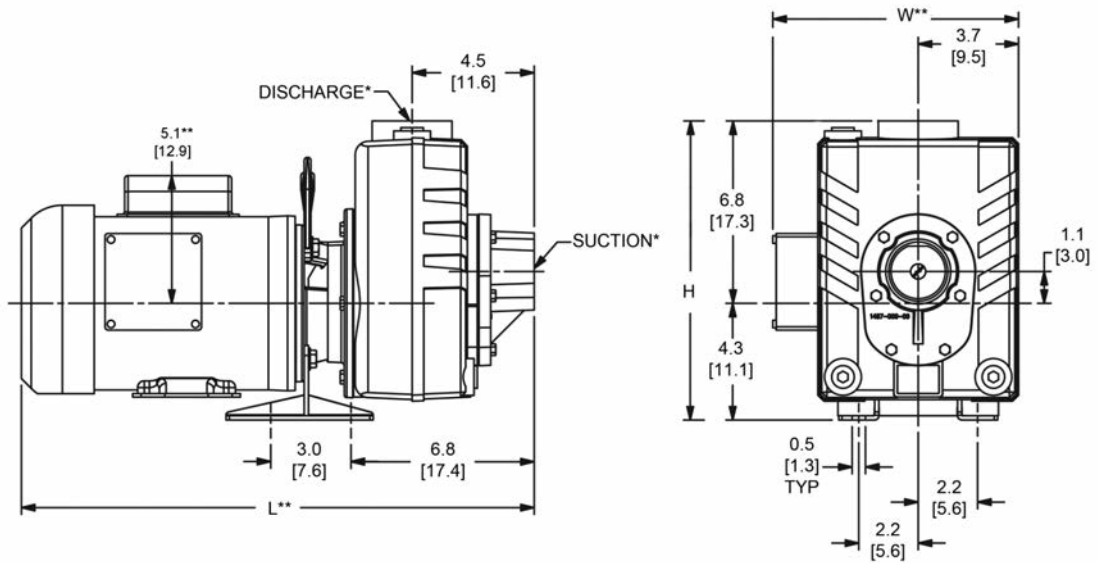

## Standard Features

- 300 Series Investment Cast Stainless Steel Construction with Viton® Seals
- Cast Iron Construction with Buna-N Seals
- Handles 3/8" Diameter Semi-solids
- NEMA 56J Motors with Stainless Steel Shaft
- Maximum Working Pressure 75 PSI
- Available in ODP or TEFC, Single or Three Phase Motors
- Self-priming to 20 Ft.
- Self-cleaning, Clog Resistant Impeller
- Steel Base and Handle Included
- Dual Volute Design
- QSP - Quick Ship Pump for Many Models

**Hazardous Duty/Explosion Proof motors available from stock ranging from 1 to 10 HP; CALL FOR QUOTATION & LEAD TIME!**