

Please read and save this Repair Parts Manual. Read this manual and the General Operating Instructions carefully before attempting to assemble, install, operate or maintain the product described. Protect yourself and others by observing all safety information. The Safety Instructions are contained in the General Operating Instructions. Failure to comply with the safety instructions accompanying this product could result in personal injury and/or property damage! Retain instructions for future reference. AMT reserves the right to discontinue any model or change specifications at any time without incurring any obligation.

©2016 AMT Pump Company, A Subsidiary of The Gorman-Rupp Company, All Rights Reserved.

Wheel Kit

For use with C400-90 & C401-90 square tube frames



DESCRIPTION

This wheel kit is used to make transporting of frame mounted pumps more convenient.

Unpacking

When unpacking the wheel kit, inspect carefully for damage that may have occurred during shipment.

Assembly

Tools required: 3/8", 7/16", 1/2", & (2) 15/16" box, open end, or socket wrenches, C-clamp. Refer to Repair Parts Illustration (Figure 1) for part identification and assembly reference.

AXLE BRACKET ASSEMBLY

1. Elevate frame mounted pump to allow clearance for wheel assembly.
2. Remove rubber feet from frame rails if so equipped.
3. Position Axle bracket left hand (Ref. No. 11) under frame rail towards pump end. Align hole in axle bracket closest to axle hole with rubber foot mount hole in frame rail.
4. Install one 5/16-18x1-1/2 hex bolt (Ref. No. 9) through hole, secure with a 5/16- 18 hex nut (Ref. No. 9).
5. Repeat assembly procedure, install Axle bracket right hand on opposite side frame rail.
6. Insert a 5/8-11x4 hex bolt (Ref. No. 12) thru hub of 10" Wheel (Ref. No. 13)

NOTE: Orient wheel correctly, one side of wheel hub extends past the "tire" face, this side of hub must be positioned in towards axle bracket. Head of bolt must be on the opposite short side of wheel hub.

7. Install a 5/8-11 hex jam nut (Ref. No. 14) on exposed thread of hex bolt. Tighten jam nut finger tight against wheel bearing.
8. Insert exposed threaded portion of bolt through hole in previously installed axle bracket.
9. Install a 5/8-11 hex jam nut (Ref. No. 14) onto bolt. Finger tighten nut against axle bracket.

10. Hold 5/8-11 bolt head with wrench. Lock jam nut into position against axle bracket with second wrench. Check to make sure wheel still rotates freely.
11. Repeat assembly procedure, assemble second wheel to opposite side axle bracket.

INSTALL SUPPORT LEG

1. Install one Rubber feet (Ref. No. 7) and rising block (Ref. No. 5) on a 5/16-18x2-3/4" bolt (Ref. No. 8).
2. Insert bolt through hole in frame rail from the bottom up.
3. Fasten bolt in position with a 5/16-18 hex flange nut (Ref. No. 6).
4. Repeat assembly procedure, assemble second support leg to opposite frame rail.

HANDLE ASSEMBLY

1. Locate Handle (Ref. No. 1) against top of frame rail (opposite end from wheel). End of handle should extend approximately 11"-12" from vertical frame end.
2. Hold handle in place with a C-clamp, or other clamping device.
3. Assemble two Handle Clamps (Ref. No. 2) around handle and roll frame. Fasten with four 1/4-20x1-1/2 hex bolts (Ref. No. 3) and four 1/4-20 hex flange nuts (Ref. No. 4)
4. Position handle clamps approximately 1/2"-1" from end of handle close to bend.
5. Securely tighten bolts. Over tightening bolts will bend clamp ears.
6. Repeat assembly procedure, assemble second handle to opposite side frame rail end.

For Repair Parts contact dealer where pump was purchased.

Please provide following information:

- Model Number
- Serial Number (if any)
- Part/Kit Description and Number

NOTE: Parts are available only in kits listed, parts are not available individually.

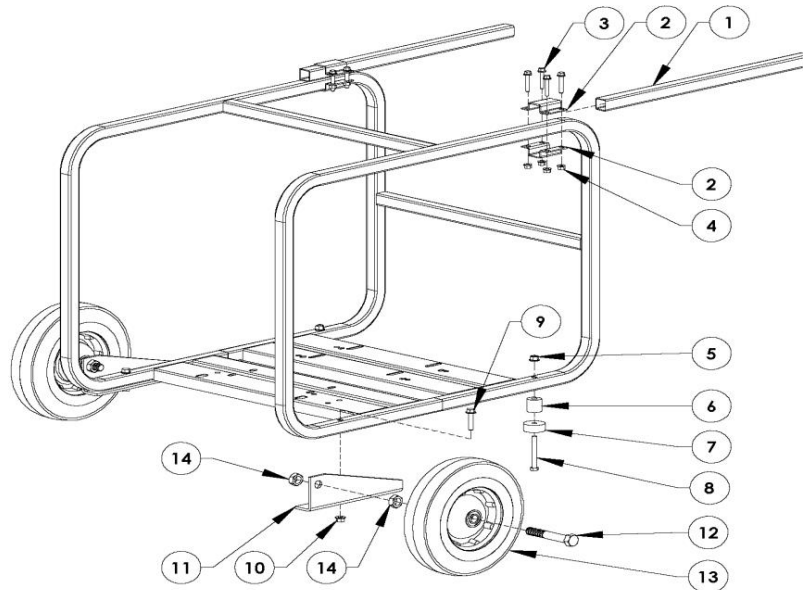

Figure 1 – Repair Parts Illustration

Repair Parts List

| Ref. No. | Description | Part Number | Qty. |
|----------|--------------------------|------------------|------|
| 1 | Handle | C402-102-00 | 2 |
| K2 | Clamp Kit | C400-102-90 | 1 |
| 2 | Clamp Bracket | incl. w/Ref K2 | 4 |
| 3 | 1/4-20 x 1-1/2 Hex Bolt | incl. w/Ref K2 * | 8 |
| 4 | 1/4-20 Hex Flange Nut | incl. w/Ref K2 * | 8 |
| K5 | Support Foot Kit | C402-100-90 | 1 |
| 5 | Rising Block | incl. w/Ref K5 | 2 |
| 6 | 5/16-18 Hex Flange Nut | incl. w/Ref K5 * | 2 |
| 7 | Rubber Foot | incl. w/Ref K5 | 2 |
| 8 | 5/16-18 x 3-1/2 Hex Bolt | incl. w/Ref K5 * | 2 |
| K9 | Axle Bracket Kit | C402-101-90 | 1 |
| 9 | 5/16-18 x 1-1/2 Hex Bolt | incl. w/Ref K8 * | 2 |
| 10 | 5/16-18 Hex Flange Nut | incl. w/Ref K8 * | 2 |
| 11 | Axle Bracket Right | incl. w/Ref K8 | 1 |
| | Axle Bracket Left | incl. w/Ref K8 | 1 |
| 12 | 5/8-11 x 4 Hex Bolt | incl. w/Ref K8 * | 2 |
| 13 | 10" Diameter Wheel | 1663-000-00 | 2 |
| 14 | 5/8-11 Hex Jam Nut | incl. w/Ref K8 * | 4 |

(*) Standard Hardware Item, Available Locally





AMT Pump Company
(herein "AMT")
400 Spring Street
Royersford, PA 19468
Phone: (610) 948-3800
Fax: (610) 948-5300
www.amtpump.com

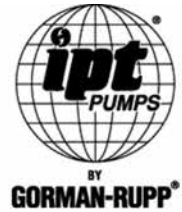

General Information

SALES POLICY: AMT products are sold through our established Distributors. We do not sell direct to the consumer or organization not entitled to trade recognition. Therefore, possession of our catalogs and/or price list(s) does not infer an offer to sell.

MINIMUM ORDER: We appreciate your order, however, all orders are subject to a minimum \$35.00 net invoice charge (excluding freight). This applies to all pump and parts purchase orders.

PRICES: Prices are subject to change without notice. All orders accepted are subject to prices in effect at time of shipment.

PAYMENT TERMS: Terms, upon establishment of credit, are Net 30 days. Past due accounts may be subject to a service charge of 1.5% per month. Domestic or assignable letter of credit is required for all export trade.

PAST DUE ACCOUNTS: AMT reserves the right to withhold open account shipments on any past due account. Invoices are considered past due after thirty (30) days. In the interest of sound business, all orders are subject to approval of the Credit Department.

SHIPPING INSTRUCTIONS: All shipments will be made F.O.B. the factory. Where instructions for shipment do not appear on the order, the shipment will be made according to our best judgment. Full risk of loss (including transportation delays and losses) shall pass to the customer upon delivery of the products to the carrier at the F.O.B. point. When loss or delay occurs, primary responsibility for tracing rests with the customer. When there is LOSS or APPARENT VISIBLE DAMAGE to a shipment, when tendered for delivery, **DO NOT** give the carrier a clear receipt. Note such damage on the carrier's delivery receipt and **HAVE THE DRIVER SIGN THE RECEIPT.**

PRODUCT REVISIONS: AMT reserves the right to discontinue, change or improve its products or any portions thereof without being obligated to provide such a change or improvement for units sold and/or shipped prior to such a change or improvement.

LEAD TIME: Products designated "Quick Ship Product", also referred to as "QSP" will normally be shipped within 24 hours of receipt of a non-cancellable purchase order. Only limited quantities of "QSP" pumps are available.

STANDARD LEAD TIME: Lead time is two weeks for all non "QSP" product. AMT reserves the right to revise lead times as required due to availability of materials and all other causes beyond our control.

VIP SHIPMENT: Select AMT and IPT branded pumps are available for next day shipment for non-QSP (Quick Ship Products) items and subjected to a specific model surcharge per unit noted in the respective price book. Requires calling for availability, confirmation and a non-cancellable purchase order or credit card payment prior to shipment. The expedited shipping charges are an additional cost added separately from the VIP charges per item. AMT reserves the right to revise lead times as required due to availability of materials and all other causes beyond our control. QSP quantities are limited as determined by AMT.

ALL purchase orders must be submitted via hard copy sent to AMT customer service department by fax, EDI or e-mail.

RETURN GOODS POLICY: Goods shall not be returned without a return goods authorization number (RGA) issued by AMT customer service. The RGA number must be listed on the packing list. Only current model and part numbers with a valid date code may be returned (within one year from date of purchase). **A 20% restocking and packaging charge will apply to all returns. All shipping charges must be pre-paid. No exceptions.**

ORDER CHANGES BY CUSTOMER: Orders in process may not be changed except with written consent and may be subject to special charges.

12 Month Limited Warranty

EXTENT AND DURATION OF LIMITED WARRANTY

Coverage: AMT Pump Company (herein "AMT") or IPT Pumps by Gorman-Rupp (herein "IPT") or Gorman-Rupp Industries Division of the The Gorman-Rupp Company, Patterson, or the Gorman-Rupp Company (herein referred to as "G-R Unit") each individually warrants that its products and parts shall be free from defects in material and workmanship for twelve (12) months from the date of purchase by the original end user when installation is made and maintenance is performed in accordance with G-R Unit's recommendations. Wear and tear resulting from use and items normally consumed in use are not covered.

EXCEPTIONS

(A) This Limited Warranty shall not apply to mechanical seals in AMT or IPT pumps and the following products and parts: engines, motors, trade accessories and all other products, components, parts and materials not manufactured by the G-R Units. These items may, however, be covered by the warranties of their respective manufacturers. (B) This warranty does not extend to or apply to any unit which has been repaired or altered at any place other than by a G-R Unit, or by persons not expressly approved by a G-R Unit to make repairs or alterations, nor to any unit the serial number, model number or identification of which has been removed, defaced or altered. (C) This warranty does not extend to any product manufactured by a G-R Unit, which has been subjected to mis-use, neglect, accident, improper installation, or use in violation of instructions furnished by a G-R Unit. (D) Pump Kits: This warranty does not extend to any product sold by a G-R Unit unassembled as a Pump Kit. Pump Kits are warranted against defects in material and workmanship for 60 days from the date of shipment from a G-R Unit. Any Pump Kit parts deemed defective by a G-R Unit will be replaced free of charge within 60 days of shipment. Pump Kits are not returnable for credit.

LIMITATIONS

THE G-R UNITS' SOLE AND EXCLUSIVE WARRANTY WITH RESPECT TO THEIR PRODUCTS AND PARTS IS THIS LIMITED WARRANTY. THIS LIMITED WARRANTY IS IN LIEU OF ALL OTHER EXPRESS AND/OR IMPLIED WARRANTIES, INCLUDING IMPLIED WARRANTIES OF MERCHANTABILITY AND FITNESS FOR PARTICULAR PURPOSE.

EXCLUSIVE REMEDY AND DAMAGES

The sole and exclusive remedy for breach of this Warranty by a G-R Unit and the entire extent of its liability for such breach or for damages arising from the use of the products and parts covered under this Limited Warranty, shall be as follows:

- Repair or Replacement:** If inspection shows that any G-R Unit product or part covered under this Limited Warranty is defective in materials or workmanship, the G-R Unit shall repair or replace the defective or non-conforming product or part without charge, whichever the G-R Unit chooses. You must have properly maintained and used the product or part claimed to be defective in accordance with the maintenance schedule or manual, which comes with the product. No allowance will be made for labor, installation, removal, transportation or other charges incurred by you in connection with such repair or replacement.
- To obtain the above remedy:

- Immediately notify the G-R Unit upon discovery of the claimed defect in materials or workmanship and provide the serial number or date code of the product and/or part(s) or provide the G-R Unit with the invoice or bill of sale referencing the product by no later than the expiration date of the warranty period.
- The G-R Unit will advise whether inspection will be necessary and how whether repair or replacement will be made. If inspection by the G-R Unit is necessary, the pump or defective part must be sent freight pre-paid to the G-R Unit. Return shipment will be F.O.B. the G-R Unit's plant.
- Return Goods Authorization Requirement:** No product will be accepted for return or replacement without the prior written authorization of the G-R Unit. Upon such authorization, and in accordance with instructions from the G-R Unit, the product will be returned to the G-R Unit, shipping charges prepaid by the Buyer.

- Damages:** The G-R Unit's liability for damages for breach of this Limited Warranty shall not exceed the amount of the purchase price of the product or part(s) in respect to which Such damages are claimed. **IN NO EVENT SHALL THE G-R UNITS BE LIABLE FOR INCIDENTAL, CONSEQUENTIAL OR SPECIAL DAMAGES FOR BREACH OF THIS LIMITED WARRANTY.**

Some states do not allow the exclusion or limitation of incidental or consequential damages, so the above limitation or exclusion may not apply to you. This Limited Warranty gives you specific legal rights, and you may also have other rights, which vary from state to state.



A Gorman-Rupp Company

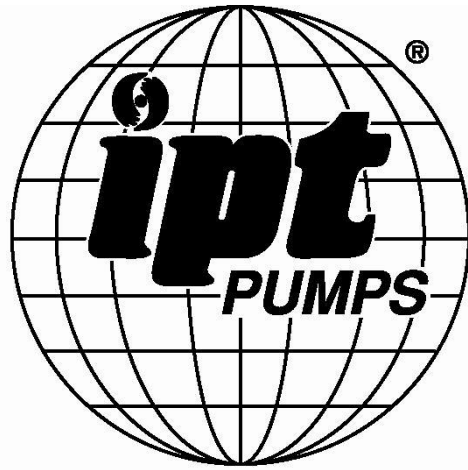

BY
GORMAN-RUPP®

www.amtpump.com

