

Please read and save this Repair Parts Manual. Read this manual and the General Operating Instructions carefully before attempting to assemble, install, operate or maintain the product described. Protect yourself and others by observing all safety information. The Safety Instructions are contained in the General Operating Instructions. Failure to comply with the safety instructions accompanying this product could result in personal injury and/or property damage! Retain instructions for future reference. AMT reserves the right to discontinue any model or change specifications at any time without incurring any obligation.

©2018 AMT Pump Company, A Subsidiary of The Gorman-Rupp Company, All Rights Reserved.

Periodic maintenance and inspection is required on all pumps to ensure proper operation. Unit must be clear of debris and sediment. Inspect for leaks and loose bolts. Failure to do so voids warranty.

Submersible Pump 12VDC Series



Refer to pump manual 1808-634-00 for General Operating and Safety Instructions.

DESCRIPTION

The AMT Submersible 12VDC pump is designed for use in remote locations without electricity and for emergency back-up during power failure. Unit comes assembled and requires minimum 55 amp-hour battery for proper operation. For use with non-flammable liquids compatible with pump components.

⚠ IMPORTANT

Read all safety warnings and instructions in this manual completely before installation and start-up of the pump. It is the responsibility of the purchaser to retain this manual for reference. Failure to comply with the recommendations stated in this manual will damage the pump and void factory warranty.

1. Make sure the vehicle and the pump are not in contact during connection.
2. Do not use power cable for handling unit.
3. Do not run pump completely dry for extended periods. Damage to shaft seal may result

⚠ WARNING

DANGER: Not for use with fluids that have a flash point below 100° F (38° C) (Example: gasoline, alcohol). Sparking could result in death.

OPERATING AND INSTALLATION INSTRUCTIONS

Hose: Since the pump develops relatively low pressure, it is recommended that non-collapsible hose be used for maximum pumping rates.

Hoisting and Lowering: Attach a line to the metal handle on the top of the pump for hoisting or lowering the unit. **Do not use power cable for handling unit.**

To Operate: Lower unit into liquid to be pumped and activate switch. Do not run dry; damage to shaft seal will result.

RUNNING TIME: This unit draws about 30 amperes and can be operated about 1 hour on a fully charged 55 amp-hour battery and still permit starting of vehicle under normal conditions. Caution should be used when running time exceeds 30 or 40 minutes without engine running to recharge battery, particularly in cold weather when battery efficiency is lowered. Battery size (amt-hour rating) and the use of other accessories such as lights and radios, etc. must be taken into consideration for practical running periods without engine running.

OVERLOAD PROTECTION is provided by means of a 40 amp automatic reset circuit breaker located under top cover.

TROUBLE SHOOTING

NOTE: (Most common cause of failure to run, is due to hardened mud and sand at impeller.) Remove strainer to check.

⚠ CAUTION

Should unit not operate, always check freeness of rotation of impeller by inserting screwdriver through hole in base plate into slot in end of shaft.

MOTOR WILL NOT RUN:

1. Poor connection at battery.
2. Impeller locked with foreign material.
3. Insufficient impeller clearance.
4. Damaged power cable or loose connection internally in motor assembly.
5. Bad switch or circuit breaker. Connect power leads directly to motor leads to check.
6. Worn motor brushes or out of position to make contact with armature.

PERFORMANCE LOW:

1. Strainer screen partially plugged.
2. Impeller rubbing. Check freeness of rotation with screwdriver inserted through hole in base plate into slotted end of shaft.
3. Battery not fully charged.
4. Discharge restriction such as kinked hose or excessive discharge head.

MOTOR RUNS BACKWARDS:

1. Check wiring for correct polarity.

SERVICE & REPAIR INSTRUCTIONS DISASSEMBLY:

Impeller and shaft seal can be inspected and serviced from lower end of pump by removal of 4 cap screws securing base plate, strainer screen and suction cover. Screwdriver slot is provided in end of motor shaft to turn shaft while holding impeller for removal. This permits removal of impeller without disassembly of upper motor housing to hold motor shaft.

Alternately, there is a shaft extension with two flats on the rear of the motor for use when the impeller is difficult to remove. The upper motor cover must be removed to expose this shaft extension.

To service motor, remove 4 hex nuts and bump top cover free from housing tube. Raise sufficiently to disconnect power cable connections. Slide housing tube up from pump casing and motor will be exposed for service or removal.

⚠ IMPORTANT

Make certain that wire leads are installed per Figure 1. Install top cover as indicated by arrow and instruction on top of cover. Make sure wires do not contact motor shaft when installing motor cover.

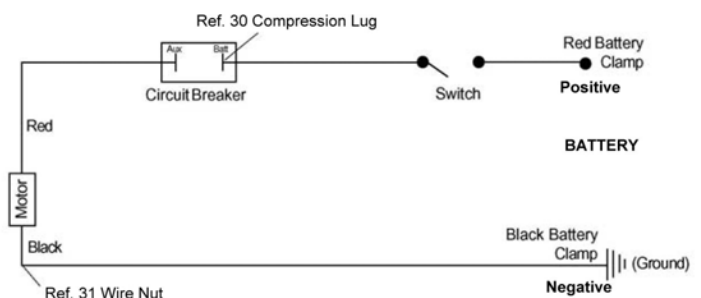

Figure 1 - Wiring Diagram

Submersible Pump 12VDC Series

For Repair Parts contact dealer where pump was purchased.

Please provide following information:

- Model Number
- Serial Number (if any)

Part description and number as shown in parts list

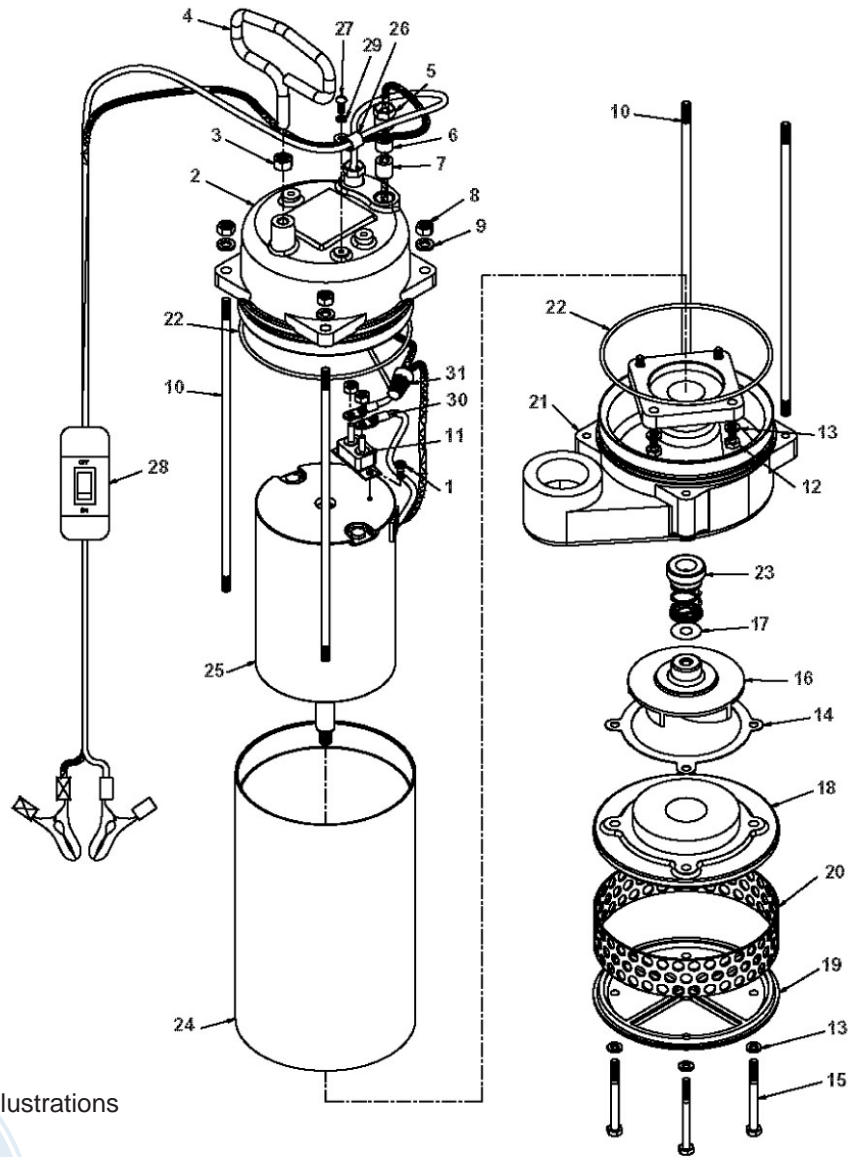
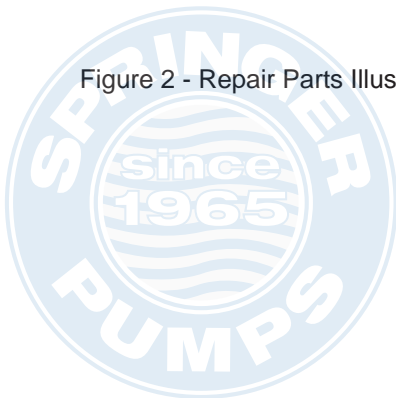
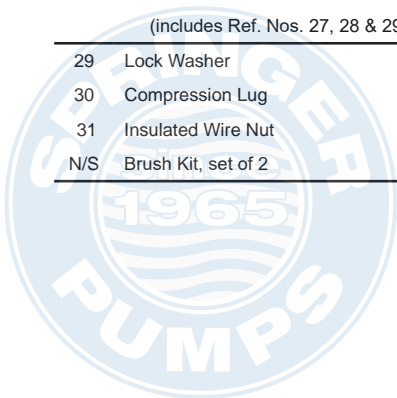

Figure 2 - Repair Parts Illustrations



Repair Parts List

Ref No.	Description	Part Number	QTY
1	Self Tapping Screw	included with Ref 11	2
2	Motor Cover Kit	5890-040-90	1
3	Hex Nut	included with Ref 4	1
4	Handle Kit	5890-100-90	1
5	Gland Nut Kit (includes Ref. Nos. 5,6 & 7)	5890-420-90	2
6	Gland spacer	included with Ref 5	2
7	Sealing Ring	included with Ref 5	2
8	Hex Nut	included with Ref 10	4
9	Lock Washer	included with Ref 10	4
10	Stud Kit (1 each 8, 9 & 10) (includes Ref. Nos. 8, 9 & 10)	5890-140-90	4
11	Circuit Breaker Kit (includes Ref. Nos. 1, 30 & 31)	5890-350-90	1
12	Hex Head Bolt	included with Ref 21	4
13	Lock Washer	included with Ref 20 & 21	8
14	Seal & Gasket Kit (includes Ref. Nos. 22 & 23)	5890-300-90	1
15	Hex Head Bolt	included with Ref 20	4
16	Impeller Kit (includes Ref. Nos. 17)	5890-010-90	1
17	Shims (set of 3)	included with Ref 16	1
18	Suction Cover	included with Ref 20	1
19	Strainer Plate	included with Ref 20	1
20	Strainer & Cover Kit (includes Ref. Nos. 13, 15, 18 & 19)	5890-020-90	1
21	Casing Volute Kit (includes Ref. Nos. 12 & 13)	5890-001-90	1
22	O-ring	included with Ref 14	2
23	Mechanical Seal	included with Ref 14	1
24	Casing Tube	5890-080-90	1
25	Motor Assembly	Replace Pump	1
26	Cable Clamp	No Longer Used	1
27	Screw	included with Ref 28	1
28	Cord & Switch Kit (includes Ref. Nos. 27, 28 & 29)	5890-351-90	1
29	Lock Washer	included with Ref 28	1
30	Compression Lug	included with Ref 11	1
31	Insulated Wire Nut	included with Ref 11	1
N/S	Brush Kit, set of 2	5890-352-90	1





AMT Pump Company
(herein "AMT")
400 Spring Street
Royersford, PA 19468
Phone: (610) 948-3800
Fax: (610) 948-5300
www.amtpump.com

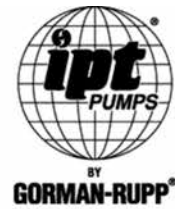

General Information

SALES POLICY: AMT products are sold through our established Distributors. We do not sell direct to the consumer or organization not entitled to trade recognition. Therefore, possession of our catalogs and/or price list(s) does not infer an offer to sell.

MINIMUM ORDER: We appreciate your order, however, all orders are subject to a minimum \$35.00 net invoice charge (excluding freight). This applies to all pump and parts purchase orders.

PRICES: Prices are subject to change without notice. All orders accepted are subject to prices in effect at time of shipment.

PAYMENT TERMS: Terms, upon establishment of credit, are Net 30 days. Past due accounts may be subject to a service charge of 1.5% per month. Domestic or assignable letter of credit is required for all export trade.

PAST DUE ACCOUNTS: AMT reserves the right to withhold open account shipments on any past due account. Invoices are considered past due after thirty (30) days. In the interest of sound business, all orders are subject to approval of the Credit Department.

SHIPPING INSTRUCTIONS: All shipments will be made F.O.B. the factory. Where instructions for shipment do not appear on the order, the shipment will be made according to our best judgment. Full risk of loss (including transportation delays and losses) shall pass to the customer upon delivery of the products to the carrier at the F.O.B. point. When loss or delay occurs, primary responsibility for tracing rests with the customer. When there is LOSS or APPARENT VISIBLE DAMAGE to a shipment, when tendered for delivery, **DO NOT** give the carrier a clear receipt. Note such damage on the carrier's delivery receipt and **HAVE THE DRIVER SIGN THE RECEIPT.**

PRODUCT REVISIONS: AMT reserves the right to discontinue, change or improve its products or any portions thereof without being obligated to provide such a change or improvement for units sold and/or shipped prior to such a change or improvement.

LEAD TIME: Products designated "Quick Ship Product", also referred to as "QSP" will normally be shipped within 24 hours of receipt of a non-cancellable purchase order. Only limited quantities of "QSP" pumps are available.

STANDARD LEAD TIME: Lead time is two weeks for all non "QSP" product. AMT reserves the right to revise lead times as required due to availability of materials and all other causes beyond our control.

VIP SHIPMENT: Select AMT and IPT branded pumps are available for next day shipment for non-QSP (Quick Ship Products) items and subjected to a specific model surcharge per unit noted in the respective price book. Requires calling for availability, confirmation and a non-cancellable purchase order or credit card payment prior to shipment. The expedited shipping charges are an additional cost added separately from the VIP charges per item. AMT reserves the right to revise lead times as required due to availability of materials and all other causes beyond our control. QSP quantities are limited as determined by AMT.

ALL purchase orders must be submitted via hard copy sent to AMT customer service department by fax, EDI or e-mail.

RETURN GOODS POLICY: Goods shall not be returned without a return goods authorization number (RGA) issued by AMT customer service. The RGA number must be listed on the packing list. Only current model and part numbers with a valid date code may be returned (within one year from date of purchase). **A 20% restocking and packaging charge will apply to all returns. All shipping charges must be pre-paid. No exceptions.**

ORDER CHANGES BY CUSTOMER: Orders in process may not be changed except with written consent and may be subject to special charges.

12 Month Limited Warranty

EXTENT AND DURATION OF LIMITED WARRANTY

Coverage: AMT Pump Company (herein "AMT") or IPT Pumps by Gorman-Rupp (herein "IPT") or Gorman-Rupp Industries Division of the The Gorman-Rupp Company, Patterson, or the Gorman-Rupp Company (herein referred to as "G-R Unit") each individually warrants that its products and parts shall be free from defects in material and workmanship for twelve (12) months from the date of purchase by the original end user when installation is made and maintenance is performed in accordance with G-R Unit's recommendations. Wear and tear resulting from use and items normally consumed in use are not covered.

EXCEPTIONS

(A) This Limited Warranty shall not apply to mechanical seals in AMT or IPT pumps and the following products and parts: engines, motors, trade accessories and all other products, components, parts and materials not manufactured by the G-R Units. These items may, however, be covered by the warranties of their respective manufacturers. (B) This warranty does not extend to or apply to any unit which has been repaired or altered at any place other than by a G-R Unit, or by persons not expressly approved by a G-R Unit to make repairs or alterations, nor to any unit the serial number, model number or identification of which has been removed, defaced or altered. (C) This warranty does not extend to any product manufactured by a G-R Unit, which has been subjected to mis-use, neglect, accident, improper installation, or use in violation of instructions furnished by a G-R Unit. (D) Pump Kits: This warranty does not extend to any product sold by a G-R Unit unassembled as a Pump Kit. Pump Kits are warranted against defects in material and workmanship for 60 days from the date of shipment from a G-R Unit. Any Pump Kit parts deemed defective by a G-R Unit will be replaced free of charge within 60 days of shipment. Pump Kits are not returnable for credit.

LIMITATIONS

THE G-R UNITS' SOLE AND EXCLUSIVE WARRANTY WITH RESPECT TO THEIR PRODUCTS AND PARTS IS THIS LIMITED WARRANTY. THIS LIMITED WARRANTY IS IN LIEU OF ALL OTHER EXPRESS AND/OR IMPLIED WARRANTIES, INCLUDING IMPLIED WARRANTIES OF MERCHANTABILITY AND FITNESS FOR PARTICULAR PURPOSE.

EXCLUSIVE REMEDY AND DAMAGES

The sole and exclusive remedy for breach of this Warranty by a G-R Unit and the entire extent of its liability for such breach or for damages arising from the use of the products and parts covered under this Limited Warranty, shall be as follows:

- Repair or Replacement:** If inspection shows that any G-R Unit product or part covered under this Limited Warranty is defective in materials or workmanship, the G-R Unit shall repair or replace the defective or non-conforming product or part without charge, whichever the G-R Unit chooses. You must have properly maintained and used the product or part claimed to be defective in accordance with the maintenance schedule or manual, which comes with the product. No allowance will be made for labor, installation, removal, transportation or other charges incurred by you in connection with such repair or replacement.
 - Immediately notify the G-R Unit upon discovery of the claimed defect in materials or workmanship and provide the serial number or date code of the product and/or part(s) or provide the G-R Unit with the invoice or bill of sale referencing the product by no later than the expiration date of the warranty period.
 - The G-R Unit will advise whether inspection will be necessary and how whether repair or replacement will be made. If inspection by the G-R Unit is necessary, the pump or defective part must be sent freight pre-paid to the G-R Unit. Return shipment will be F.O.B. the G-R Unit's plant.
 - Return Goods Authorization Requirement:** No product will be accepted for return or replacement without the prior written authorization of the G-R Unit. Upon such authorization, and in accordance with instructions from the G-R Unit, the product will be returned to the G-R Unit, shipping charges prepaid by the Buyer.
- Damages:** The G-R Unit's liability for damages for breach of this Limited Warranty shall not exceed the amount of the purchase price of the product or part(s) in respect to which Such damages are claimed. **IN NO EVENT SHALL THE G-R UNITS BE LIABLE FOR INCIDENTAL, CONSEQUENTIAL OR SPECIAL DAMAGES FOR BREACH OF THIS LIMITED WARRANTY.**

Some states do not allow the exclusion or limitation of incidental or consequential damages, so the above limitation or exclusion may not apply to you. This Limited Warranty gives you specific legal rights, and you may also have other rights, which vary from state to state.