

Please read and save this Repair Parts Manual. Read this manual and the General Operating Instructions carefully before attempting to assemble, install, operate or maintain the product described. Protect yourself and others by observing all safety information. The Safety Instructions are contained in the General Operating Instructions. Failure to comply with the safety instructions accompanying this product could result in personal injury and/or property damage! Retain instructions for future reference.

Submersible Pumps

Drainage / Sump Series

Refer to form 1808-636-00 for General Operating and Safety Instructions.

Description

These general purpose centrifugal Submersible Drainage / Sump Pumps are intended for use in residential, commercial, and industrial settings. Examples include: Basements, boats, tanks, and other general drainage applications involving clean liquids. Submersible design means low noise and no priming issues.

Each unit is completely assembled and features a self-cleaning semi-open impeller and automatic on/off float switch (stainless steel unit has no switch). All pumps incorporate a mechanical shaft seal with carbon and ceramic wear faces. Cast iron and SS pumps also feature a secondary shaft seal and oil chamber.

Pumps have a 3450 RPM electric motor fitted with a finished 3-prong grounding type power cord. Motors are rated continuous duty and have automatic restart thermal overload protection. Handle liquids from 40° to 104° F (4° to 40° C). For use with clean, clear water and other non-flammable, non-abrasive liquids compatible with pump component materials.

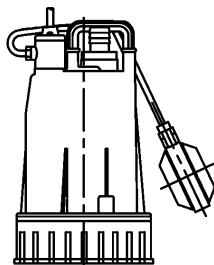

Specifications

Model	Discharge Outlet	HP	Power Supply @60 Hz	Max. Amps	Cord Length	Basic Const.	Impeller Material	Seals	Weight (lbs.)
5800-99	1" HB	1/8	115VAC, 1 Phase	1.5	13'	Plastic*	Plastic	Buna N	11
5810-99	1 1/4" HB	1/3	115VAC, 1 Phase	3.0	13	Plastic*	Plastic	Buna N	13
5811-99	1 1/2" HB	1/2	115VAC, 1 Phase	4.9	13	Plastic*	Plastic	Buna N	15
5790-95	1 1/2" NPT	1/3	115VAC, 1 Phase	4.2	20	Cast Iron**	Cast Iron	Buna N	35
5792-95	2 NPT	1/2	115VAC, 1 Phase	6.9	20	Cast Iron**	Cast Iron	Buna N	42
5780-98	2 NPT	1/2	115VAC, 1 Phase	5.0	20	SS***	SS	Viton	26

NOTE: Driver data is subject to change without notice, see label on driver for actual specifications.

(HB) Male Hose Barb; (NPT) Standard NPT (female) pipe thread; (SS) 304 Stainless Steel

(*) With stainless steel, brass, and plastic components.

(**) With stainless steel, brass, plastic, and plated steel components.

(***) With stainless steel and plastic components.

Performance

Model	GPM of Water at Total Head in Feet						Max. Head†
	5'	10'	15'	20'	25'	30'	
5800-99	15	7	—	—	—	—	14 ft.
5810-99	25	13	—	—	—	—	14
5811-99	41	30	18	3	—	—	21
5790-95	52	46	40	31	18	—	30
5792-95	62	57	50	42	34	22	37
5780-98	56	50	43	34	21	6	32

(†) Shutoff; to convert to psi, divide by 2.31

Figure 1 - Dimensions

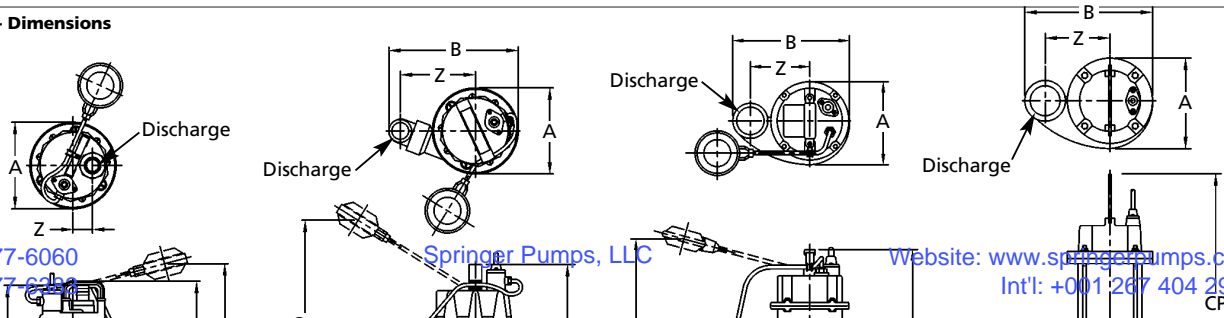

Models 5780-98, 5790-95, 5792-95, 5800-99, 5810-99 and 5811-99

Maintenance

⚠ WARNING *Make certain that unit is disconnected from power source before attempting to service or remove any component.*

POWER CORD REPLACEMENT

Periodically inspect power cord and replace whenever abrasion, cracking, softening, or other signs of deterioration are found.

Refer to Figures 2 and 3.

1. Place unit on workbench in upright position. Clean dirt and rust from around wire cover (Ref. No. 10).
2. Remove two fasteners (Ref. No. 2) which hold cord retainer (Ref. No. 3).
3. Remove fastener (Ref. No. 9) that attaches float switch (Ref. No 5).
4. Remove fastener(s) (Ref. No. 4) at handle (Ref. No. 7) to free wire loom (Ref. No. 6).
5. Remove four fasteners (Ref. No. 8) which hold wire cover in place.
6. Carefully pry cover from unit with screwdriver.

IMPORTANT: Be careful to keep rust and other debris from falling into motor housing during cover removal.

7. Take note of proper wire configuration, and connect new power

cord/float (Ref. No. 1) in identical fashion.

⚠ WARNING *If unsure about above information or wiring diagrams, consult an electrician familiar with motor wiring.*

8. Clean sealing flanges if necessary and reassemble pump in reverse order.

IMPELLER INSPECTION / REPLACEMENT (MODELS 5790-95, 5792-95 AND 5780-98 ONLY)

If pump develops poor performance characteristics, impeller may be worn or clogged.

IMPELLER INSPECTION

Refer to Figure 3.

1. Place unit on workbench in horizontal position and clean rust and buildup from around pump-to-motor flange.
2. Remove three fasteners (Ref. No. 29) to free screen (Ref. No. 28).
3. Remove three fasteners (Ref. No. 30) and use screwdriver to pry base (Ref. No. 27) from pump assembly.
4. Inspect impeller (Ref. No. 24). If clog is found, remove debris and reassemble in reverse order. If damage to impeller is found, such as pitting, deep grooves, or breakage, proceed to

next section.

IMPELLER REPLACEMENT

5. Remove impeller fastener (Ref. No. 26) by unscrewing in counterclockwise direction.

NOTE: To prevent motor shaft from turning, wedge a screwdriver between

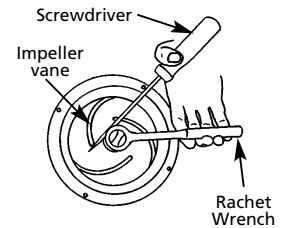

Figure 2 - Impeller Removal

impeller vane and impeller fastener (see Figure 2).

6. Slide off impeller washer (Ref. No. 25). Impeller is keyed to motor shaft/rotor (Ref. No. 13) and can now be pulled free.
7. Install replacement impeller and reassemble in reverse order.

MECHANICAL SEAL REPLACEMENT (MODELS 5790-95, 5792-95 AND 5780-98 ONLY)

Motor internals are protected from contact with liquid being pumped by a mechanical shaft seal and oil cavity. When seal wears out, potential motor life will be com-

For Repair Parts, contact dealer where pump was purchased

Please provide the following information:

- Model number
- Serial number (if any)
- Part description and number as shown in parts list

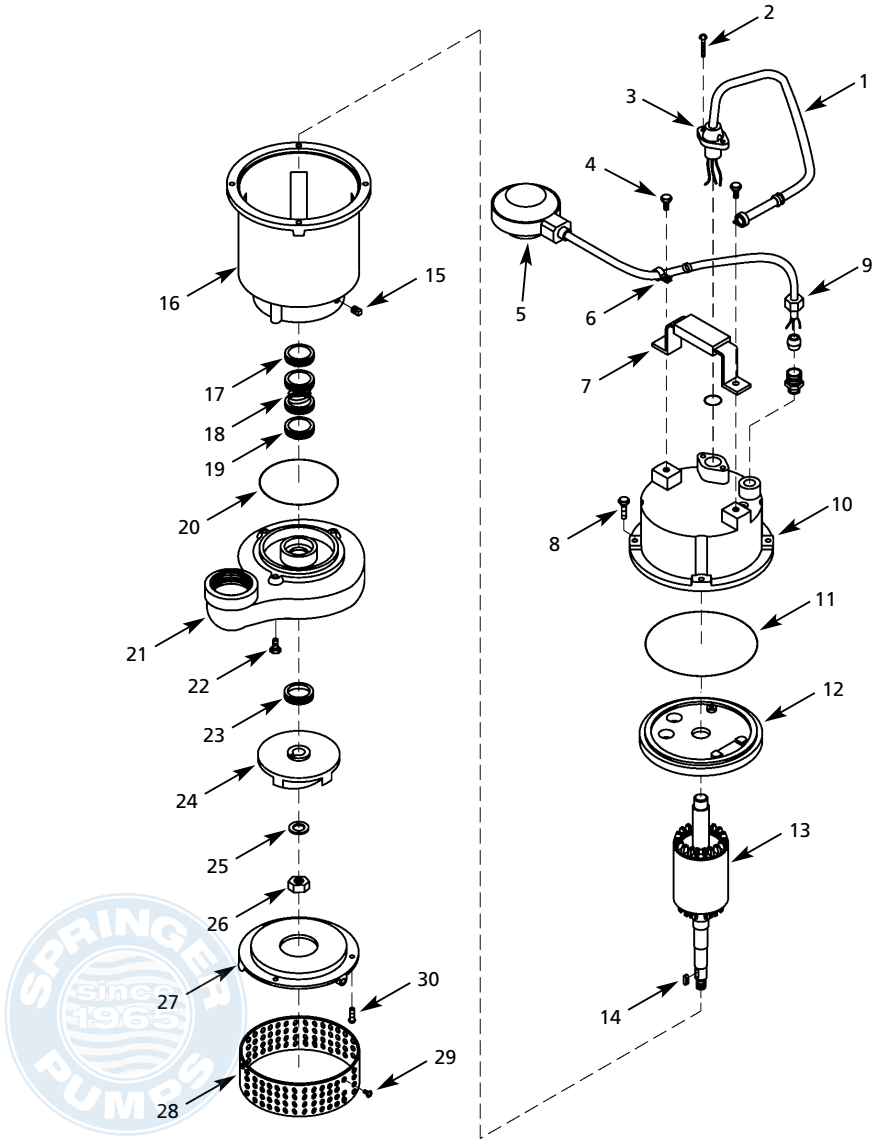

Figure 3 - Repair Parts Illustration

Repair Parts List

Ref. No.	Description	Part Number For Models:			Qty.
		1-Inch - 1/8HP 5800-99	1 1/2-Inch - 1/3HP 5810-99	1 1/2-Inch - 1/2HP 5811-99	
1	~ Power cord/float kit	5800-350-90	5810-350-90	5811-350-90	1

NOTE: Power cord/float kit is the only repair part available for models 5800-99, 5810-99, and 5811-99.

Repair Parts List

Ref. No.	Description	Part Number For Models:			Qty.
		1 1/2-Inch - 1/3HP 5790-95	2-Inch - 1/2HP 5792-95	2-Inch - 1/2HP 5780-98	
1	~ Power cord/float kit	5790-350-90	5792-350-90	5780-350-90	1
2	Fastener	(see Ref. No. 1)	(see Ref. No. 1)	(see Ref. No. 1)	2
3	Retainer	(see Ref. No. 1)	(see Ref. No. 1)	(see Ref. No. 1)	1
4	Fastener	*	*	*	2
5	Float switch	(see Ref. No. 1)	(see Ref. No. 1)	(see Ref. No. 1)	1
6	Wire loom	(see Ref. No. 1)	(see Ref. No. 1)	(see Ref. No. 1)	2
7	Handle kit	5790-100-90	5792-100-90	5780-100-90	1
8	Fastener	*	*	*	4
9	Fastener	(see Ref. No. 1)	(see Ref. No. 1)	(see Ref. No. 1)	1
10	Wire cover	—	—	—	—
11	Seal	(see Ref. No. 32)	(see Ref. No. 32)	(see Ref. No. 32)	1
12	Upper end bell	—	—	—	—
13	Shaft/rotor	—	—	—	—
14	Shaft key	—	—	—	—
15	Drain plug	—	—	—	—
16	Motor case	—	—	—	—
17	Upper seal seat	(see Ref. No. 32)	(see Ref. No. 32)	(see Ref. No. 32)	1
18	Seal head	(see Ref. No. 32)	(see Ref. No. 32)	(see Ref. No. 32)	1
19	Lower seal seat	(see Ref. No. 32)	(see Ref. No. 32)	(see Ref. No. 32)	1
20	Seal	(see Ref. No. 32)	(see Ref. No. 32)	(see Ref. No. 32)	1
21	Casing kit	5790-001-95	5792-001-95	5780-001-98	1
22	Fastener	(see Ref. No. 21)	(see Ref. No. 21)	(see Ref. No. 21)	3
23	Seal	(see Ref. No. 32)	(see Ref. No. 32)	(see Ref. No. 32)	1
24	Impeller	(see Ref. No. 31)	(see Ref. No. 31)	(see Ref. No. 31)	1
25	Impeller washer	(see Ref. No. 31)	(see Ref. No. 31)	(see Ref. No. 31)	1
26	Impeller fastener	(see Ref. No. 31)	(see Ref. No. 31)	(see Ref. No. 31)	1
27	Base	(see Ref. No. 31)	(see Ref. No. 31)	(see Ref. No. 31)	1
28	Strainer kit	5790-170-90	5792-170-90	5780-170-90	1
29	Fastener	(see Ref. No. 28)	(see Ref. No. 28)	(see Ref. No. 28)	3
30	Fastener	(see Ref. No. 31)	(see Ref. No. 31)	(see Ref. No. 31)	3
31	⊕ Wearplate and impeller kit	5790-010-90	5792-010-90	5780-010-90	1
32	‡ Seal kit	5790-300-90	5792-300-90	5780-300-90	1

(—) Not available

(*) Standard hardware item, available locally

(~) Power cord/float kit includes Ref. Nos. 1, 2, 3, 5, 6

(⊕) Not shown. Wearplate and impeller kit includes Ref. Nos. 24, 25, 26, 27

(‡) Not shown. Seal kit includes Ref. Nos. 11, 17, 18, 19, 20, 23

Submersible Pumps

Drainage / Sump Series

Maintenance (Continued)

promised. Therefore, periodic seal replacement is recommended. Time interval between replacements will depend on abrasiveness of liquid being pumped, temperature, total accumulated runtime, etc.

IMPORTANT: Always replace seal head (Ref. No. 18) and both seal seats (Ref. Nos. 17 & 19) at same time to insure proper mating of components.

Refer to Figure 3.

1. Disassemble pump by following directions in both "Power Cord Replacement" and "Impeller Inspection / Replacement" sections.
2. With unit on it's side and wire cover, pump assembly, and impeller removed, lift shaft key (Ref. No. 14) from shaft/rotor (Ref. No. 13) using a pliers.
3. Clean rust and buildup from unit.
4. Drain oil from seal cavity by removing drain plug (Ref. No. 15) from motor case (Ref. No. 16). Then tip components overtop of a catch pan until oil is drained.
5. Remove three fasteners (Ref. No. 22) which attach casing (Ref. No. 21) to motor case and pry two

components apart with screwdriver.

6. Press on end of motor shaft to separate from motor case. Then carefully guide upper end bell (Ref. No. 12) along with shaft/rotor and bearing assembly out of motor case. Shaft seal head will now be free.

IMPORTANT: Shaft seal head (with spring) may have unique ends, and two seal seats may be different from one another also. Be sure to note size and color of each before disassembly so that new parts are installed in proper orientation.

7. Remove upper seal seat (Ref. No. 17) from motor case by using a screwdriver or dowel to press on seal from rear. Do the same for lower seal seat (Ref. No. 19) in casing.
8. Clean seal seat cavities before inserting new seals.
9. Carefully wipe polished surface of new seal seats with a clean cloth.
10. Wet outside of rubber portion of seal seats with a light coating of soapy water.
11. Press each new seal seat squarely into cavity in both motor case and casing. If seal seat does not press squarely into cavity, it can be adjusted into

place by pushing on it carefully with a piece of pipe or dowel. Always use a piece of cardboard between pipe and seal seat to avoid scratching seal seat. (This is a lapped surface and must be handled very carefully.)

12. After each seal seat is in place, insure that it is clean and has not been marred.
13. Using a clean cloth, wipe shaft and make certain that it is perfectly clean.
14. Carefully guide motor shaft through seal seat and use a press to seat bearing back into motor case.
15. Apply a light coating of soapy water to inside rubber portion of seal head and slide onto shaft (be sure to start correct end first).
16. Place casing back onto motor housing being careful to guide shaft and avoid damage to seal seat. Secure with fasteners.
17. Press lip seal back in place.
18. Refill cavity with oil through fill hole and reassemble in reverse order.