

Please read and save these instructions. Read carefully before attempting to assemble, install, operate or maintain the product described. Protect yourself and others by observing all safety information. Failure to comply with instructions could result in personal injury and/or property damage! Retain instructions for future reference.

# Mounting Brackets

## Description

This mounting bracket assembly is constructed in heavy steel plate to support the pump by the column to prevent tipping. It is made in two halves and comes with a template for marking the opening and bolt holes required for mounting the pump through the top of the tank or reservoir.

4410-90 mounting bracket is for use with pump Models 4410-95 and 4411-95.

4420-90 mounting bracket is for use with pump Models 4421-95 thru 4443-95.

## Unpacking

When unpacking mounting brackets, inspect carefully for any damage that may have occurred during transit. Check for missing or damaged parts.

## Assembly

If bracket is to be used on a pump that is already installed in a system it will be necessary to remove the first section of discharge piping.

1. Place two mounting brackets (Ref.

Nos. 1 & 2) and two column clamps on pump column with flange of bracket up and join them together using two fasteners assemblies (Ref. Nos. 5 & 6). Leave fasteners loose enough that bracket can be positioned on column.

**NOTE:** Two pieces of self-stick sponge tape (Ref. No. 4) are included. If column clamps do not clamp tightly onto column, apply sponge tape to inside of column clamps.

2. Rotate mounting bracket assembly so opening is over the discharge port of pump.
3. Insert first section of piping through bracket and connect it to pump and tighten.
4. Position bracket on column to desired location and tighten fasteners.
5. If it is necessary to modify top of tank or reservoir to accommodate bracket/pump assembly, mark opening for pump column and four 3/8 inch mounting holes using template supplied. Cut and drill top.
6. Place pump and bracket on tank or reservoir top and secure four corners with 1/4-20 cap screws, washers, and nuts.
7. Install balance of system.

**For Repair Parts, contact dealer where product was purchased.**

Please provide following information:

- Model number
- Serial number (if any)
- Part description and number as shown in parts list

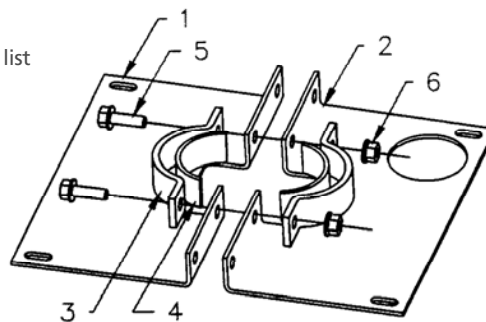

Figure 1 - Repair Parts Illustration

## Repair Parts List

Reference Number	Description	Part Number for Models:		Quantity
		4410-90	4420-90	
1	Mounting bracket	4445-042-00	4445-042-00	1
2	Mounting bracket with outlet	4445-043-00	4445-040-00	1
3	Column clamp	4445-044-00	4445-041-00	2
4	Sponge tape	*	*	2
5	Fastener with washer	*	*	2
6	Fastener	*	*	2
Δ	Template	4410-255-00	4410-255-00	1

(Δ) Not Shown; (\*) Standard hardware item, available locally.

4410-261-00

10/2001