

Please read and save this Repair Parts Manual. Read this manual and the General Operating Instructions carefully before attempting to assemble, install, operate or maintain the product described. Protect yourself and others by observing all safety information. The Safety Instructions are contained in the General Operating Instructions. Failure to comply with the safety instructions accompanying this product could result in personal injury and/or property damage! Retain instructions for future reference. AMT reserves the right to discontinue any model or change specifications at any time without incurring any obligation.

©2016 AMT Pump Company, A Subsidiary of The Gorman-Rupp Company, All Rights Reserved.

Periodic maintenance and inspection is required on all pumps to ensure proper operation. Unit must be clear of debris and sediment. Inspect for leaks and loose bolts. Failure to do so voids warranty.

# Small Straight Centrifugal Pedestal Pumps



Refer to pump manual 1808-635-00 for General Operating and Safety Instructions.

## DESCRIPTION

These pumps are for continuous duty, low pressure applications that do not require self-priming. Discharge port rotates 360° in 90° increments. Pumps incorporate a mechanical shaft seal and O-ring casing seal. All units for use with nonflammable, non-abrasive liquids compatible with pump component materials.

### STAINLESS STEEL UNITS (300 Series SS)

Pump construction is cast 316 stainless steel with shaft seal of stainless steel, carbon, ceramic, and Viton elastomers. Handle liquids from 40° to 200° F (4° to 93° C).

### BRONZE UNITS

Pump construction is cast bronze casing with cast 316 stainless steel impeller and pedestal. Includes shaft seal of stainless steel, carbon, ceramic and Viton elastomers. Handle liquids from 40° to 200° F (4° to 93° C). (Model 3682-97 has bronze casing and pedestal)

### CAST IRON UNITS (3682-95 ONLY)

Pumps are cast iron with cast 316 stainless steel impeller and bronze pedestal. Shaft seal is stainless steel, carbon, ceramic and Buna N elastomers. Handle liquids from 40° to 180° F (4° to 82°C).

## Specifications

Description	3682	3704	3694
Suction Inlet	3/4" NPT	1" NPT	1 1/4" NPT
Discharge Outlet	1/2" NPT	3/4" NPT	1" NPT
Shaft Diameter	5/8"	5/8"	5/8"
Keyway	3/16" x 1"	3/16" x 1"	3/16" x 1"
Dimensions (overall)	6 3/8" L x 5 1/8" W x 6 1/8" H	6" L x 6 5/8" W x 6 3/4" H	6 1/8" L x 6 5/8" W x 6 3/4" H
Weight (approximate)	10 lbs.	11 lbs.	13 lbs.

## Performance Chart

Model	Port Size	Pump RPM	BHP Required	GPM at Total Head in Feet						*Max. Head
				10'	20'	30'	40'	50'	60'	
3682	3/4" x 1/2"	3450	0.58	36	32	27	20	90	-	57 ft.
		3000	0.33	30	25	17	5	-	-	42 ft.
		2600	0.25	24	16	1	-	-	-	31 ft.
		1750	0.25	8	-	-	-	-	-	13 ft.
3704	1" x 3/4"	3450	1.13	57	51	43	35	21	0	60 ft.
		3000	0.65	48	39	30	15	-	-	46 ft.
		2600	0.25	37	21	4	-	-	-	32 ft.
		1750	0.25	17	-	-	-	-	-	14 ft.
3694	1 1/4" x 1"	3450	2.00	88	81	72	62	48	25	68 ft.
		3000	1.5	75	65	53	38	5	-	51 ft.
		2600	0.75	62	49	25	-	-	-	37 ft.
		1750	0.25	27	-	-	-	-	-	17 ft.

(\*) Shut-off; to convert to psi, divide by 2.31.

# Small Straight Centrifugal Pedestal Pumps

## MAINTENANCE

### ▲ WARNING

**Make certain that unit is disconnected from power source before attempting to service or remove any components!**

## MECHANICAL SEAL REPLACEMENT

Refer to Figure 1.

**IMPORTANT:** Always replace both seal seat (Ref. No.8) and seal head (Ref. No. 7) to insure proper mating of components! Also, impeller seal (Ref. No. 10) should be replaced anytime impeller fastener (Ref. No. 11) has been removed.

1. Remove fasteners (Ref. No. 14) connecting casing (Ref. No. 13) to pedestal (Ref. No. 5).
2. Remove casing and casing seal (Ref. No. 12).

### ▲ CAUTION

**Care should be taken not to "pinch" or "shave" casing seal between pedestal and casing.**

3. Use a box and/or socket wrench to remove impeller fastener. Remove impeller seal and impeller (Ref. No. 9). Seal seat can now be pried from impeller.

**IMPORTANT:** Care should be taken to ensure that same number and thickness of shim washers (Ref. No. 8A) are replaced behind impeller as was removed. Shim washers are located directly behind impeller and become loose as impeller is removed.

4. To free shaft assembly (Ref. No. 4), see "Bearing Housing Service".
5. After shaft assembly is removed, press seal head from pedestal.

### ▲ CAUTION

**The precision lapped faces on mechanical seal are easily damaged. Handle your replacement seal carefully. Do not touch polished seal faces.**

**IMPORTANT:** Be sure that shaft shoulder does not damage polished seal face.

6. Thoroughly clean all surfaces of seal seat cavity in pedestal and impeller.
7. While wearing clean gloves or using a clean light rag, press seal head squarely into pedestal recess, use cardboard washer (usually supplied with new seal), place over polished surface and use a piece of pipe or dowel rod to press in firmly, but gently. Avoid scratching polished face.
8. Dispose of cardboard washer. Check again to see that polished surface is free of dirt and all other foreign particles and that it has not been scratched or damaged.
9. Wet rubber portion of new seal seat with a light coating of soapy water. While wearing clean gloves or using a clean light rag, press seal seat squarely into impeller recess, use cardboard washer (usually supplied with new seal), place over polished surface and use a piece of pipe or dowel rod to press in firmly, but gently. Avoid scratching polished face.

**NOTE:** A short "run-in" period may be necessary to provide completely leak free seal operation.

10. Replace any shim washers which may have been removed in disassembly.
11. Screw impeller back in place, tightening until it is against shaft shoulder. Install impeller seal and impeller fastener.
12. Remount casing seal and casing on pedestal.

**IMPORTANT:** Always inspect casing seal (Ref. No. 12) whenever unit is disassembled. Replace when cracked or worn.

**IMPORTANT:** After pump is completely assembled it is necessary to rotate pump shaft by hand to check for striking of impeller. If striking or rubbing occurs, adjust impeller shims as required (see "Shim Adjustment").

## BEARING HOUSING SERVICE

1. Remove casing (Ref. No. 13) and impeller (Ref. No. 9) as described under "Mechanical Seal Replacement".
2. Remove shaft assembly (Ref. No. 4) by first removing snap ring (Ref. No. 1) and shims (Ref. No. 2). Push shaft assembly out of pedestal by rapping on threaded end of shaft with a soft mallet, or block of wood and a hammer. Slinger washer (Ref. No. 6) will come loose at this time.
3. Replace shaft assembly by sliding assembly into pedestal (be sure to align slinger washer), threaded end first. Push assembly completely in by gently tapping on keyway end of shaft with a soft mallet. Replace shims and snap ring.
4. Reassemble pump as described under "Mechanical Seal Replacement".

## SHIM ADJUSTMENT

When installing a replacement impeller (Ref. No. 9) or shaft assembly (Ref. No. 4), it may be necessary to adjust number of shims (Ref. No. 8A) to ensure proper running clearance between impeller and casing (Ref. No. 13). Proceed as follows:

**NOTE:** A proper running clearance is less than 0.010".

1. For impeller replacement, add one 0.010" shim in addition to those removed originally.
2. For shaft assembly replacement, add two 0.010" shims in addition to those removed during disassembly.
3. Reassemble pump using "Mechanical Seal Replacement" for reference.

**IMPORTANT:** Be sure that casing is snugly in place and check shaft to make sure it is turning freely. If it turns freely, check to be sure that pedestal (Ref. No. 5) and casing are fitted "metal to metal" where they meet on outside. If they are not "metal to metal" tighten fasteners (Ref. No. 14) and recheck shaft for free turning. Tighten carefully turning shaft while tightening so that bearings are not damaged in the event that too many shims were installed. If shaft seizes before fasteners are completely tight, disassemble pump and remove one 0.010" shim and repeat reassembly.



## For Repair Parts contact dealer where pump was purchased.

Please provide following information:

-Model Number

-Serial Number (if any)

Part description and number as shown in parts list

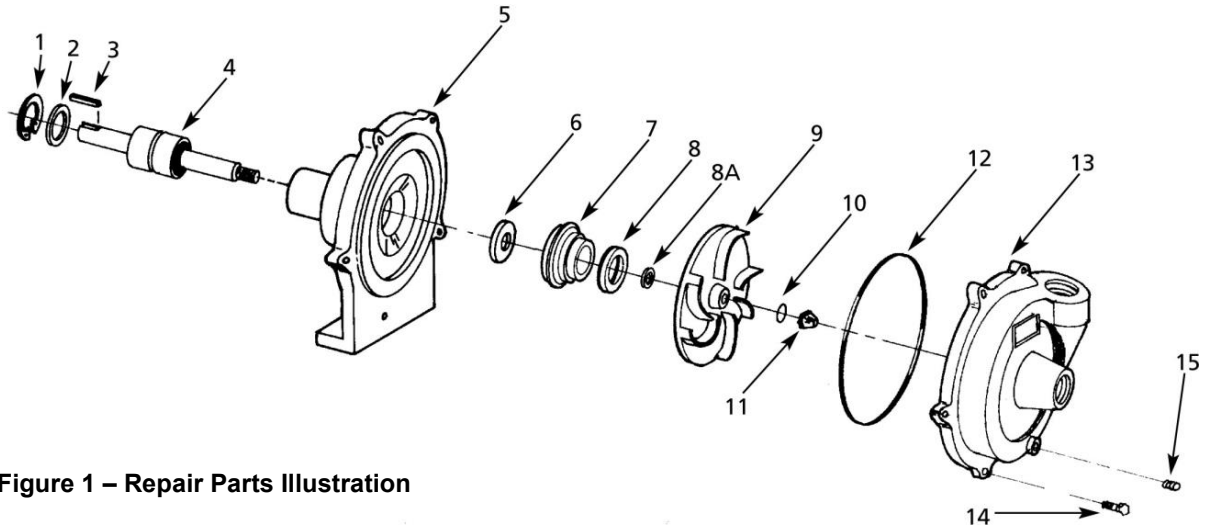

Figure 1 – Repair Parts Illustration

## Repair Parts List

Ref. No.	Description	Part Number for Models:			Qty.
		3682	3704	3694	
1	Snap Ring	1806-062-00	1806-062-00	1806-062-00	1
2	Bearing Shim Package	-for Cast Iron & Bronze Pumps 1696-003-90 -for Stainless Steel Pumps 1806-080-90	1696-003-90 1806-080-90	1696-003-90 1806-080-90	1
3	Shaft Key	1517-000-00	1517-000-00	1517-000-00	1
4	Shaft and Bearing Assembly	-for Cast Iron & Bronze Pumps 1509-140-90 -for Stainless Steel Pumps 3682-140-90	1509-140-90 3682-140-90	1509-140-90 3682-140-90	1
5	Pedestal	-Cast Iron (3682 ONLY) 3682-091-95 -Bronze 3682-090-98 -Stainless Steel 3682-090-98	Replace Pump 3694-090-09	Replace Pump 3694-090-09	1 1 1
(includes Ref. Nos. 1, 2, 3, 4 and 5)					
6	5/8" Slinger Washer (not required)	1534-000-00	1534-000-00	1534-000-00	1
7,8	◇ Seal Assembly, Buna-N	1640-161-92	1640-161-92	1640-161-92	1
	◇ Seal Assembly, Viton	1640-161-95	1640-161-95	1640-161-95	1
8A	Impeller Shim Kit	1806-044-90	1806-044-90	1806-044-90	1
9	Impeller	3680-010-09	3700-010-09	3690-010-09	1
10	O-ring, Buna-N	2105-036-00	2105-036-00	2105-036-00	1
	O-ring, Viton	2105-037-00	2105-037-00	2105-037-00	1
11	7/16" - 20 UNF SS Acorn Nut	1784-001-00	1784-001-00	1784-001-00	1
12	O-ring, Buna-N	1582-000-00	1582-000-00	1582-000-00	1
	O-ring, Viton	1532-000-00	1567-001-00	1567-001-00	1
13	Casing	-Cast Iron 3680-002-09 -Bronze 3680-004-09 -Stainless Steel 3680-001-09	N/A 3700-003-09	N/A 3690-003-09	1
14	1/4" - 20 UNC x 7/8" Hex Head Cap Screw	*	N/A	N/A	5
	5/16" - 18 UNC x 7/8" Hex Head Cap Screw	N/A	*	*	5
15	1/8" Pipe Plug	*	*	*	1

(\*) Standard Hardware Item, Available Locally

(◇) Seal assembly available as set only (includes seal head and seat).



AMT Pump Company  
(herein "AMT")  
400 Spring Street  
Royersford, PA 19468  
Phone: (610) 948-3800  
Fax: (610) 948-5300  
www.amtpump.com

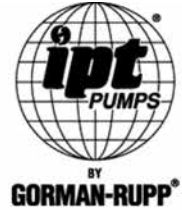

## General Information

**SALES POLICY:** AMT products are sold through our established Distributors. We do not sell direct to the consumer or organization not entitled to trade recognition. Therefore, possession of our catalogs and/or price list(s) does not infer an offer to sell.

**MINIMUM ORDER:** We appreciate your order, however, all orders are subject to a minimum \$35.00 net invoice charge (excluding freight). This applies to all pump and parts purchase orders.

**PRICES:** Prices are subject to change without notice. All orders accepted are subject to prices in effect at time of shipment.

**PAYMENT TERMS:** Terms, upon establishment of credit, are Net 30 days. Past due accounts may be subject to a service charge of 1.5% per month. Domestic or assignable letter of credit is required for all export trade.

**PAST DUE ACCOUNTS:** AMT reserves the right to withhold open account shipments on any past due account. Invoices are considered past due after thirty (30) days. In the interest of sound business, all orders are subject to approval of the Credit Department.

**SHIPPING INSTRUCTIONS:** All shipments will be made F.O.B. the factory. Where instructions for shipment do not appear on the order, the shipment will be made according to our best judgment. Full risk of loss (including transportation delays and losses) shall pass to the customer upon delivery of the products to the carrier at the F.O.B. point. When loss or delay occurs, primary responsibility for tracing rests with the customer. When there is LOSS or APPARENT VISIBLE DAMAGE to a shipment, when tendered for delivery, **DO NOT** give the carrier a clear receipt. Note such damage on the carrier's delivery receipt and **HAVE THE DRIVER SIGN THE RECEIPT.**

**PRODUCT REVISIONS:** AMT reserves the right to discontinue, change or improve its products or any portions thereof without being obligated to provide such a change or improvement for units sold and/or shipped prior to such a change or improvement.

**LEAD TIME:** Products designated "Quick Ship Product", also referred to as "QSP" will normally be shipped within 24 hours of receipt of a non-cancellable purchase order. Only limited quantities of "QSP" pumps are available.

**STANDARD LEAD TIME:** Lead time is two weeks for all non "QSP" product. AMT reserves the right to revise lead times as required due to availability of materials and all other causes beyond our control.

**VIP SHIPMENT:** Select AMT and IPT branded pumps are available for next day shipment for non-QSP (Quick Ship Products) items and subjected to a specific model surcharge per unit noted in the respective price book. Requires calling for availability, confirmation and a non-cancellable purchase order or credit card payment prior to shipment. The expedited shipping charges are an additional cost added separately from the VIP charges per item. AMT reserves the right to revise lead times as required due to availability of materials and all other causes beyond our control. QSP quantities are limited as determined by AMT.

ALL purchase orders must be submitted via hard copy sent to AMT customer service department by fax, EDI or e-mail.

**RETURN GOODS POLICY:** Goods shall not be returned without a return goods authorization number (RGA) issued by AMT customer service. The RGA number must be listed on the packing list. Only current model and part numbers with a valid date code may be returned (within one year from date of purchase). **A 20% restocking and packaging charge will apply to all returns. All shipping charges must be pre-paid. No exceptions.**

**ORDER CHANGES BY CUSTOMER:** Orders in process may not be changed except with written consent and may be subject to special charges.

## 12 Month Limited Warranty

### EXTENT AND DURATION OF LIMITED WARRANTY

**Coverage:** AMT Pump Company (herein "AMT") or IPT Pumps by Gorman-Rupp (herein "IPT") or Gorman-Rupp Industries Division of the The Gorman-Rupp Company, Patterson, or the Gorman-Rupp Company (herein referred to as "G-R Unit") each individually warrants that its products and parts shall be free from defects in material and workmanship for twelve (12) months from the date of purchase by the original end user when installation is made and maintenance is performed in accordance with G-R Unit's recommendations. Wear and tear resulting from use and items normally consumed in use are not covered.

### EXCEPTIONS

( A ) This Limited Warranty shall not apply to mechanical seals in AMT or IPT pumps and the following products and parts: engines, motors, trade accessories and all other products, components, parts and materials not manufactured by the G-R Units. These items may, however, be covered by the warranties of their respective manufacturers. ( B ) This warranty does not extend to or apply to any unit which has been repaired or altered at any place other than by a G-R Unit, or by persons not expressly approved by a G-R Unit to make repairs or alterations, nor to any unit the serial number, model number or identification of which has been removed, defaced or altered. ( C ) This warranty does not extend to any product manufactured by a G-R Unit, which has been subjected to mis-use, neglect, accident, improper installation, or use in violation of instructions furnished by a G-R Unit. ( D ) Pump Kits: This warranty does not extend to any product sold by a G-R Unit unassembled as a Pump Kit. Pump Kits are warranted against defects in material and workmanship for 60 days from the date of shipment from a G-R Unit. Any Pump Kit parts deemed defective by a G-R Unit will be replaced free of charge within 60 days of shipment. Pump Kits are not returnable for credit.

### LIMITATIONS

**THE G-R UNITS' SOLE AND EXCLUSIVE WARRANTY WITH RESPECT TO THEIR PRODUCTS AND PARTS IS THIS LIMITED WARRANTY. THIS LIMITED WARRANTY IS IN LIEU OF ALL OTHER EXPRESS AND/OR IMPLIED WARRANTIES, INCLUDING IMPLIED WARRANTIES OF MERCHANTABILITY AND FITNESS FOR PARTICULAR PURPOSE.**

### EXCLUSIVE REMEDY AND DAMAGES

The sole and exclusive remedy for breach of this Warranty by a G-R Unit and the entire extent of its liability for such breach or for damages arising from the use of the products and parts covered under this Limited Warranty, shall be as follows:

- Repair or Replacement:** If inspection shows that any G-R Unit product or part covered under this Limited Warranty is defective in materials or workmanship, the G-R Unit shall repair or replace the defective or non-conforming product or part without charge, whichever the G-R Unit chooses. You must have properly maintained and used the product or part claimed to be defective in accordance with the maintenance schedule or manual, which comes with the product. No allowance will be made for labor, installation, removal, transportation or other charges incurred by you in connection with such repair or replacement.
- To obtain the above remedy:

- Immediately notify the G-R Unit upon discovery of the claimed defect in materials or workmanship and provide the serial number or date code of the product and/or part(s) or provide the G-R Unit with the invoice or bill of sale referencing the product by no later than the expiration date of the warranty period.
- The G-R Unit will advise whether inspection will be necessary and how whether repair or replacement will be made. If inspection by the G-R Unit is necessary, the pump or defective part must be sent freight pre-paid to the G-R Unit. Return shipment will be F.O.B. the G-R Unit's plant.
- Return Goods Authorization Requirement:** No product will be accepted for return or replacement without the prior written authorization of the G-R Unit. Upon such authorization, and in accordance with instructions from the G-R Unit, the product will be returned to the G-R Unit, shipping charges prepaid by the Buyer.

- Damages:** The G-R Unit's liability for damages for breach of this Limited Warranty shall not exceed the amount of the purchase price of the product or part(s) in respect to which Such damages are claimed. **IN NO EVENT SHALL THE G-R UNITS BE LIABLE FOR INCIDENTAL, CONSEQUENTIAL OR SPECIAL DAMAGES FOR BREACH OF THIS LIMITED WARRANTY.**

Some states do not allow the exclusion or limitation of incidental or consequential damages, so the above limitation or exclusion may not apply to you. This Limited Warranty gives you specific legal rights, and you may also have other rights, which vary from state to state.