

Please read and save this Repair Parts Manual. Read this manual and the General Operating Instructions carefully before attempting to assemble, install, operate or maintain the product described. Protect yourself and others by observing all safety information. The Safety Instructions are contained in the General Operating Instructions. Failure to comply with the safety instructions accompanying this product could result in personal injury and/or property damage! Retain instructions for future reference. AMT reserves the right to discontinue any model or change specifications at any time without incurring any obligation.

©2015 AMT Pump Company, A Subsidiary of The Gorman-Rupp Company, All Rights Reserved.

Periodic maintenance and inspection is required on all pumps to ensure proper operation. Unit must be clear of debris and sediment. Inspect for leaks and loose bolts. Failure to do so voids warranty.

# Bronze Marine Pump

Refer to pump manual 1808-634-00 for General Operating and Safety Instructions.



## DESCRIPTION

This non self-priming, low pressure, centrifugal pump is intended for liquid transfer, re-circulation and wash down applications in marine environments where no suction lift is required. Pump is sized for saltwater (1.03 specific gravity) and features provisions for the installation of an automatic seal wash. This may extend shaft seal life by retarding salt crystallization on seal wear face. Seal wash hose not included. For use with nonflammable, non-abrasive liquids compatible with pump component materials. Units are equipped with a TEFC (Totally Enclosed Fan Cooled), ball bearing, splash protected, capacitor start, 4 pole motor. Thermal protection not provided. The motor has ON/OFF switch, standard plug and six foot cord.

## INSTALLATION

Because of crystallization and erosive material on shaft seal (Ref. No. 11), installation of a seal wash is recommended to avoid premature leaks. Two types may be used, a recirculated liquid type or a clean liquid type. Sometimes a periodic seal cleaning is unavoidable.

Use pipe or hose to connect drain port on front of casing (Ref. No. 15) to seal flush port on side of adapter (Ref. No. 9). Whenever pump is running, this recirculation line will flush seal.

Or, connect a line supplying clean liquid to seal flush port on adapter. Always use an in-line check valve on this line. Flush as required.

## MAINTENANCE

### ⚠ WARNING

**Disconnect from power source before servicing or inspecting the pump for any reason. Failure to do so could result in fatal electrical shock!**

### MECHANICAL SEAL REPLACEMENT

Refer to Figures 1, 2 and 3.

**IMPORTANT:** Always replace both the seal seat and the seal head (Ref. No. 11) to ensure proper matching of components!

1. Unthread cap screws (Ref. No. 2) and remove casing (Ref. No. 15) and o-ring (Ref. No. 14).
2. Unscrew impeller (Ref. No. 13) from shaft (Ref. No. 7). To keep the shaft from turning, remove three screws holding the motor fan guard and remove the guard. Loosen the screw clamping the fan to the motor shaft and remove the fan. When the fan is removed, the shaft can be held using vise grip pliers or other suitable means.
3. Remove the three hex nuts (Ref. No. 8) and remove the adapter (Ref. No. 9).
4. Lay the adapter face down on a flat stable surface and press the seal cartridge from the adapter.
5. Pry the seal seat from the rear of the impeller with a screwdriver or other suitable means.

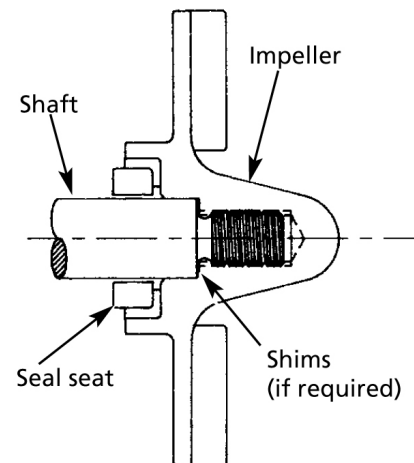

Figure 1 - Mechanical Seal Replacement

6. Clean the recess in the adapter for the seal cartridge and the recess in the impeller for the seal seat before inserting any new parts.
7. Inspect the ceramic face of the seal seat and carbon face of the cartridge to insure they are clean and not marred.

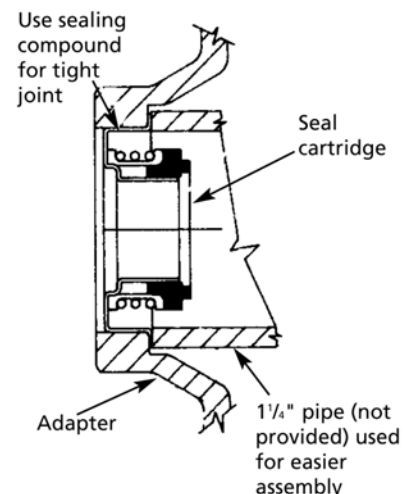

Figure 2 - Mechanical Seal Replacement

# Bronze Marine Pump

8. Press the new cartridge into the recess in the adapter. A sealing compound (such as silicon or Permatex) may be used to assure a water tight fit on the outside of the cartridge.
9. Wet the rubber portion of the ceramic seat with a light coating of soapy water.
10. Press the seal seat squarely into the cavity in the impeller. If the seal seat does not press squarely into the cavity, it can be adjusted in place by pushing on it with a piece of pipe. Always use a piece of cardboard between the pipe and the seal seat to avoid scratching the face of the seal seat. This is a lapped surface and must be handled very carefully.
11. After the seal seat is in place, check that it is clean and has not been scratched or cracked.
12. Mount the adapter on the motor mounting face making sure the seal flush part is approximately in the 1 o'clock position when facing the pump.
13. Replace the impeller and tighten, make certain any shims (Ref. No. 12) previously used are in place.
14. Place the o-ring seal on the adapter and replace the casing. Replace and tighten the cap screws.
15. Before proceeding to replace the fan and fan guard, turn the shaft to make certain the impeller turns free and is not rubbing the casing.
16. If the shaft turns free replace the fan and fan guard. If it rubs the casing follow steps 1 and 2. Remove any shims from the shaft and reassemble following steps 13 thru 16.

## SHIM ADJUSTMENT

When installing a replacement impeller (Ref. No. 13) or motor (Ref. No. 1), it may be necessary to adjust the number of shims (Ref. No. 12) to ensure proper running clearance between the impeller and the casing. Proceed as follows:

**NOTE:** A proper running clearance is less than 0.010".

1. For impeller replacement, add one 0.010" shim in addition to those removed originally.
2. For motor replacement, add two 0.010" shims in addition to the shims removed during disassembly.
3. Reassemble the pump as described in steps 13 thru 16.

**IMPORTANT:** Be sure that the casing is snugly in place and check the shaft to make sure it is turning freely. If it turns freely, check to be sure that the adapter and casing are fitted tight together. If they are not, tighten the fasteners (Ref. No. 2) and recheck the shaft for free turning. Tighten carefully, turning the shaft while tightening so that the motor bearings are not damaged in the event that too many shims were installed. If shaft seizes before fasteners are completely tight, disassemble the pump and remove one shim and repeat reassembly.



# Bronze Marine Pump

**For Repair Parts contact dealer where pump was purchased.**

Please provide following information:

- Model Number
- Serial Number (if any)

Part description and number as shown in parts list

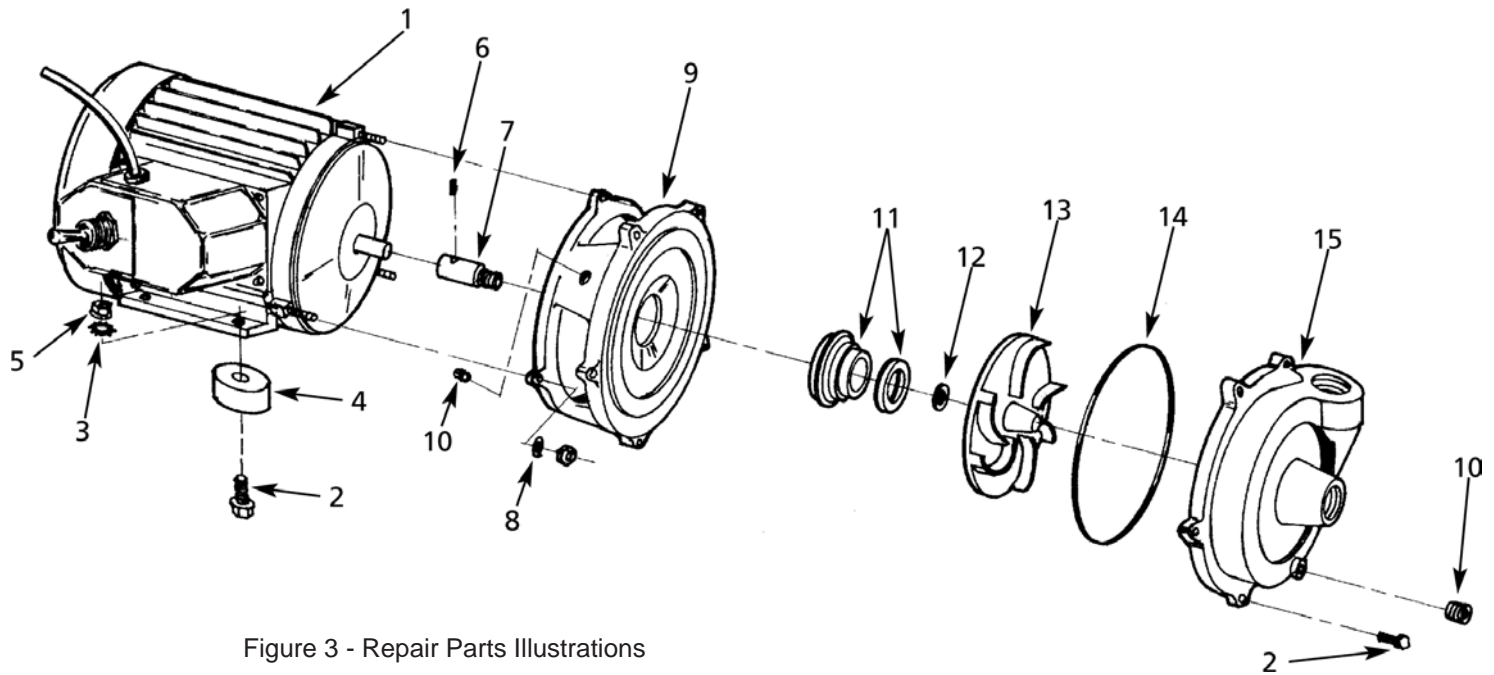

Figure 3 - Repair Parts Illustrations

## Repair Parts List

Ref No.	Description	Part Number for Model	
		3670-94	Qty
1	Motor	1626-017-00	1
2	Fastener	1718-001-00	9
3	Washer	1766-020-00	4
4	Rubber Foot	1508-000-00	4
5	Nut	1774-000-00	4
6	Fastener	1736-005-00	2
7	Stub Shaft	3670-140-00	1
8	Nut	1772-012-00	3
9	Adapter	3670-033-00	1
10	1/8" NPT Pipe Plug	1768-000-00	2
11	Seal Assembly - Buna N	1640-161-92	1
12	Shim Kit	1806-044-90	1
13	Impeller	3680-012-00	1
14	Casing O-Ring - Buna N	1582-000-00	1
15	Casing	3680-004-09	1





AMT Pump Company  
(herein "AMT")  
400 Spring Street  
Royersford, PA 19468  
Phone: (610) 948-3800  
Fax: (610) 948-5300  
www.amtpump.com

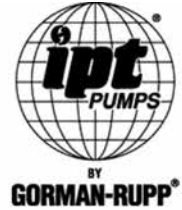

## General Information

**SALES POLICY:** AMT products are sold through our established Distributors. We do not sell direct to the consumer or organization not entitled to trade recognition. Therefore, possession of our catalogs and/or price list(s) does not infer an offer to sell.

**MINIMUM ORDER:** We appreciate your order, however, all orders are subject to a minimum \$35.00 net invoice charge (excluding freight). This applies to all pump and parts purchase orders.

**PRICES:** Prices are subject to change without notice. All orders accepted are subject to prices in effect at time of shipment.

**PAYMENT TERMS:** Terms, upon establishment of credit, are Net 30 days. Past due accounts may be subject to a service charge of 1.5% per month. Domestic or assignable letter of credit is required for all export trade.

**PAST DUE ACCOUNTS:** AMT reserves the right to withhold open account shipments on any past due account. Invoices are considered past due after thirty (30) days. In the interest of sound business, all orders are subject to approval of the Credit Department.

**SHIPPING INSTRUCTIONS:** All shipments will be made F.O.B. the factory. Where instructions for shipment do not appear on the order, the shipment will be made according to our best judgment. Full risk of loss (including transportation delays and losses) shall pass to the customer upon delivery of the products to the carrier at the F.O.B. point. When loss or delay occurs, primary responsibility for tracing rests with the customer. When there is LOSS or APPARENT VISIBLE DAMAGE to a shipment, when tendered for delivery, **DO NOT** give the carrier a clear receipt. Note such damage on the carrier's delivery receipt and **HAVE THE DRIVER SIGN THE RECEIPT.**

**PRODUCT REVISIONS:** AMT reserves the right to discontinue, change or improve its products or any portions thereof without being obligated to provide such a change or improvement for units sold and/or shipped prior to such a change or improvement.

**LEAD TIME:** Products designated "Quick Ship Product", also referred to as "QSP" will normally be shipped within 24 hours of receipt of a non-cancellable purchase order. Only limited quantities of "QSP" pumps are available.

**STANDARD LEAD TIME:** Lead time is two weeks for all non "QSP" product. AMT reserves the right to revise lead times as required due to availability of materials and all other causes beyond our control.

**VIP SHIPMENT:** Select AMT and IPT branded pumps are available for next day shipment for non-QSP (Quick Ship Products) items and subjected to a specific model surcharge per unit noted in the respective price book. Requires calling for availability, confirmation and a non-cancellable purchase order or credit card payment prior to shipment. The expedited shipping charges are an additional cost added separately from the VIP charges per item. AMT reserves the right to revise lead times as required due to availability of materials and all other causes beyond our control. QSP quantities are limited as determined by AMT.

ALL purchase orders must be submitted via hard copy sent to AMT customer service department by fax, EDI or e-mail.

**RETURN GOODS POLICY:** Goods shall not be returned without a return goods authorization number (RGA) issued by AMT customer service. The RGA number must be listed on the packing list. Only current model and part numbers with a valid date code may be returned (within one year from date of purchase). **A 20% restocking and packaging charge will apply to all returns. All shipping charges must be pre-paid. No exceptions.**

**ORDER CHANGES BY CUSTOMER:** Orders in process may not be changed except with written consent and may be subject to special charges.

## 12 Month Limited Warranty

### EXTENT AND DURATION OF LIMITED WARRANTY

**Coverage:** AMT Pump Company (herein "AMT") or IPT Pumps by Gorman-Rupp (herein "IPT") or Gorman-Rupp Industries Division of the The Gorman-Rupp Company, Patterson, or the Gorman-Rupp Company (herein referred to as "G-R Unit") each individually warrants that its products and parts shall be free from defects in material and workmanship for twelve (12) months from the date of purchase by the original end user when installation is made and maintenance is performed in accordance with G-R Unit's recommendations. Wear and tear resulting from use and items normally consumed in use are not covered.

### EXCEPTIONS

( A ) This Limited Warranty shall not apply to mechanical seals in AMT or IPT pumps and the following products and parts: engines, motors, trade accessories and all other products, components, parts and materials not manufactured by the G-R Units. These items may, however, be covered by the warranties of their respective manufacturers. ( B ) This warranty does not extend to or apply to any unit which has been repaired or altered at any place other than by a G-R Unit, or by persons not expressly approved by a G-R Unit to make repairs or alterations, nor to any unit the serial number, model number or identification of which has been removed, defaced or altered. ( C ) This warranty does not extend to any product manufactured by a G-R Unit, which has been subjected to mis-use, neglect, accident, improper installation, or use in violation of instructions furnished by a G-R Unit. ( D ) Pump Kits: This warranty does not extend to any product sold by a G-R Unit unassembled as a Pump Kit. Pump Kits are warranted against defects in material and workmanship for 60 days from the date of shipment from a G-R Unit. Any Pump Kit parts deemed defective by a G-R Unit will be replaced free of charge within 60 days of shipment. Pump Kits are not returnable for credit.

### LIMITATIONS

**THE G-R UNITS' SOLE AND EXCLUSIVE WARRANTY WITH RESPECT TO THEIR PRODUCTS AND PARTS IS THIS LIMITED WARRANTY. THIS LIMITED WARRANTY IS IN LIEU OF ALL OTHER EXPRESS AND/OR IMPLIED WARRANTIES, INCLUDING IMPLIED WARRANTIES OF MERCHANTABILITY AND FITNESS FOR PARTICULAR PURPOSE.**

### EXCLUSIVE REMEDY AND DAMAGES

The sole and exclusive remedy for breach of this Warranty by a G-R Unit and the entire extent of its liability for such breach or for damages arising from the use of the products and parts covered under this Limited Warranty, shall be as follows:

- Repair or Replacement:** If inspection shows that any G-R Unit product or part covered under this Limited Warranty is defective in materials or workmanship, the G-R Unit shall repair or replace the defective or non-conforming product or part without charge, whichever the G-R Unit chooses. You must have properly maintained and used the product or part claimed to be defective in accordance with the maintenance schedule or manual, which comes with the product. No allowance will be made for labor, installation, removal, transportation or other charges incurred by you in connection with such repair or replacement.
- To obtain the above remedy:

- Immediately notify the G-R Unit upon discovery of the claimed defect in materials or workmanship and provide the serial number or date code of the product and/or part(s) or provide the G-R Unit with the invoice or bill of sale referencing the product by no later than the expiration date of the warranty period.
- The G-R Unit will advise whether inspection will be necessary and how whether repair or replacement will be made. If inspection by the G-R Unit is necessary, the pump or defective part must be sent freight pre-paid to the G-R Unit. Return shipment will be F.O.B. the G-R Unit's plant.
- Return Goods Authorization Requirement:** No product will be accepted for return or replacement without the prior written authorization of the G-R Unit. Upon such authorization, and in accordance with instructions from the G-R Unit, the product will be returned to the G-R Unit, shipping charges prepaid by the Buyer.

- Damages:** The G-R Unit's liability for damages for breach of this Limited Warranty shall not exceed the amount of the purchase price of the product or part(s) in respect to which Such damages are claimed. **IN NO EVENT SHALL THE G-R UNITS BE LIABLE FOR INCIDENTAL, CONSEQUENTIAL OR SPECIAL DAMAGES FOR BREACH OF THIS LIMITED WARRANTY.**

Some states do not allow the exclusion or limitation of incidental or consequential damages, so the above limitation or exclusion may not apply to you. This Limited Warranty gives you specific legal rights, and you may also have other rights, which vary from state to state.