

Please read and save this Repair Parts Manual. Read this manual and the General Operating Instructions carefully before attempting to assemble, install, operate or maintain the product described. Protect yourself and others by observing all safety information. The Safety Instructions are contained in the General Operating Instructions. Failure to comply with the safety instructions accompanying this product could result in personal injury and/or property damage! Retain instructions for future reference. AMT reserves the right to discontinue any model or change specifications at any time without incurring any obligation.

©2015 AMT Pump Company, A Subsidiary of The Gorman-Rupp Company, All Rights Reserved.

Periodic maintenance and inspection is required on all pumps to ensure proper operation. Unit must be clear of debris and sediment. Inspect for leaks and loose bolts. Failure to do so voids warranty.

3-Inch Solids-Handling Pumps



Refer to pump manual 1808-633-00 for General Operating and Safety Instructions.

DESCRIPTION

These centrifugal pumps are high capacity, engine driven, self-priming (to 20 ft. lift), portable units, shipped completely assembled. Equipped with precision lapped mechanical seal to reduce the likelihood of leakage, and a clog resistant cast iron impeller and wear plate capable of handling solids up to 3/4" in diameter. Suction and discharge ports are 3" NPT pipe thread. Pumps are designed for operation involving irrigation and dewatering of excavations, basements, etc. Handle liquids from 40° to 180° (4° to 82° C). For use with nonflammable, non-abrasive liquids compatible with pump component materials. Pumps are constructed of cast iron with either Buna-N or Viton mechanical seal components (see specifications). Viton is recommended for pumping alachlor herbicides (e.g. Monsanto Lasso®) or other compatible liquids.

MAINTENANCE

▲ WARNING

Always disconnect battery cables and spark plug wire from spark plug before performing any maintenance operation requiring disassembly of the pump.

MECHANICAL SEAL REPLACEMENT

Refer to figures 1 and 2.

NOTE: Always replace seal assembly (Ref. No. 7) and shaft sleeve (Ref. No. 8) to ensure proper mating of mechanical seal components (models 327A and 327B have no shaft sleeve).

1. Remove pump casing (Ref. No. 3), gasket (Ref. No. 9) and impeller (Ref. No. 5).
2. Remove the shaft sleeve with the seal head on it.
3. Remove seal head from rear of impeller.
4. Remove the adapter (Ref. No. 10) and push seal seat from adapter recess with a screwdriver.
5. Thoroughly clean all surfaces of the adapter recess.
6. Using a clean cloth, wipe the polished surface of the seal head.
7. Wet the rubber portion of the new seal with a light coating of soapy water. Press seal seat squarely into adapter recess. Avoid scratching the white ceramic surface.

NOTE: Handle all seal parts with extreme care and attention to keeping them clean. Do not touch seal faces (either ceramic or carbon) with your hands. Do not put lubricants of any kind on seal faces. This can cause the seal to leak.

8. Inspect the ceramic face of the seal seat and carbon face of the seal head to ensure they are clean and not marred.
9. Wet the inside rubber portion of the new seal head with a light coating of soapy water. Slide head onto shaft sleeve. Slip the shaft sleeve with seal head onto the engine shaft.

IMPORTANT: Before installing new shaft sleeve, apply a bead of non-hardening, pliable sealant (such as Permatex® Form-A-Gasket® No. 2) to motor shaft shoulder.

10. Wet the inside rubber portion of the new seal head with a light coating of soapy water. Slide head onto the rear of impeller.

NOTE: Reinstall any shims or spacers that may have been removed onto engine shaft or into impeller before installing impeller.

11. Screw impeller back in place, tightening until it is against the end of the engine shaft.
12. Replace adapter gasket and casing and fasten with eight cap screws.
13. After assembly, turn engine shaft by hand slowly using recoil

starter to check for striking of the impeller on the casing. If striking or rubbing occurs, adjust impeller shims (see Shim Adjustment) as required and reconnect spark plug wire and battery cables.

14. A short "run-in" period may be necessary to provide completely leak-free seal operation.

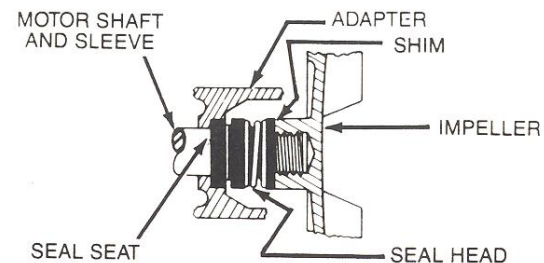

Figure 1 – Mechanical Seal

IMPELLER REPLACEMENT

Impeller (Ref. No. 5) is subject to wear only by abrasive action of sandy or dirty fluid. If badly worn, all these parts can be replaced easily and the pump thus restored to full efficiency.

NOTE: When the clearance between the impeller exceeds 1/16" at the face of the impeller or 1/8" on the outside diameter of the impeller, it may be necessary to take corrective action. The increased clearance can cause lengthened priming times and reduced pumping capacity. If both the priming and capacity of your unit are satisfactory for your application, it is recommended that no corrective maintenance be performed regardless of what clearances on your unit may have developed, since the increased clearances in themselves are not generally harmful to your pump.

Normally, new pump clearances can be restored by simply shimming behind the impeller (add shim washers, Ref. No. 6). If the diameter of the impeller is badly worn or if 1/16" shim washers do not restore clearances to less than the 1/16" face dimension and/or the 1/8" diametral clearance, it is recommended that the impeller be replaced.

3-Inch Solids-Handling Pumps

SHIM ADJUSTMENT

When installing a replacement impeller or mechanical seal, it may be necessary to vary the number of shims (Ref. No. 6) that will be required. This is easily done by adding one 0.010" shim more than was removed and reassembling the pump as described. Ensure that the casing is snugly in place and check the shaft to make sure it is turning freely. If it turns freely, check to ensure that the adapter (Ref. No. 10) and the casing (Ref. No. 3) are tighten the fastener (Ref. No. 16) and tighten carefully, turning shaft while tightening. If shaft seizes before fasteners are completely tight, disassembly pump and remove one shim and repeat reassembly. If any time during the above operation the shaft does not turn free, or a metal-to-metal strike can be heard or felt when turning the shaft, follow the procedure indicated above and repeat the procedure. The above procedure ensures that the pump will have the proper running clearance (less than 0.010") between the impeller and casing and perform like a new unit.

FLAPPER VALVE/DISCHARGE PORT GASKET REPLACEMENT

Remove bolts connecting plate to casing. Remove flapper valve or gasket. Inspect surface of both casing and plate to be free with debris or dirt/rust. Clean off if necessary. Install new flapper valve or gasket with original bolts.

For Repair Parts contact dealer where pump was purchased.

Please provide following information:

- Model Number
- Serial Number (if any)
- Part description and number as shown in parts list

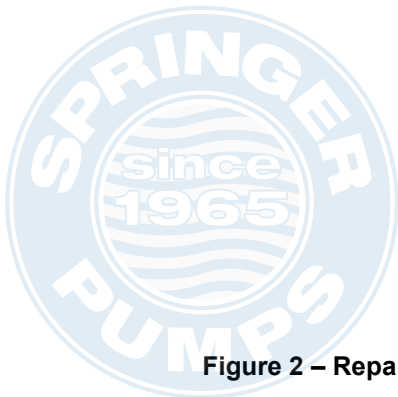
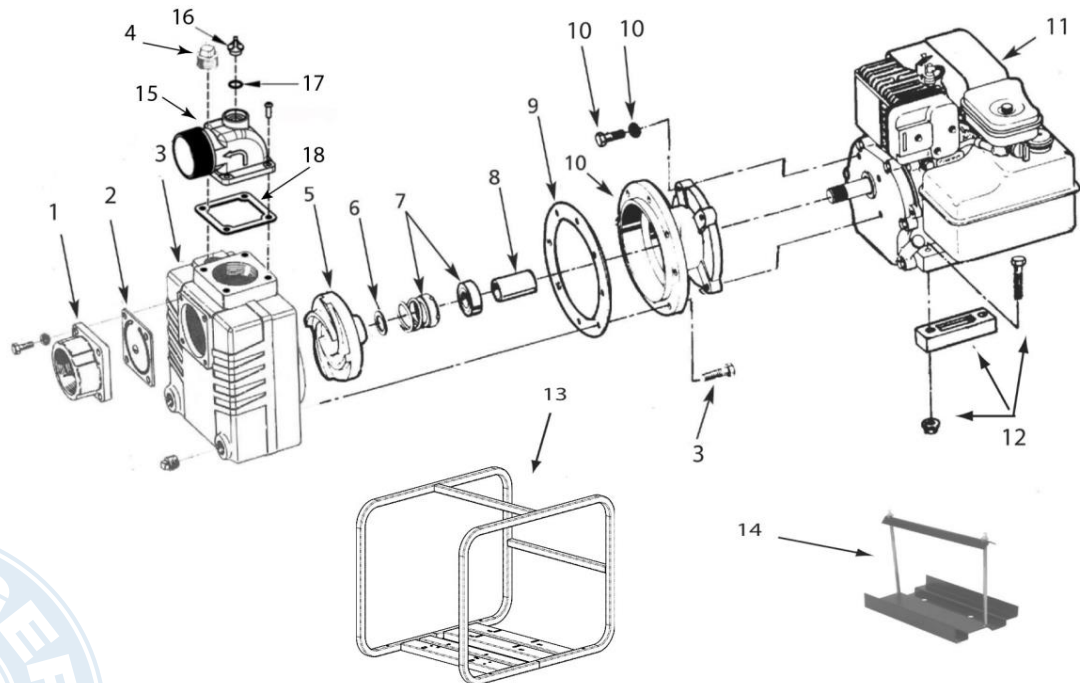

Figure 2 – Repair Parts Illustration

Repair Parts List

Ref. No.	Description	Part Number for Models:			Qty.
		327 Series 5/8" Shaft	327 Series 3/4" Shaft	339 Series 1" Shaft	
1	Suction Plate Kit (includes bolts)	3270-050-95	3270-050-95	3270-050-95	1
2	Flapper Valve Kit – Buna-N	1694-000-90	1694-000-90	1694-000-90	1
	Flapper Valve Kit - Viton	2874-071-90	2874-071-90	2874-071-90	1
3	Casing Kit- Buna-N	3270-003-95	3270-003-95	3270-003-95	1
	Casing Kit - Viton	3270-002-95	3270-002-95	3270-002-95	1
	(includes Ref. Nos. 1, 2, 3, & 4)				1
4	NPT Pipe Plug	Incl. w/ Ref. 4	Incl. w/ Ref. 4	Incl. w/ Ref. 4	3
5	Impeller Kit - Gasoline Models	3120-010-95	327A-010-95	2870-010-95	1
	Impeller Kit - Diesel Models	3120-010-95	N/A	3391-010-95	1
6	Shim Kit	1658-000-90	3827-172-90	1656-000-90	1
7	†Shaft Seal Assembly - Buna-N	1640-162-90	1641-164-00	1640-163-90	1
	†Shaft Seal Assembly - Viton	1640-162-91	1641-163-00	1640-163-91	1
8	Shaft Sleeve	1483-140-09	N/A	1555-140-03	1
9	Gasket Kit - Buna-N	327B-300-90	327B-300-90	327B-300-90	1
	Gasket Kit - Viton	327A-300-90	327A-300-90	327A-300-90	1
	(includes Ref. Nos. 2, 9, 16, 17, & 18)				
10	Adapter Kit	3120-030-95	327A-030-95	2870-031-95	1
	Adapter Kit – Hatz Diesel 1B30	N/A	N/A	3391-03Z-95	1
11	Engine: B&S 206CC, 3270-95	1639-049-00	N/A	N/A	1
	Engine: Hatz Diesel, 3270-D5	1630-020-90	N/A	N/A	1
	Engine: GC160, 327A-V5 & 327B-95	N/A	1639-042-00	N/A	1
	Engine: B&S 305CC, 3390-95	N/A	N/A	1639-024-00	1
	Engine: Honda GX270, 3993-V5	N/A	N/A	1639-026-00	1
	Engine: Honda GX270 with E-Start, 3391-V5	N/A	N/A	1639-028-00	1
	Engine: Hatz1B30, 3391-Z5	N/A	N/A	1630-030-00	1
	Engine: Yanmar Diesel with E-Start, 3391-D5	N/A	N/A	Discontinued	1
12	Frame Mount Kit	Incl. w/ Ref. 13	Incl. w/ Ref. 13	Incl. w/ Ref. 13	1
	Frame Mount Kit – Hatz Diesel 1B30	N/A	N/A	3391-10Z-90	1
13	Frame Kit	3120-105-K0	3120-105-K0	1696-100-K0	1
	(includes Ref. No. 12)				
14	Battery Tray Kit (E-Start Models Only)	N/A	N/A	1696-BAT-K0	1
15	Discharge Plate Kit (includes bolts)	3G5X-080-95	3G5X-080-95	3G5X-080-95	1
	(requires Gasket in Ref. No. 18)				
16	Fill Plug w/ O-Ring Kit – Buna-N	3SXB-170-90	3SXB-170-90	3SXB-170-90	1
	Fill Plug w/ O-Ring Kit – Viton	3SXV-170-90	3SXV-170-90	3SXV-170-90	1
17	O-Ring	Incl. w/ Ref. 9 or 16	Incl. w/ Ref. 9 or 16	Incl. w/ Ref. 9 or 16	1
18	Gasket Discharge	Incl. w/ Ref. 9	Incl. w/ Ref. 9	Incl. w/ Ref. 9	1
△	3" NPT Pipe Nipple Kit	C367-90	C367-90	C367-90	1
△	Wheel Kit (optional)	C402-99	C402-99	C402-99	1
△	NPT Suction Strainer	C519-90	C519-90	C519-90	1

(*) Standard Hardware Item, Available Locally

(†) Seal assembly available as set only (includes seal head and seat).

(△) Not Shown

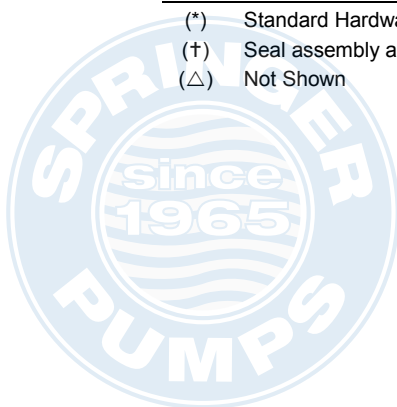



AMT Pump Company
(herein "AMT")
400 Spring Street
Royersford, PA 19468
Phone: (610) 948-3800
Fax: (610) 948-5300
www.amtpump.com

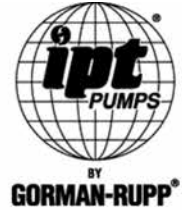

General Information

SALES POLICY: AMT products are sold through our established Distributors. We do not sell direct to the consumer or organization not entitled to trade recognition. Therefore, possession of our catalogs and/or price list(s) does not infer an offer to sell.

MINIMUM ORDER: We appreciate your order, however, all orders are subject to a minimum \$35.00 net invoice charge (excluding freight). This applies to all pump and parts purchase orders.

PRICES: Prices are subject to change without notice. All orders accepted are subject to prices in effect at time of shipment.

PAYMENT TERMS: Terms, upon establishment of credit, are Net 30 days. Past due accounts may be subject to a service charge of 1.5% per month. Domestic or assignable letter of credit is required for all export trade.

PAST DUE ACCOUNTS: AMT reserves the right to withhold open account shipments on any past due account. Invoices are considered past due after thirty (30) days. In the interest of sound business, all orders are subject to approval of the Credit Department.

SHIPPING INSTRUCTIONS: All shipments will be made F.O.B. the factory. Where instructions for shipment do not appear on the order, the shipment will be made according to our best judgment. Full risk of loss (including transportation delays and losses) shall pass to the customer upon delivery of the products to the carrier at the F.O.B. point. When loss or delay occurs, primary responsibility for tracing rests with the customer. When there is LOSS or APPARENT VISIBLE DAMAGE to a shipment, when tendered for delivery, **DO NOT** give the carrier a clear receipt. Note such damage on the carrier's delivery receipt and **HAVE THE DRIVER SIGN THE RECEIPT.**

PRODUCT REVISIONS: AMT reserves the right to discontinue, change or improve its products or any portions thereof without being obligated to provide such a change or improvement for units sold and/or shipped prior to such a change or improvement.

LEAD TIME: Products designated "Quick Ship Product", also referred to as "QSP" will normally be shipped within 24 hours of receipt of a non-cancellable purchase order. Only limited quantities of "QSP" pumps are available.

STANDARD LEAD TIME: Lead time is two weeks for all non "QSP" product. AMT reserves the right to revise lead times as required due to availability of materials and all other causes beyond our control.

VIP SHIPMENT: Select AMT and IPT branded pumps are available for next day shipment for non-QSP (Quick Ship Products) items and subjected to a specific model surcharge per unit noted in the respective price book. Requires calling for availability, confirmation and a non-cancellable purchase order or credit card payment prior to shipment. The expedited shipping charges are an additional cost added separately from the VIP charges per item. AMT reserves the right to revise lead times as required due to availability of materials and all other causes beyond our control. QSP quantities are limited as determined by AMT.

ALL purchase orders must be submitted via hard copy sent to AMT customer service department by fax, EDI or e-mail.

RETURN GOODS POLICY: Goods shall not be returned without a return goods authorization number (RGA) issued by AMT customer service. The RGA number must be listed on the packing list. Only current model and part numbers with a valid date code may be returned (within one year from date of purchase). **A 20% restocking and packaging charge will apply to all returns. All shipping charges must be pre-paid. No exceptions.**

ORDER CHANGES BY CUSTOMER: Orders in process may not be changed except with written consent and may be subject to special charges.

12 Month Limited Warranty

EXTENT AND DURATION OF LIMITED WARRANTY

Coverage: AMT Pump Company (herein "AMT") or IPT Pumps by Gorman-Rupp (herein "IPT") or Gorman-Rupp Industries Division of the The Gorman-Rupp Company, Patterson, or the Gorman-Rupp Company (herein referred to as "G-R Unit") each individually warrants that its products and parts shall be free from defects in material and workmanship for twelve (12) months from the date of purchase by the original end user when installation is made and maintenance is performed in accordance with G-R Unit's recommendations. Wear and tear resulting from use and items normally consumed in use are not covered.

EXCEPTIONS

(A) This Limited Warranty shall not apply to mechanical seals in AMT or IPT pumps and the following products and parts: engines, motors, trade accessories and all other products, components, parts and materials not manufactured by the G-R Units. These items may, however, be covered by the warranties of their respective manufacturers. (B) This warranty does not extend to or apply to any unit which has been repaired or altered at any place other than by a G-R Unit, or by persons not expressly approved by a G-R Unit to make repairs or alterations, nor to any unit the serial number, model number or identification of which has been removed, defaced or altered. (C) This warranty does not extend to any product manufactured by a G-R Unit, which has been subjected to mis-use, neglect, accident, improper installation, or use in violation of instructions furnished by a G-R Unit. (D) Pump Kits: This warranty does not extend to any product sold by a G-R Unit unassembled as a Pump Kit. Pump Kits are warranted against defects in material and workmanship for 60 days from the date of shipment from a G-R Unit. Any Pump Kit parts deemed defective by a G-R Unit will be replaced free of charge within 60 days of shipment. Pump Kits are not returnable for credit.

LIMITATIONS

THE G-R UNITS' SOLE AND EXCLUSIVE WARRANTY WITH RESPECT TO THEIR PRODUCTS AND PARTS IS THIS LIMITED WARRANTY. THIS LIMITED WARRANTY IS IN LIEU OF ALL OTHER EXPRESS AND/OR IMPLIED WARRANTIES, INCLUDING IMPLIED WARRANTIES OF MERCHANTABILITY AND FITNESS FOR PARTICULAR PURPOSE.

EXCLUSIVE REMEDY AND DAMAGES

The sole and exclusive remedy for breach of this Warranty by a G-R Unit and the entire extent of its liability for such breach or for damages arising from the use of the products and parts covered under this Limited Warranty, shall be as follows:

- Repair or Replacement:** If inspection shows that any G-R Unit product or part covered under this Limited Warranty is defective in materials or workmanship, the G-R Unit shall repair or replace the defective or non-conforming product or part without charge, whichever the G-R Unit chooses. You must have properly maintained and used the product or part claimed to be defective in accordance with the maintenance schedule or manual, which comes with the product. No allowance will be made for labor, installation, removal, transportation or other charges incurred by you in connection with such repair or replacement.
- To obtain the above remedy:

- Immediately notify the G-R Unit upon discovery of the claimed defect in materials or workmanship and provide the serial number or date code of the product and/or part(s) or provide the G-R Unit with the invoice or bill of sale referencing the product by no later than the expiration date of the warranty period.
- The G-R Unit will advise whether inspection will be necessary and how whether repair or replacement will be made. If inspection by the G-R Unit is necessary, the pump or defective part must be sent freight pre-paid to the G-R Unit. Return shipment will be F.O.B. the G-R Unit's plant.
- Return Goods Authorization Requirement:** No product will be accepted for return or replacement without the prior written authorization of the G-R Unit. Upon such authorization, and in accordance with instructions from the G-R Unit, the product will be returned to the G-R Unit, shipping charges prepaid by the Buyer.

- Damages:** The G-R Unit's liability for damages for breach of this Limited Warranty shall not exceed the amount of the purchase price of the product or part(s) in respect to which Such damages are claimed. **IN NO EVENT SHALL THE G-R UNITS BE LIABLE FOR INCIDENTAL, CONSEQUENTIAL OR SPECIAL DAMAGES FOR BREACH OF THIS LIMITED WARRANTY.**

Some states do not allow the exclusion or limitation of incidental or consequential damages, so the above limitation or exclusion may not apply to you. This Limited Warranty gives you specific legal rights, and you may also have other rights, which vary from state to state.