

Please read and save this Repair Parts Manual. Read this manual and the General Operating Instructions carefully before attempting to assemble, install, operate or maintain the product described. Protect yourself and others by observing all safety information. The Safety Instructions are contained in the General Operating Instructions. Failure to comply with the safety instructions accompanying this product could result in personal injury and/or property damage! Retain instructions for future reference. AMT reserves the right to discontinue any model or change specifications at any time without incurring any obligation.

©2016 AMT Pump Company, A Subsidiary of The Gorman-Rupp Company, All Rights Reserved.

Periodic maintenance and inspection is required on all pumps to ensure proper operation. Unit must be clear of debris and sediment. Inspect for leaks and loose bolts. Failure to do so voids warranty.

2-Inch Self-Priming Dredging Pump



Refer to pump manual 1808-633-00 (engine-driven) or 1808-635-00 (pedestal mount) for General Operating and Safety Instructions.

DESCRIPTION

These dredging pumps are abrasion-resistant, heavy duty, centrifugal, self-priming (to 20 ft. lift), portable units shipped completely assembled and mounted. Pump is equipped with abrasion resistant high chromium steel, semi-open, solids handling impeller, replaceable volute and wearplate. A built-in check valve assists in priming and a silicon-carbide mechanical shaft seal resists wear and leaking. Simple four bolt casing design for easy cleanout and wear part replacement. Handles liquids from 40° to 160° F (4° to 71° C). This pump is for use with nonflammable liquids compatible with pump component materials.

MAINTENANCE

⚠ WARNING

Make certain that unit is disconnected from power source before attempting to service or remove any components!

CLEANING

This unit has been designed to pump seawater laden with (up to 25%) abrasive particles like sand, stones and shell fragments. It requires some special periodic maintenance to ensure maximum service life.

1. After each use pump must be thoroughly flushed and rinsed with fresh water to remove residual seawater.
2. When not in use, pump should be stored away from damaging effects of seawater environment.

This unit has been designed with a removable volute enabling pump to be cleaned or unclogged easily. Remove casing and volute as described under MECHANICAL SEAL REPLACEMENT. Remove any debris found inside of unit. After each use in a seawater environment, inside and outside of pump must be flushed with fresh water to remove any seawater residue.

MECHANICAL SEAL REPLACEMENT

Refer to figures 1 and 2.

NOTE: Always replace seal seat, (Ref. No. 6), seal head (Ref. No. 7), and shaft sleeve (Ref. No. 8) to ensure proper mating of mechanical seal components!

1. Unthread fasteners (Ref. No. 15) and remove casing (Ref. No. 13), O-ring (Ref. No. 5) and flapper valve (Ref. No. 12) from adapter (Ref. No. 3).
2. Unthread fasteners (Ref. No. 16) and remove volute (Ref. No. 11) from adapter.
3. Unscrew impeller (Ref. No. 10) from shaft. Use a rubber mallet or soft block of wood to loosen impeller. Turn it counterclockwise. Remove impeller shim(s) (Ref. No. 9), shaft sleeve and seal head from shaft. Remove wear-plate (Ref. No. 4) from adapter.

NOTE: To keep shaft from turning on engine driven units, remove shroud from engine and hold flywheel in place.

4. Unthread fasteners (Ref. No. 2 or 32 & 34) and remove adapter from mounting face.
5. Push seal seat from adapter recess with a screwdriver.
6. Clean adapter recess before inserting a new seal seat.
7. Carefully wipe seal face of new seal seat with a clean cloth.
8. Wet outside of rubber portion of seal seat with a light coating of soapy water.
9. Press new seal seat squarely into cavity in adapter. Use finger pressure only to avoid scratching seal seat. (This is a

- lapped surface and must be handled very carefully.)
10. After seal seat is in place, be sure that it is clean and has not been marred.
11. Using a clean cloth, wipe shaft and make certain that it is perfectly clean.
12. Secure adapter on mounting face.

⚠ CAUTION

Tighten fasteners EVENLY to avoid cocking rabbet on mounting face.

13. Apply a light coating of soapy water to inside rubber portion of seal head and slide onto shaft sleeve. Slip shaft sleeve with seal head onto shaft with sealing face toward polished sealing surface of seal seat.

⚠ CAUTION

Do not touch or wipe sealing face of seal head.

14. Replace any impeller shim(s) removed in disassembly.
15. Screw impeller back in place, tightening until it is seated against shims and shaft sleeve.
16. Install wearplate into rabbet in Specifications Information and Repair Parts Manual adapter aligning fastener holes in adapter with clearance holes in wearplate. Remount volute with fasteners.

NOTE: Do not over tighten fasteners. Fasteners should be snug to eliminate play between adapter, wearplate, and volute. Pressure developed from mounting casing to adapter will fix volute and wearplate into position.

17. Refer to section entitled SHIM ADJUSTMENT at this time if shaft sleeve or any other parts listed therein have been replaced.
 18. Inspect position of flapper valve to ensure proper movement and seating.
 19. Position O-ring on volute.
- NOTE:** Always inspect O-ring seal. Replace when cracked or worn. Wet O-ring with soapy water for ease of assembly.
20. Remount casing.

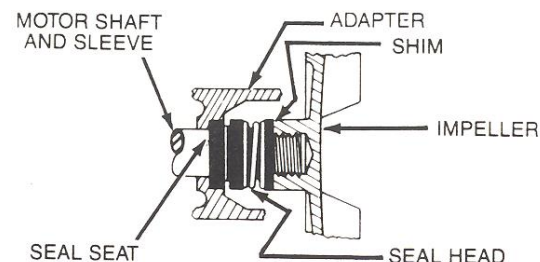

Figure 1 – Mechanical Seal

2-Inch Self-Priming Dredging Pump

SHIM ADJUSTMENT

- When installing a replacement impeller (Ref. No. 10), engine (Ref. No. 1), bearing assembly (Ref. Nos. 33, 35, 36, 38, 39), shaft sleeve (Ref. No. 8), adapter (Ref. No. 3) or volute (Ref. No. 11) it may be necessary to vary number of impeller shims (Ref. No. 9) that will be required. This is easily done by adding one 0.010" shim more than was removed and reassembling pump as described in MECHANICAL SEAL REPLACEMENT section.

NOTE: When adding or removing shims, it is best to proceed with a 0.010" increment each time. Remove spark plug or disconnect and ground spark plug wire, where applicable. While tightening fasteners (Ref. No. 16) turn shaft by hand and feel for shaft seizing. If shaft begins to seize before fasteners are completely tight, disassemble pump and remove one shim and repeat assembly.

- Once having added one shim more than original, ensure that volute and adapter are firmly fitted (check fasteners). When shaft turns freely add shims until it does strike then remove a 0.010" shim. This should allow proper clearance.
- Proper running clearance for impeller should be as close as possible to volute without striking; maximum clearance is 1/32" (0.032").
- Follow above procedure until proper clearance is obtained. This will ensure maximum performance.

IMPELLER, VOLUTE, AND WEARPLATE REPLACEMENT

Impeller (Ref. No. 10), volute (Ref. No. 11) and rear wearplate (Ref. No. 4) are subject to wear by abrasive sand or sediment laden liquids. If badly worn, all these parts can be replaced easily and pump thus restored to full efficiency.

NOTE: When clearance between impeller and volute exceeds 1/16" at face of impeller or 1/8" on outside diameter of impeller, it may be necessary to take corrective action. The increased clearance can cause lengthened priming and decreased capacity to your unit. If performance is satisfactory for your application, it is recommended that no corrective maintenance be performed regardless of what clearances may have developed on your unit. This is because increased clearances in themselves are not generally harmful to your pump. Normally, new pump clearances can be restored by simply shimming behind impeller. (Add shims Ref. No. 9). If impeller is badly worn it is recommended that impeller and volute be replaced. This is usually all that is required since only on unusually abrasive materials will wearplate show deterioration. In these cases, follow instruction below for replacement and refer to Figure 2.

- Disassemble pump for access as described in MECHANICAL SEAL REPLACEMENT, steps 1,2 and 3.
- Replace parts as necessary.

NOTE: When replacing volute, impeller or wearplate, make sure flapper valve (Ref. No. 12) has been installed and is positioned correctly on volute.

NOTE: Before installing new parts, clean all mating surfaces thoroughly.

BEARING HOUSING SERVICE FOR MODEL 316F-99

- Remove front pump assembly as described under Mechanical Seal Replacement (Steps 1, 2 & 3).
- Disassemble bearing housing (Ref. No. 33) from pump adapter (Ref. No. 3) by removing fasteners (Ref. Nos. 31, 32, and 34).
- Remove shaft bearing (Ref. No. 35) and shaft (Ref. No. 36) as an assembly by first removing snap ring (Ref. No. 39). Push shaft bearing assembly out of bearing housing by rapping on threaded end of shaft with a soft mallet or block of wood and a hammer.
- Ball bearings can now be removed from shaft.
- If shaft bearings have been removed from shaft, replace by sliding bearing on shaft to shoulder. Replace shaft bearing assembly by sliding assembly into housing threaded end first. Push shaft bearing assembly completely in by gently tapping on keyway end of shaft with a soft mallet. Replace snap ring.
- Reverse steps 1 thru 3 to reassemble pump.

IMPORTANT: After pump is assembled, it is necessary to rotate pump shaft by hand to check for striking of impeller. If striking or rubbing occurs, adjust impeller shims as required (See Shim Adjustment).



For Repair Parts contact dealer where pump was purchased.

Please provide following information:

- Model Number
- Serial Number (if any)
- Part description and number as shown in parts list

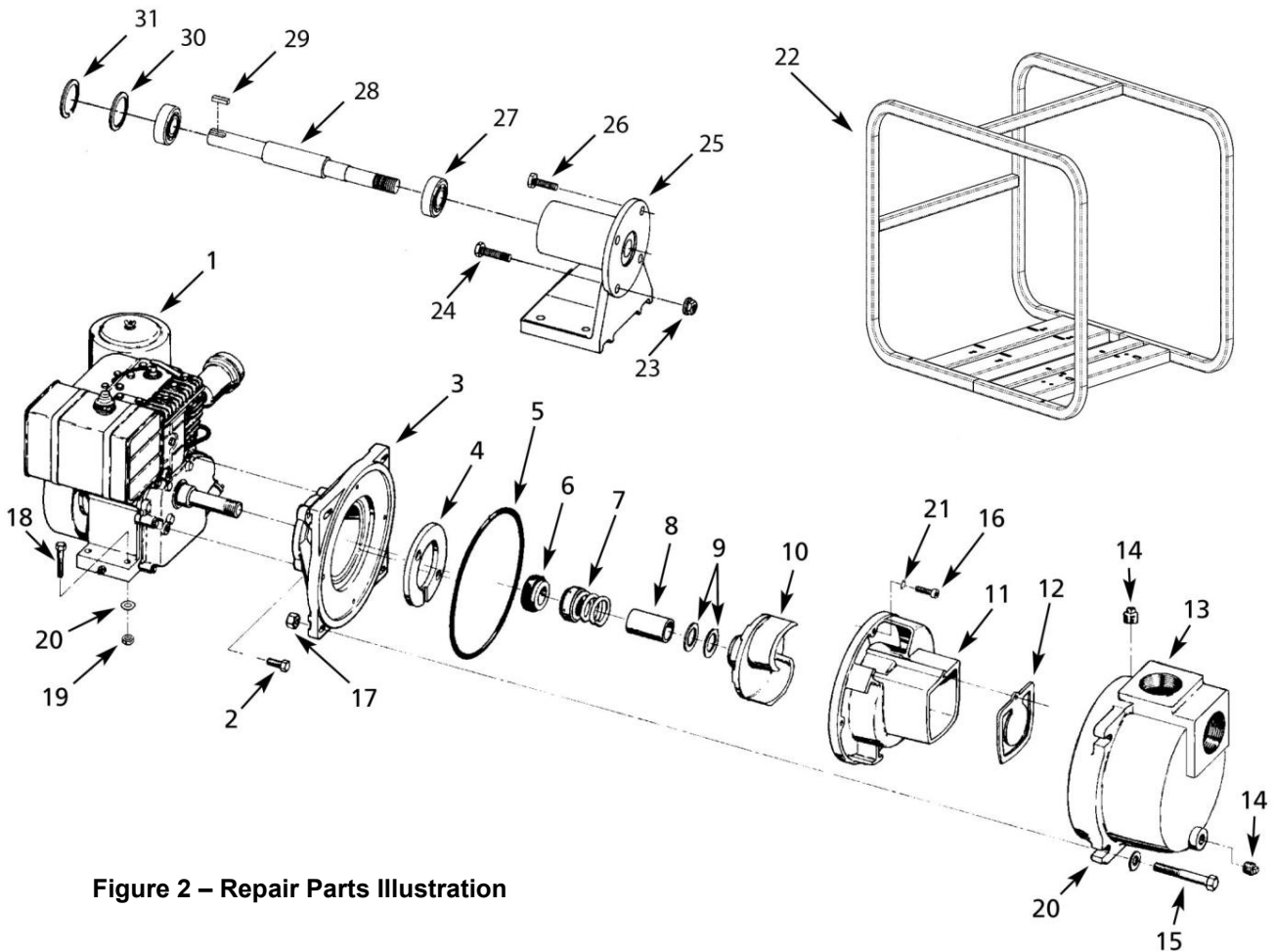

Figure 2 – Repair Parts Illustration



Repair Parts List

| Ref. No. | Description | Part Number for Models: | | | Qty. |
|-------------|--|-------------------------|-------------|-------------|------|
| | | 316F-95 | 316F-D5 | 316F-99 | |
| 1 | Engine | 1639-036-00 | 1630-020-90 | - | 1 |
| 2 | Fastener | * | * | - | 4 |
| 3 | Adapter | 1608-005-03 | 1608-005-03 | 1608-005-03 | 1 |
| 4 | Wear Plate | 316F-061-00 | 316F-061-00 | 316F-061-00 | 1 |
| 5 | O-Ring - Buna-N | 1610-000-00 | 1610-000-00 | 1610-000-00 | 1 |
| 6 & 7 | †Shaft Seal Assembly - Viton & Silicon Carbide | 1641-166-91 | 1641-166-91 | 1641-166-91 | 1 |
| 8 | Shaft Sleeve | 1483-149-00 | 1483-149-00 | 1483-149-00 | 1 |
| 9 | Impeller Shim Package | 1658-000-90 | 1658-000-90 | 1658-000-90 | 1 |
| 10 | Impeller | 2760-010-01 | 2760-010-01 | 2760-010-01 | 1 |
| 11 | Volute | 316F-150-01 | 316F-150-01 | 316F-150-01 | 1 |
| 12 | Flapper Valve - Buna-N | 1609-002-00 | 1609-002-00 | 1609-002-00 | 1 |
| 13 | Casing | 2111-001-02 | 2111-001-02 | 2111-001-02 | 1 |
| 14 | Pipe Plug | * | * | * | 2 |
| 15 | Fastener | * | * | * | 4 |
| 16 | Fastener | * | * | * | 2 |
| 17 | Nut | * | * | * | 4 |
| 18 | Fastener | * | - | * | 4 |
| 19 | Nut | * | - | * | 12 |
| 20 | Washer | * | - | * | 8 |
| 21 | Washer | - | * | - | 2 |
| 22 | Frame Kit | 3120-105-K0 | 3120-105-K0 | - | 1 |
| 22A | Frame Hardware Kit - Gas Engine | 3120-105-93 | - | - | 1 |
| 22A | Frame Hardware Kit - Diesel Engine | - | C400-100-92 | - | 1 |
| 23 | Nut | - | - | * | 4 |
| 24 | Fastener | - | - | * | 2 |
| 25 | Pedestal | - | - | 1695-030-01 | 1 |
| 26 | Fastener | - | - | * | 2 |
| 27 | Bearing | - | - | 1695-031-00 | 2 |
| 28 | Shaft Sleeve | - | - | 1695-001-00 | 1 |
| 29 | Key | - | - | 1517-000-00 | 1 |
| 30 | Bearing Shim Package | - | - | 1696-008-90 | 1 |
| 31 | Snap Ring | - | - | 1695-034-00 | 1 |
| △ | NPT Pipe Nipple Kit | C366-90 | C366-90 | C366-90 | 2 |
| △ | NPT Suction Strainer | C362-90 | C362-90 | C362-90 | 1 |

(*) Standard Hardware Item, Available Locally

(†) Seal assembly available as set only (includes seal head and seat).

(△) Not Shown



NOTES:





AMT Pump Company
(herein "AMT")
400 Spring Street
Royersford, PA 19468
Phone: (610) 948-3800
Fax: (610) 948-5300
www.amtpump.com

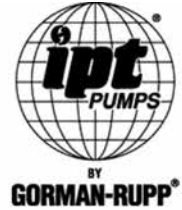

General Information

SALES POLICY: AMT products are sold through our established Distributors. We do not sell direct to the consumer or organization not entitled to trade recognition. Therefore, possession of our catalogs and/or price list(s) does not infer an offer to sell.

MINIMUM ORDER: We appreciate your order, however, all orders are subject to a minimum \$35.00 net invoice charge (excluding freight). This applies to all pump and parts purchase orders.

PRICES: Prices are subject to change without notice. All orders accepted are subject to prices in effect at time of shipment.

PAYMENT TERMS: Terms, upon establishment of credit, are Net 30 days. Past due accounts may be subject to a service charge of 1.5% per month. Domestic or assignable letter of credit is required for all export trade.

PAST DUE ACCOUNTS: AMT reserves the right to withhold open account shipments on any past due account. Invoices are considered past due after thirty (30) days. In the interest of sound business, all orders are subject to approval of the Credit Department.

SHIPPING INSTRUCTIONS: All shipments will be made F.O.B. the factory. Where instructions for shipment do not appear on the order, the shipment will be made according to our best judgment. Full risk of loss (including transportation delays and losses) shall pass to the customer upon delivery of the products to the carrier at the F.O.B. point. When loss or delay occurs, primary responsibility for tracing rests with the customer. When there is LOSS or APPARENT VISIBLE DAMAGE to a shipment, when tendered for delivery, *DO NOT* give the carrier a clear receipt. Note such damage on the carrier's delivery receipt and *HAVE THE DRIVER SIGN THE RECEIPT.*

PRODUCT REVISIONS: AMT reserves the right to discontinue, change or improve its products or any portions thereof without being obligated to provide such a change or improvement for units sold and/or shipped prior to such a change or improvement.

LEAD TIME: Products designated "Quick Ship Product", also referred to as "QSP" will normally be shipped within 24 hours of receipt of a non-cancellable purchase order. Only limited quantities of "QSP" pumps are available.

STANDARD LEAD TIME: Lead time is two weeks for all non "QSP" product. AMT reserves the right to revise lead times as required due to availability of materials and all other causes beyond our control.

VIP SHIPMENT: Select AMT and IPT branded pumps are available for next day shipment for non-QSP (Quick Ship Products) items and subjected to a specific model surcharge per unit noted in the respective price book. Requires calling for availability, confirmation and a non-cancellable purchase order or credit card payment prior to shipment. The expedited shipping charges are an additional cost added separately from the VIP charges per item. AMT reserves the right to revise lead times as required due to availability of materials and all other causes beyond our control. QSP quantities are limited as determined by AMT.

ALL purchase orders must be submitted via hard copy sent to AMT customer service department by fax, EDI or e-mail.

RETURN GOODS POLICY: Goods shall not be returned without a return goods authorization number (RGA) issued by AMT customer service. The RGA number must be listed on the packing list. Only current model and part numbers with a valid date code may be returned (within one year from date of purchase). **A 20% restocking and packaging charge will apply to all returns. All shipping charges must be pre-paid. No exceptions.**

ORDER CHANGES BY CUSTOMER: Orders in process may not be changed except with written consent and may be subject to special charges.

12 Month Limited Warranty

EXTENT AND DURATION OF LIMITED WARRANTY

Coverage: AMT Pump Company (herein "AMT") or IPT Pumps by Gorman-Rupp (herein "IPT") or Gorman-Rupp Industries Division of the The Gorman-Rupp Company, Patterson, or the Gorman-Rupp Company (herein referred to as "G-R Unit") each individually warrants that its products and parts shall be free from defects in material and workmanship for twelve (12) months from the date of purchase by the original end user when installation is made and maintenance is performed in accordance with G-R Unit's recommendations. Wear and tear resulting from use and items normally consumed in use are not covered.

EXCEPTIONS

(A) This Limited Warranty shall not apply to mechanical seals in AMT or IPT pumps and the following products and parts: engines, motors, trade accessories and all other products, components, parts and materials not manufactured by the G-R Units. These items may, however, be covered by the warranties of their respective manufacturers. (B) This warranty does not extend to or apply to any unit which has been repaired or altered at any place other than by a G-R Unit, or by persons not expressly approved by a G-R Unit to make repairs or alterations, nor to any unit the serial number, model number or identification of which has been removed, defaced or altered. (C) This warranty does not extend to any product manufactured by a G-R Unit, which has been subjected to mis-use, neglect, accident, improper installation, or use in violation of instructions furnished by a G-R Unit. (D) Pump Kits: This warranty does not extend to any product sold by a G-R Unit unassembled as a Pump Kit. Pump Kits are warranted against defects in material and workmanship for 60 days from the date of shipment from a G-R Unit. Any Pump Kit parts deemed defective by a G-R Unit will be replaced free of charge within 60 days of shipment. Pump Kits are not returnable for credit.

LIMITATIONS

THE G-R UNITS' SOLE AND EXCLUSIVE WARRANTY WITH RESPECT TO THEIR PRODUCTS AND PARTS IS THIS LIMITED WARRANTY. THIS LIMITED WARRANTY IS IN LIEU OF ALL OTHER EXPRESS AND/OR IMPLIED WARRANTIES, INCLUDING IMPLIED WARRANTIES OF MERCHANTABILITY AND FITNESS FOR PARTICULAR PURPOSE.

EXCLUSIVE REMEDY AND DAMAGES

The sole and exclusive remedy for breach of this Warranty by a G-R Unit and the entire extent of its liability for such breach or for damages arising from the use of the products and parts covered under this Limited Warranty, shall be as follows:

- Repair or Replacement:** If inspection shows that any G-R Unit product or part covered under this Limited Warranty is defective in materials or workmanship, the G-R Unit shall repair or replace the defective or non-conforming product or part without charge, whichever the G-R Unit chooses. You must have properly maintained and used the product or part claimed to be defective in accordance with the maintenance schedule or manual, which comes with the product. No allowance will be made for labor, installation, removal, transportation or other charges incurred by you in connection with such repair or replacement.
- To obtain the above remedy:

- Immediately notify the G-R Unit upon discovery of the claimed defect in materials or workmanship and provide the serial number or date code of the product and/or part(s) or provide the G-R Unit with the invoice or bill of sale referencing the product by no later than the expiration date of the warranty period.
- The G-R Unit will advise whether inspection will be necessary and how whether repair or replacement will be made. If inspection by the G-R Unit is necessary, the pump or defective part must be sent freight pre-paid to the G-R Unit. Return shipment will be F.O.B. the G-R Unit's plant.
- Return Goods Authorization Requirement:** No product will be accepted for return or replacement without the prior written authorization of the G-R Unit. Upon such authorization, and in accordance with instructions from the G-R Unit, the product will be returned to the G-R Unit, shipping charges prepaid by the Buyer.

- Damages:** The G-R Unit's liability for damages for breach of this Limited Warranty shall not exceed the amount of the purchase price of the product or part(s) in respect to which Such damages are claimed. **IN NO EVENT SHALL THE G-R UNITS BE LIABLE FOR INCIDENTAL, CONSEQUENTIAL OR SPECIAL DAMAGES FOR BREACH OF THIS LIMITED WARRANTY.**

Some states do not allow the exclusion or limitation of incidental or consequential damages, so the above limitation or exclusion may not apply to you. This Limited Warranty gives you specific legal rights, and you may also have other rights, which vary from state to state.



A Gorman-Rupp Company

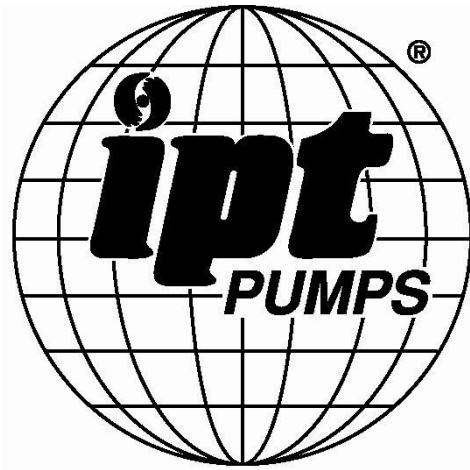

BY
GORMAN-RUPP®

www.amtpump.com

